

PHẦN III

ĐƠN YÊU CẦU CẤP BẰNG ĐỘC QUYỀN KIỂU DÁNG CÔNG NGHIỆP

- (11) **13790**
(21) 3-2008-00589 (28) 01
(54) **GIÀY** (51) **02-04**
(22) 28.04.2008 (43) 25.12.2008
(30) 29/292774 26.10.2007 US
(71) NEW BALANCE ATHLETIC SHOE INC (US)
20 Guest Street, Brighton, Massachusetts 02135, USA
(72) Christopher J. Wawrousek (US)
(74) Công ty TNHH Quốc tế D & N (D&N INTERNATIONAL CO.,LTD.)
(55)



1.1



1.2



1.3



1.4



1.5



1.6



1.7



1.8

- (11) **13791**
(21) 3-2008-00590 (28) 02
(54) **ĐẾ GIÀY** (51) **02-04**
(22) 28.04.2008 (43) 25.12.2008
(30) 29/292773 26.10.2007 US
(71) NEW BALANCE ATHLETIC SHOE INC (US)
20 Guest Street, Brighton, Massachusetts 02135, USA
(72) New Balance Athletic Shoe Inc (US)
(74) Công ty TNHH Quốc tế D & N (D&N INTERNATIONAL CO.,LTD.)
(55)



1.1



1.2



1.3

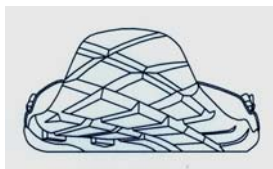

1.4



1.5



1.6



1.7

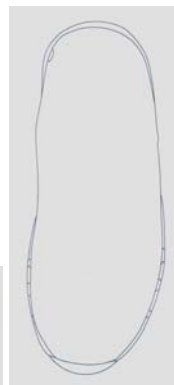

1.8



1.9



2.1

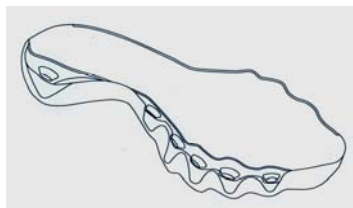

2.2

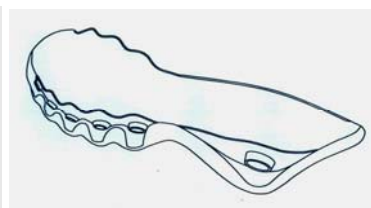

2.3



2.4

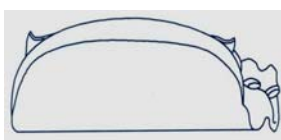

2.5



2.6



2.7

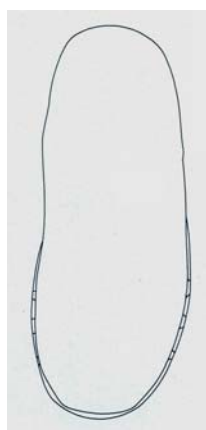

2.8

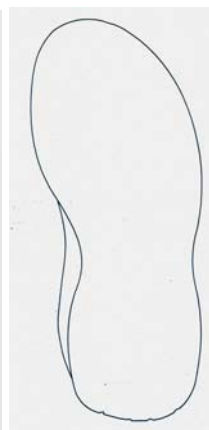

2.9

- (11) **13792**
(21) 3-2008-00591 (28) 01
(54) THANH NHÔM ĐỊNH HÌNH (51) **25-01**
(22) 29.04.2008 (43) 25.12.2008
(71) CÔNG TY TNHH - TM KỸ THUẬT NHÔM HUNG PHÚ THÀNH (VN)
552 Lê Văn Lương, phường Tân Phong, quận 7, TP. Hồ Chí Minh
(72) Đỗ Đức Thành (VN)
(55)

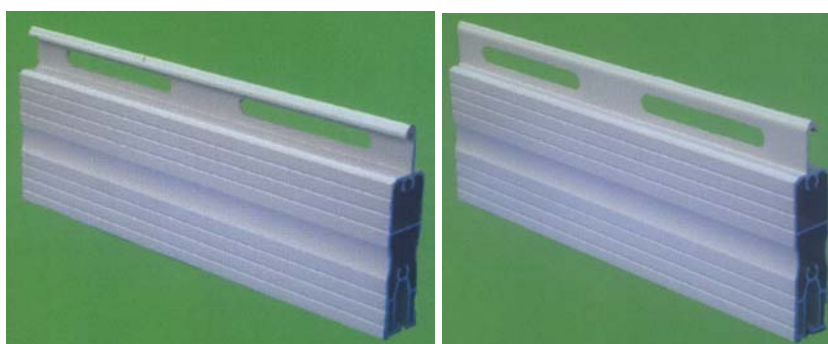

1.1

1.2

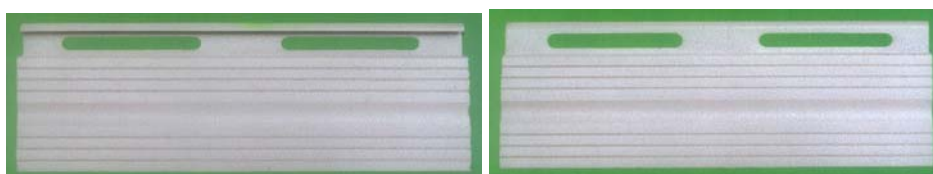

1.3

1.4

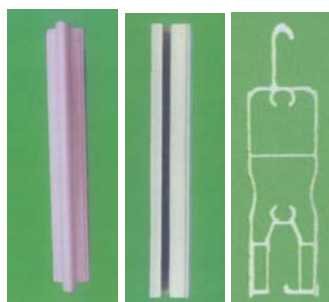

1.5

1.6

1.7

- (11) **13793**
(21) 3-2008-00592 (28) 02
(54) THANH NHÔM ĐỊNH HÌNH (51) **25-01**
(22) 29.04.2008 (43) 25.12.2008
(71) CÔNG TY TNHH - TM KỸ THUẬT NHÔM HUNG PHÚ THÀNH (VN)
552 Lê Văn Lương, phường Tân Phong, quận 7, TP. Hồ Chí Minh
(72) Đỗ Đức Thành (VN)
(55)



1.1

1.2



1.3

1.4

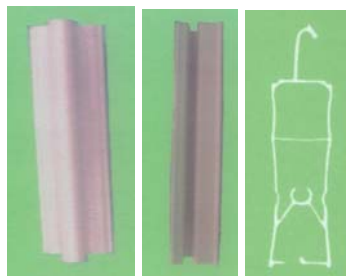

1.5

1.6

1.7

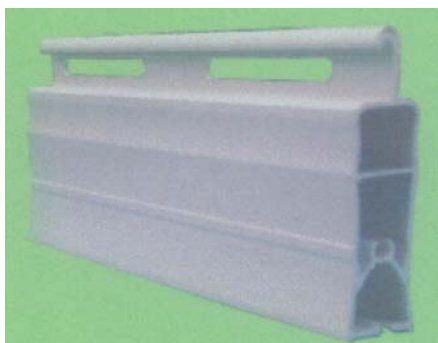

2.1



2.2



2.3



2.4

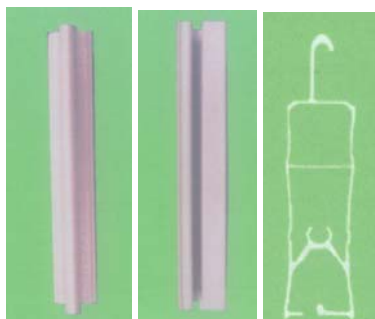

2.5

2.6

2.7

- (11) **13794**
(21) 3-2008-00835 (28) 01
(54) BẾP GA (51) **07-02**
(22) 23.06.2008 (43) 25.12.2008
(71) CÔNG TY TNHH SẢN XUẤT THƯƠNG MẠI UYÊN PHÁT (VN)
D9/262 quốc lộ 50, xã Đa Phước, huyện Bình Chánh, TP. Hồ Chí Minh
(72) Nguyễn Văn Cẩm (VN)
(74) DNTN Dịch vụ thương mại và sở hữu công nghiệp Song Ngọc (I.P.T.S.)
(55)



1.1



1.2

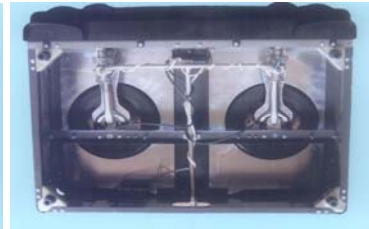

1.3



1.4



1.5



1.6

- (11) **13795**
(21) 3-2008-00911 (28) 01
(54) KHUNG AN TOÀN Ở GHẾ NGỒI (51) **06-01**
CỦA TRẺ EM
(22) 10.07.2008 (43) 25.12.2008
(30) NO 20080014 11.01.2008 NO
(71) PETER OPSVIK AS (NO)
Pilestredet 27H, N-0164 Oslo, Norway
(72) PETER OPSVIK (NO)
(74) Công ty TNHH một thành viên Sở hữu trí tuệ VCCI (VCCI-IP CO.,LTD)
(55)



1.1

1.2

1.3

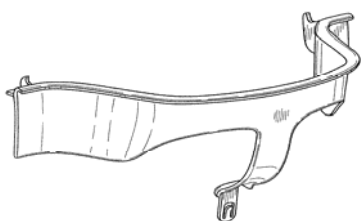

1.4

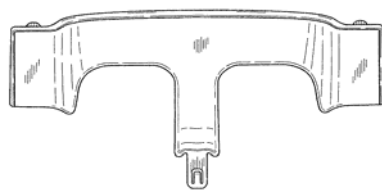

1.5

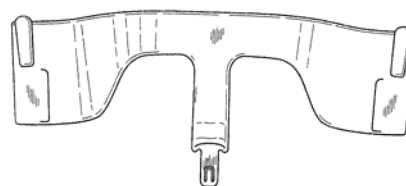

1.6

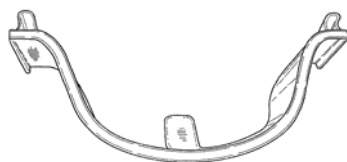

1.7

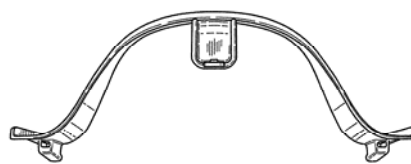

1.8

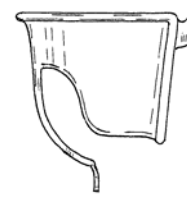

1.9

- (11) **13796**
(21) 3-2008-00929 (28) 01
(54) XE MÁY (51) **12-11**
(22) 14.07.2008 (43) 25.12.2008
(71) CÔNG TY TRÁCH NHIỆM HỮU HẠN SUFAT VIỆT NAM (VN)
Khu công nghiệp Phố Nối B, xã Nghĩa Hiệp, huyện Yên Mỹ, tỉnh Hưng Yên
(72) Phạm Cường (VN)
(55)



1.1



1.2



1.3



1.4



1.5



1.6



1.7



1.8



1.9

- (11) **13797**
(21) 3-2008-00990 (28) 01
(54) CHAI (51) **09-01**
(22) 29.07.2008 (43) 25.12.2008
(71) CÔNG TY TNHH ĐẦU TƯ THƯƠNG MẠI DMP (VN)
Thôn 4, xã Vạn Phúc, huyện Thanh Trì, thành phố Hà Nội
(72) Đỗ Minh Phúc (VN)
(74) Công ty TNHH Trường Xuân (AGELESS CO.,LTD.)
(55)



1.1

1.2

1.3

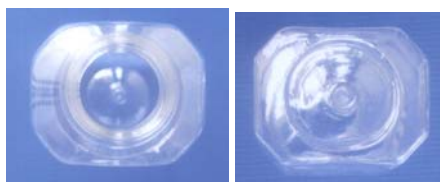

1.4

1.5

- (11) **13798**
(21) 3-2008-01033 (28) 01
(54) CHAI (51) **09-01**
(22) 04.08.2008 (43) 25.12.2008
(30) 000874029-0001 07.02.2008 EM
(71) NOMS DE CODE (FR)
28-32, Avenue Victor Hugo, 75116 Paris, France
(72) Francesco Moretti (IT)
(74) Văn phòng luật sư Phạm và Liên danh (PHAM & ASSOCIATES)
(55)



1.1

1.2

1.3

1.4

1.5

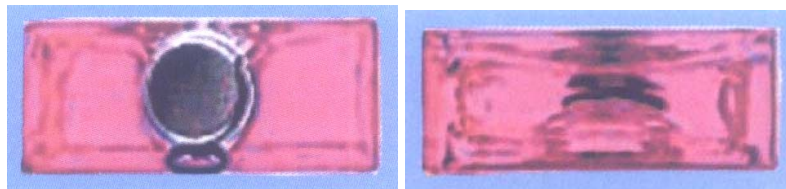

1.6

1.7

- (11) **13799**
(21) 3-2008-01053 (28) 01
(54) XE Ô TÔ (51) **12-08**
(22) 06.08.2008 (43) 25.12.2008
(71) TOYOTA JIDOSHA KABUSHIKI KAISHA (JP)
1, Toyota-cho, Toyota-shi, Aichi-ken 471-8571 Japan
(72) Jiro MATSUEDA (JP)
(74) Công ty TNHH một thành viên Sở hữu trí tuệ VCCI (VCCI-IP CO.,LTD)
(55)



1.1



1.2



1.3



1.4

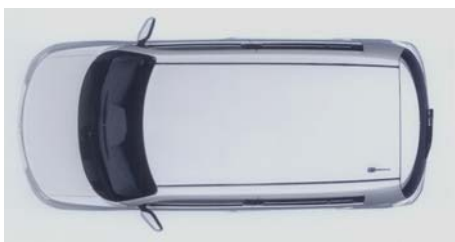

1.5



1.6



1.7

- (11) **13800**
(21) 3-2008-01063 (28) 03
(54) BAO GÓI GIẤY VỆ SINH (51) **09-05**
(22) 08.08.2008 (43) 25.12.2008
(71) CÔNG TY CỔ PHẦN ĐẦU TƯ HÀ THÀNH - NSN (VN)
Số nhà 271, phố Đặng Tiến Đông, tổ 1A, phường Trung Liệt, quận Đống Đa, thành phố Hà Nội
(72) Lê Anh Quân (VN)
(55)



1.1



1.2



2.1



2.2



3.1



3.2

- (11) **13801**
(21) 3-2008-01076
(54) BỘ GÁ KÍNH
(22) 12.08.2008
(71) CÔNG TY TNHH ESP (VN)
Lô điều hành, cụm công nghiệp Nhơn Bình, thành phố Quy Nhơn, tỉnh Bình Định
(72) MARTIN RICHARD BAKER (AU)
(55)
- (28) 01
(51) **08-08**
(43) 25.12.2008

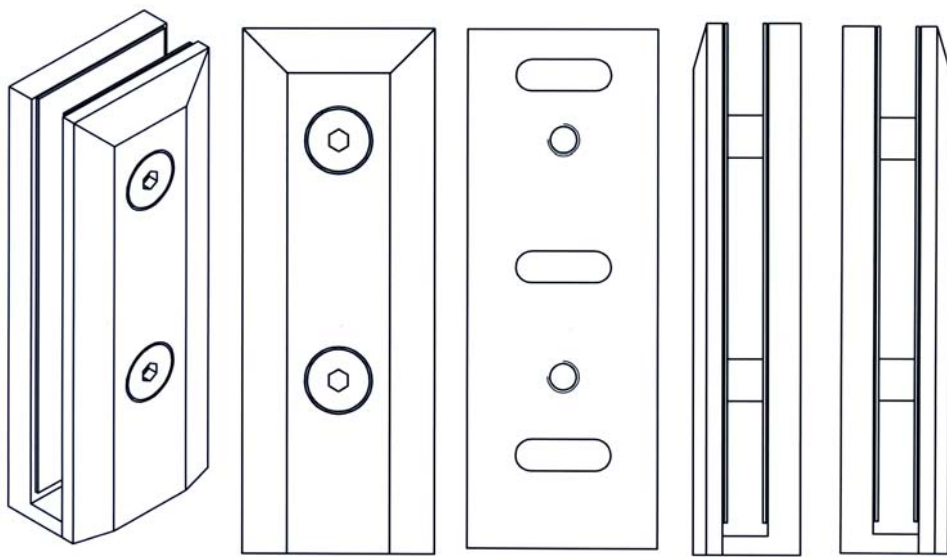

1.1

1.2

1.3

1.4

1.5

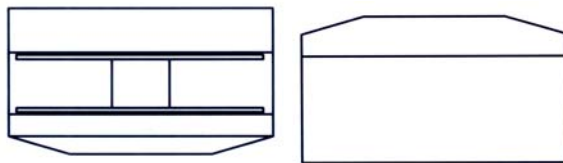

1.6

1.7

- (11) **13802**
(21) 3-2008-01077
(54) BẢN LỀ LÒ XO
(22) 12.08.2008
(71) CÔNG TY TNHH ESP (VN)
Lô điều hành, cụm công nghiệp Nhơn Bình, thành phố Quy Nhơn, tỉnh Bình Định
(72) MARTIN RICHARD BAKER (AU)
(55)
- (28) 01
(51) **08-06**
(43) 25.12.2008

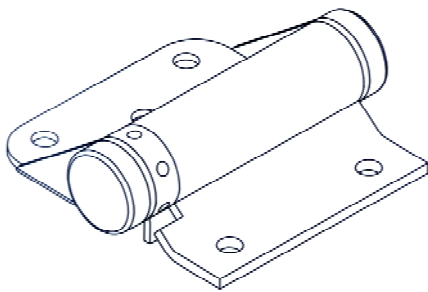

1.1

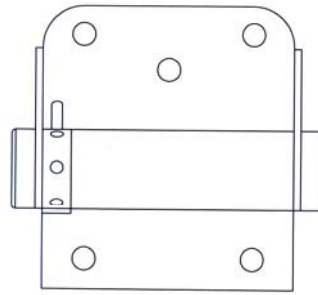

1.2

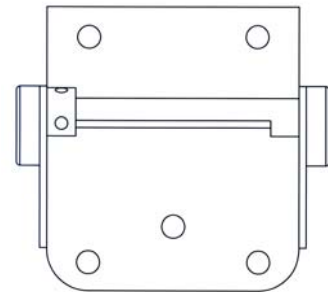

1.3

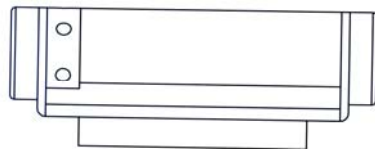

1.4

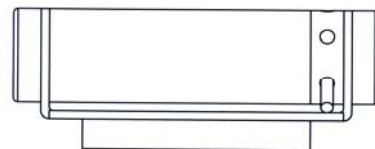

1.5

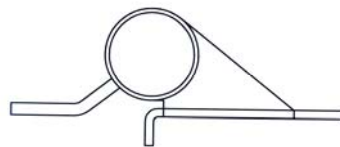

1.6

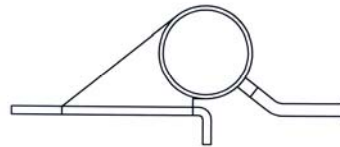

1.7

(11) **13803**

(21) 3-2008-01078

(54) KHÓA NAM CHÂM

(22) 12.08.2008

(71) CÔNG TY TNHH ESP (VN)

Lô điều hành, cụm công nghiệp Nhơn Bình, thành phố Quy Nhơn, tỉnh Bình Định

(72) MARTIN RICHARD BAKER (AU)

(55)

(28) 01

(51) **08-07**

(43) 25.12.2008

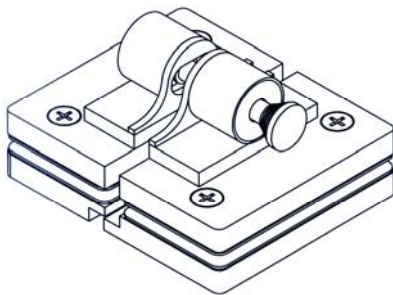

1.1

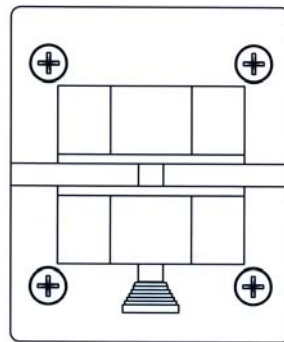

1.2

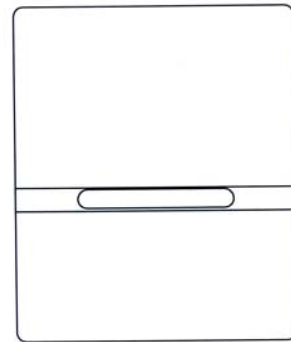

1.3

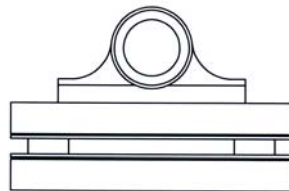

1.4

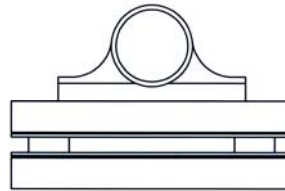

1.5

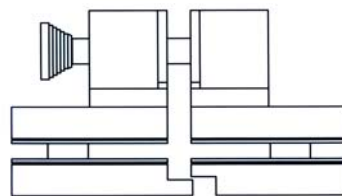

1.6

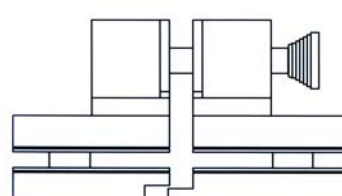

1.7

- (11) **13804**
(21) 3-2008-01079 (28) 01
(54) KHÓA NAM CHÂM ĐƠN (51) **08-07**
(22) 12.08.2008 (43) 25.12.2008
(71) CÔNG TY TNHH ESP (VN)
Lô điều hành, cụm công nghiệp Nhơn Bình, thành phố Quy Nhơn, tỉnh Bình Định
(72) MARTIN RICHARD BAKER (AU)
(55)

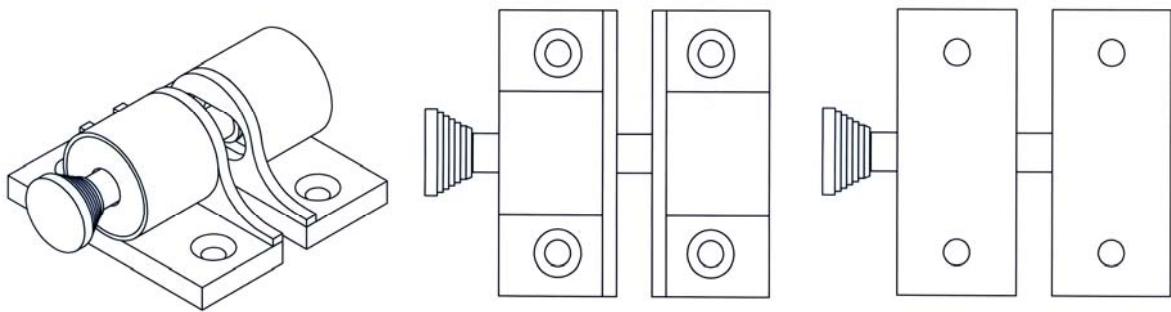

1.1

1.2

1.3

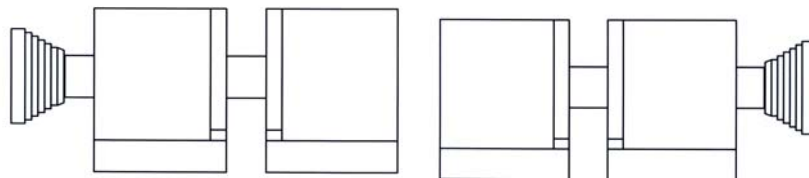

1.4

1.5

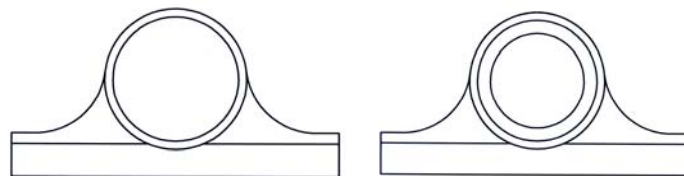

1.6

1.7

- (11) **13805**
(21) 3-2008-01080
(54) KHÓA NAM CHÂM TRÒN
(22) 12.08.2008
(71) CÔNG TY TNHH ESP (VN)
Lô điều hành, cụm công nghiệp Nhơn Bình, thành phố Quy Nhơn, tỉnh Bình Định
(72) MARTIN RICHARD BAKER (AU)
(55)
- (28) 01
(51) **08-07**
(43) 25.12.2008

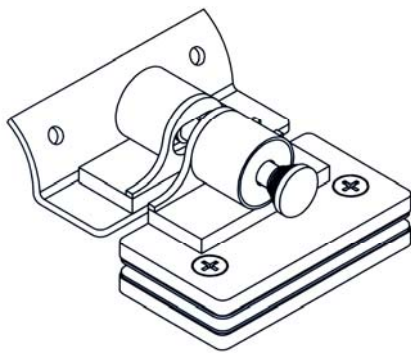

1.1

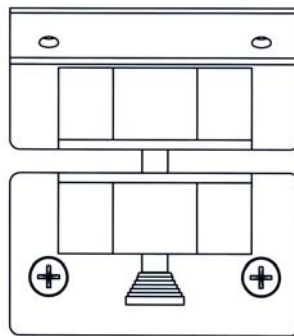

1.2

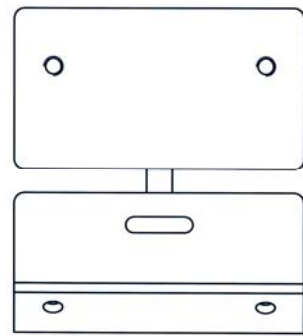

1.3

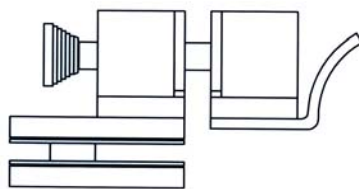

1.4

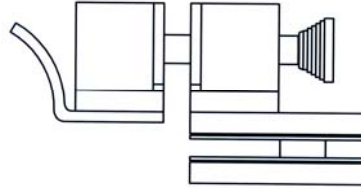

1.5

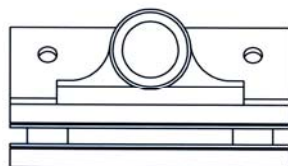

1.6

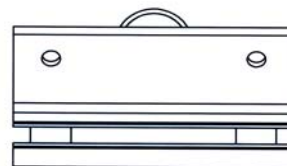

1.7

- (11) **13806**
(21) 3-2008-01081
(54) KHÓA NAM CHÂM
(22) 12.08.2008
(71) CÔNG TY TNHH ESP (VN)
Lô điều hành, cụm công nghiệp Nhơn Bình, thành phố Quy Nhơn, tỉnh Bình Định
(72) MARTIN RICHARD BAKER (AU)
(55)
- (28) 01
(51) **08-07**
(43) 25.12.2008

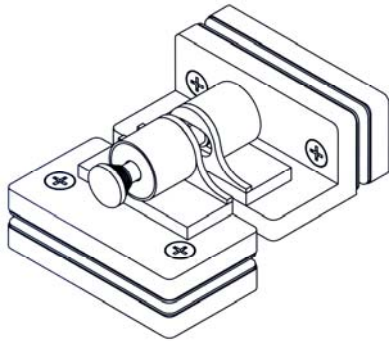

1.1

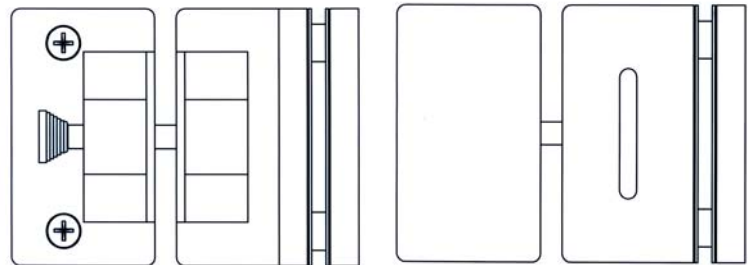

1.2

1.3

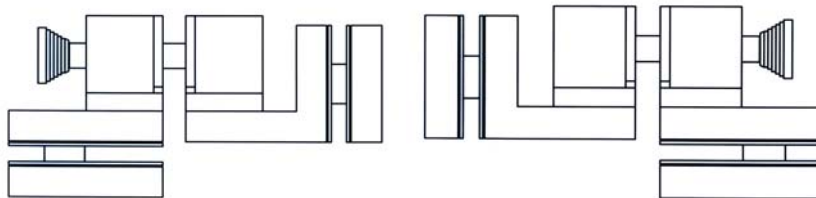

1.4

1.5

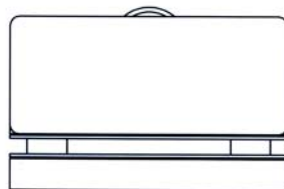

1.6

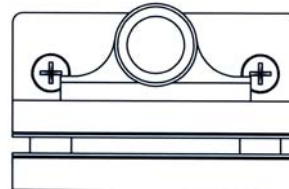

1.7

- (11) **13807**
(21) 3-2008-01082 (28) 01
(54) GIÁ NÂNG XE MÁY (51) **12-05**
(22) 12.08.2008 (43) 25.12.2008
(71) CÔNG TY TNHH ESP (VN)
Lô điều hành, cụm công nghiệp Nhơn Bình, thành phố Quy Nhơn, tỉnh Bình Định
(72) MARTIN RICHARD BAKER (AU)
(55)

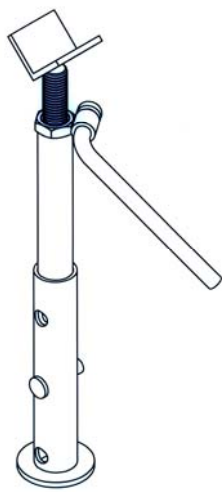

1.1

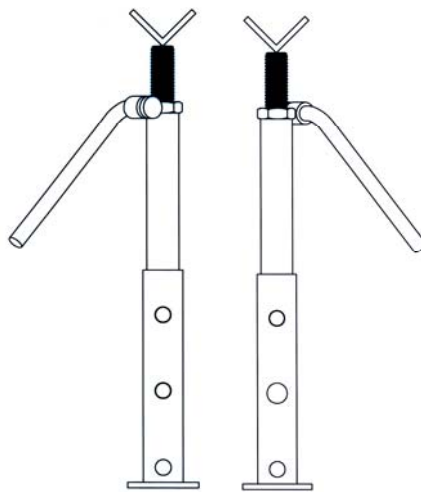

1.2

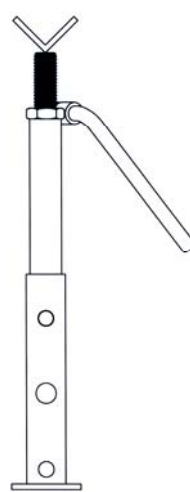

1.3

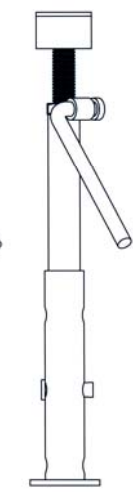

1.4

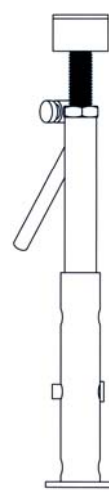

1.5

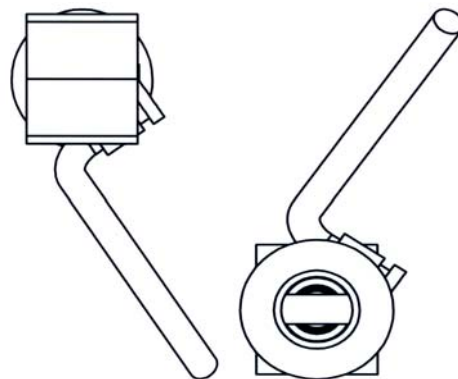

1.6

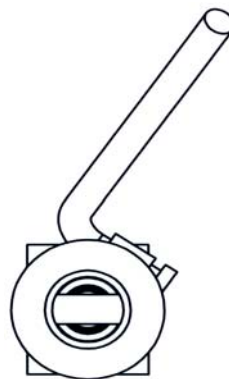

1.7

(11) **13808**

(21) 3-2008-01083

(54) **BỘ GÁ KÍNH**

(22) 12.08.2008

(71) **CÔNG TY TNHH ESP (VN)**

Lô điều hành, cụm công nghiệp Nhơn Bình, thành phố Quy Nhơn, tỉnh Bình Định

(72) **MARTIN RICHARD BAKER (AU)**

(55)

(28) 01

(51) **08-08**

(43) 25.12.2008

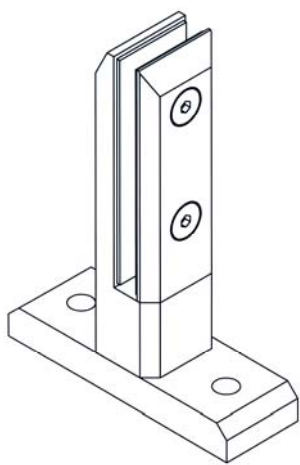

1.1

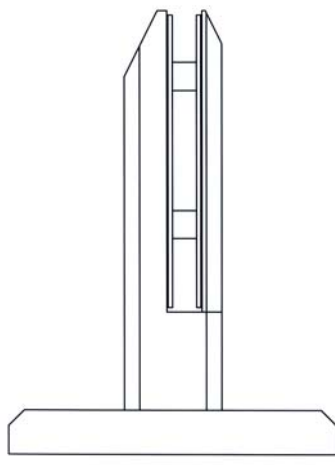

1.2

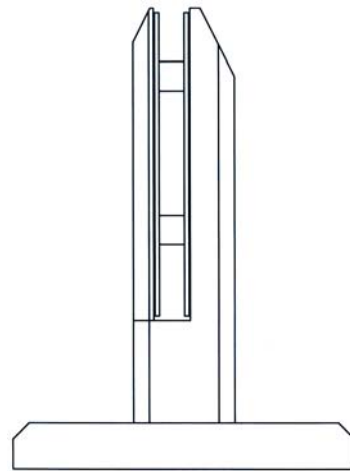

1.3

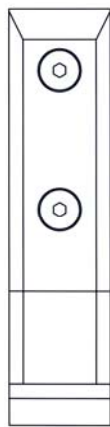

1.4

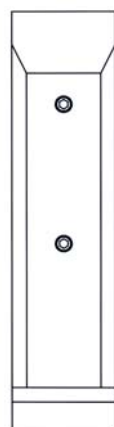

1.5

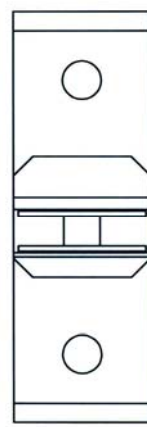

1.6

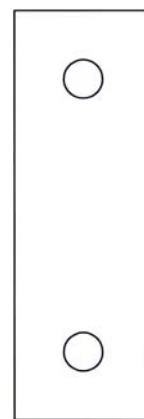

1.7

- (11) **13809**
(21) 3-2008-01084
(54) BẢN LỀ NGUYÊN KHUNG
(22) 12.08.2008
(71) CÔNG TY TNHH ESP (VN)
Lô điều hành, cụm công nghiệp Nhơn Bình, thành phố Quy Nhơn, tỉnh Bình Định
(72) MARTIN RICHARD BAKER (AU)
(55)
- (28) 01
(51) **08-06**
(43) 25.12.2008

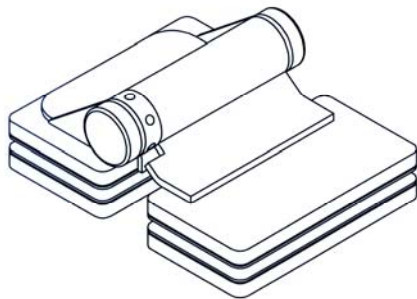

1.1

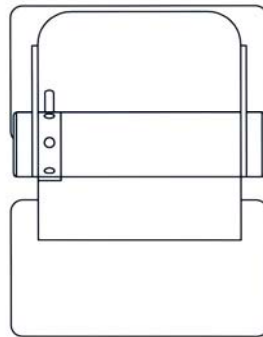

1.2

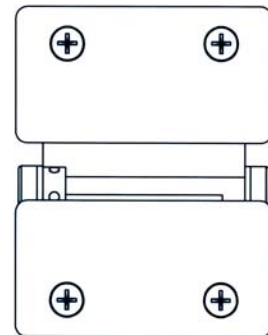

1.3

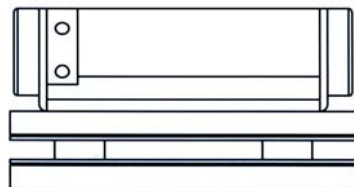

1.4

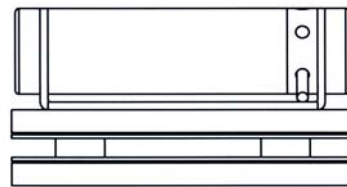

1.5



1.6

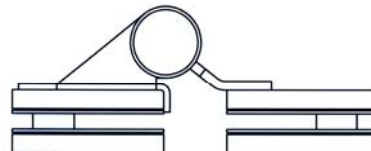

1.7

- (11) **13810**
(21) 3-2008-01085
(54) BẢN LỀ BÁN KHUNG
(22) 12.08.2008
(71) CÔNG TY TNHH ESP (VN)
Lô điều hành, cụm công nghiệp Nhơn Bình, thành phố Quy Nhơn, tỉnh Bình Định
(72) MARTIN RICHARD BAKER (AU)
(55)
- (28) 01
(51) **08-06**
(43) 25.12.2008

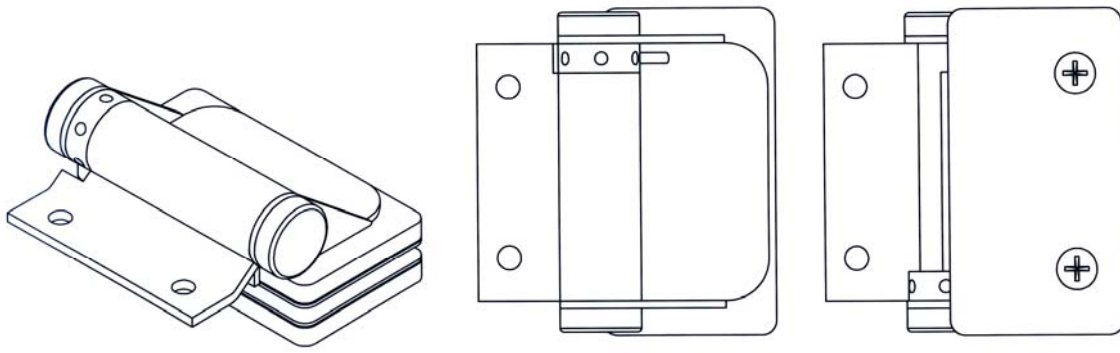

1.1

1.2

1.3

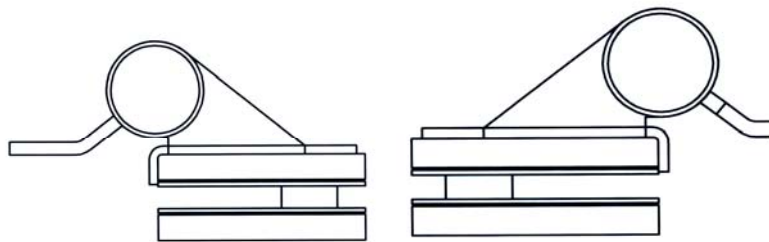

1.4

1.5

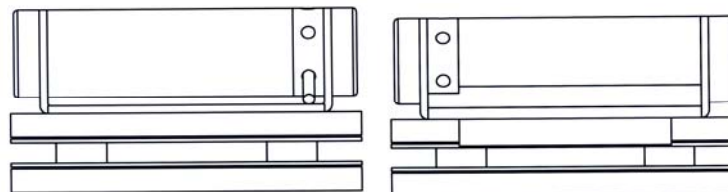

1.6

1.7

- (11) **13811**
(21) 3-2008-01086 (28) 01
(54) KHÓA NAM CHÂM VUÔNG (51) **08-07**
(22) 12.08.2008 (43) 25.12.2008
(71) CÔNG TY TNHH ESP (VN)
Lô điều hành, cụm công nghiệp Nhơn Bình, thành phố Quy Nhơn, tỉnh Bình Định
(72) MARTIN RICHARD BAKER (AU)
(55)

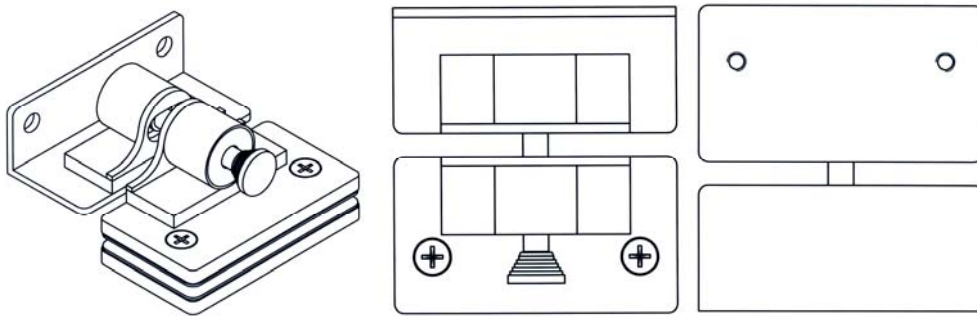

1.1

1.2

1.3

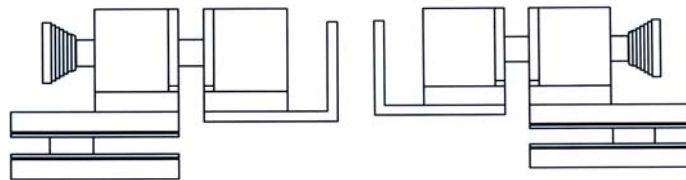

1.4

1.5

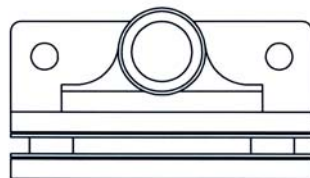

1.6

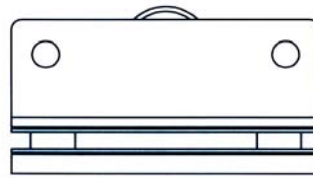

1.7

- (11) **13812**
(21) 3-2008-01087
(54) BỘ GÁ KÍNH
(22) 12.08.2008
(71) CÔNG TY TNHH ESP (VN)
Lô điều hành, cụm công nghiệp Nhơn Bình, thành phố Quy Nhơn, tỉnh Bình Định
(72) MARTIN RICHARD BAKER (AU)
(55)
- (28) 01
(51) **08-08**
(43) 25.12.2008

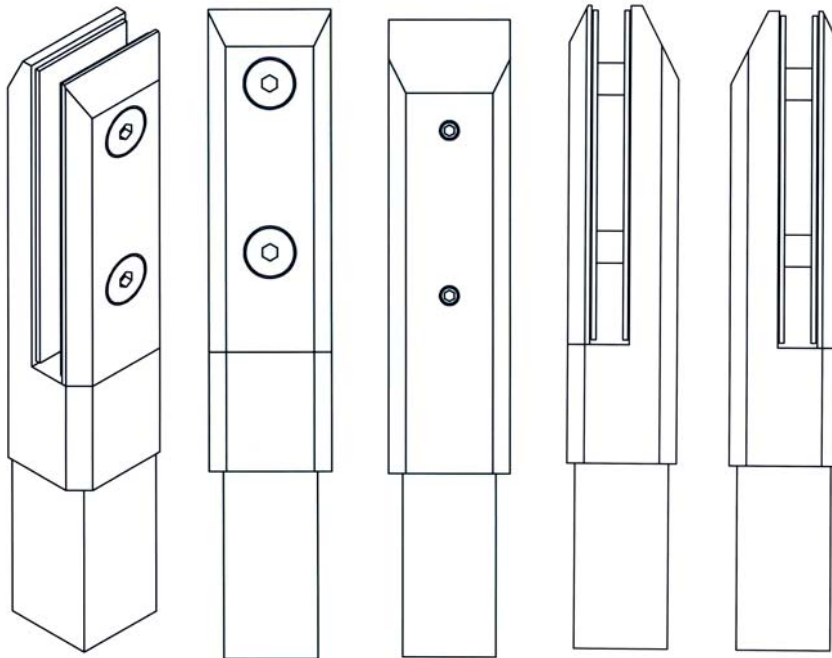

1.1

1.2

1.3

1.4

1.5

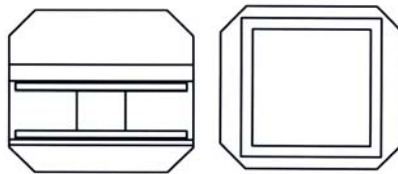

1.6

1.7

- (11) **13813**
(21) 3-2008-01091 (28) 01
(54) VAN KÍN KHÍ (51) **15-09**
(22) 13.08.2008 (43) 25.12.2008
(71) CÔNG TY CỔ PHẦN LILAMA 69-3 (VN)
Số 515 đường Điện Biên Phủ, thành phố Hải Dương, tỉnh Hải Dương
(72) Vũ Văn Hậu (VN)
(74) Công ty TNHH Sở hữu trí tuệ HA VIP (HAVIP CO., LTD.)
(55)

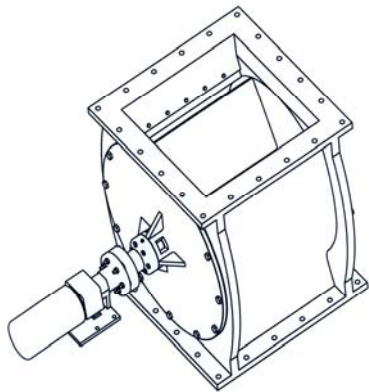

1.1

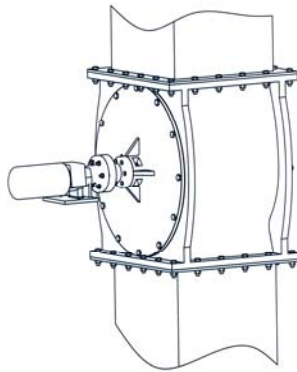

1.2

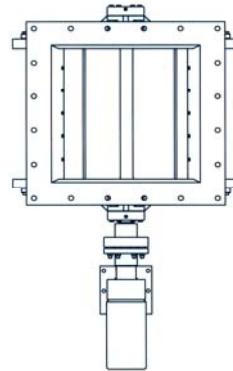

1.3

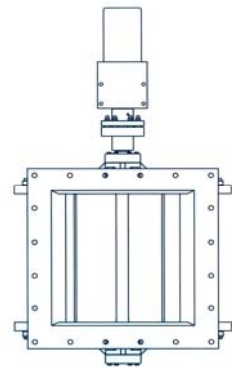

1.4

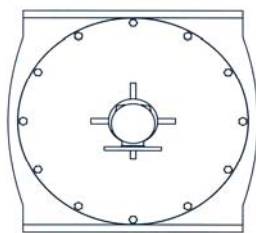

1.5

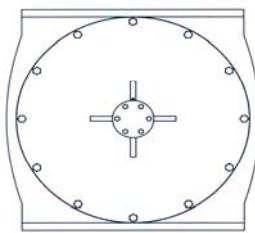

1.6

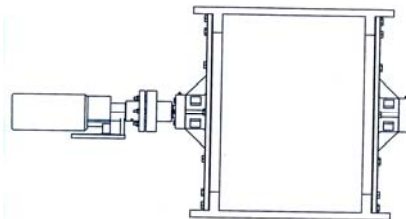

1.7

- (11) **13814**
(21) 3-2008-01092
(54) VAN PHÒNG NỔ
(22) 13.08.2008
(71) CÔNG TY CỔ PHẦN LILAMA 69-3 (VN)
Số 515 đường Điện Biên Phủ, thành phố Hải Dương, tỉnh Hải Dương
(72) Vũ Văn Hậu (VN)
(74) Công ty TNHH Sở hữu trí tuệ HA VIP (HAVIP CO., LTD.)
(55)
- (28) 01
(51) **15-09**
(43) 25.12.2008

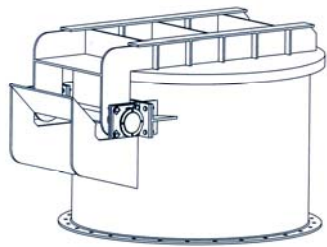

1.1

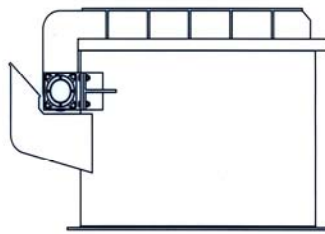

1.2

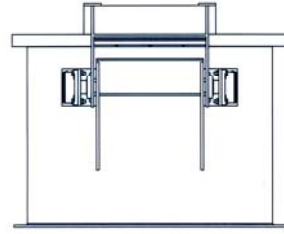

1.3

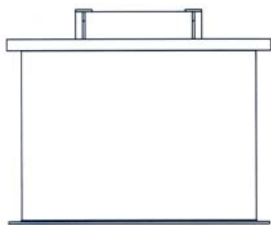

1.4

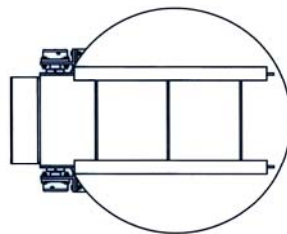

1.5

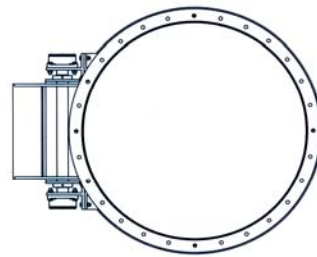

1.6

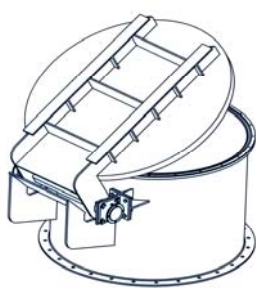

1.7

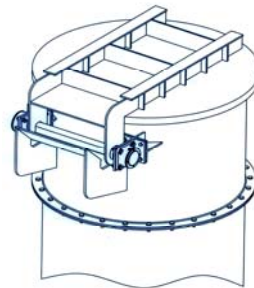

1.8

CÔNG BÁO SỞ HỮU CÔNG NGHIỆP SỐ 249 TẬP A (12.2008)

- (11) **13815**
(21) 3-2008-01096 (28) 01
(54) HỘP NƯỚC SÂM (51) **09-03**
(22) 13.08.2008 (43) 25.12.2008
(71) CÔNG TY TNHH HOÀNG HƯƠNG (VN)
Số 6, ngõ 111 Láng Hạ, quận Đống Đa, thành phố Hà Nội
(72) Đinh Thị Chì (VN)
(74) Công ty TNHH Sở hữu trí tuệ WINCO (WINCO CO., LTD.)
(55)



1.1

1.2

1.3

1.4



1.5



1.6



1.7

- (11) **13816**
(21) 3-2008-01110 (28) 01
(54) THÙNG (51) **09-02**
(22) 14.08.2008 (43) 25.12.2008
(71) CÔNG TY TRÁCH NHIỆM HỮU HẠN NHỰA CƠ KHÍ VÀ THƯƠNG MẠI CHẤN
THỤẬN THÀNH (VN)
93A Lý Chiêu Hoàng, phường 10, quận 6, TP. Hồ Chí Minh
(72) Trần Em (VN)
(74) Công ty TNHH Sở hữu trí tuệ Thảo Thọ Quyển (INVENCO)
(55)



1.1

1.2

1.3

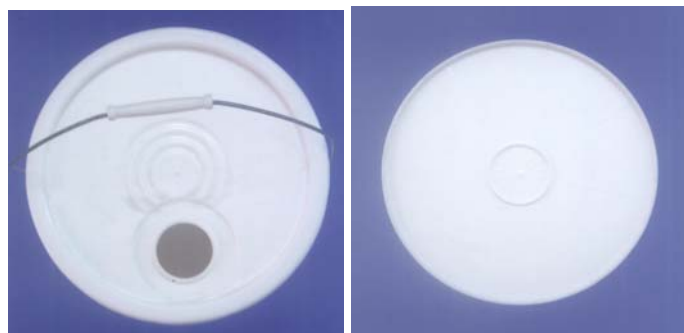

1.4

1.5

(11) **13817**

(21) 3-2008-01115

(28) 01

(54) TẮM ỐP MẶT TRƯỚC THÙNG (51) **14-01**

LOA

(22) 15.08.2008

(43) 25.12.2008

(71) NGÔ MẠNH HÙNG (VN)

76/32 Lê Văn Phan, phường Phú Thọ Hòa, quận Tân Phú, TP. Hồ Chí Minh

(72) Ngô Mạnh Hùng (VN)

(74) Văn phòng luật sư Phạm và Liên danh (PHAM & ASSOCIATES)

(55)

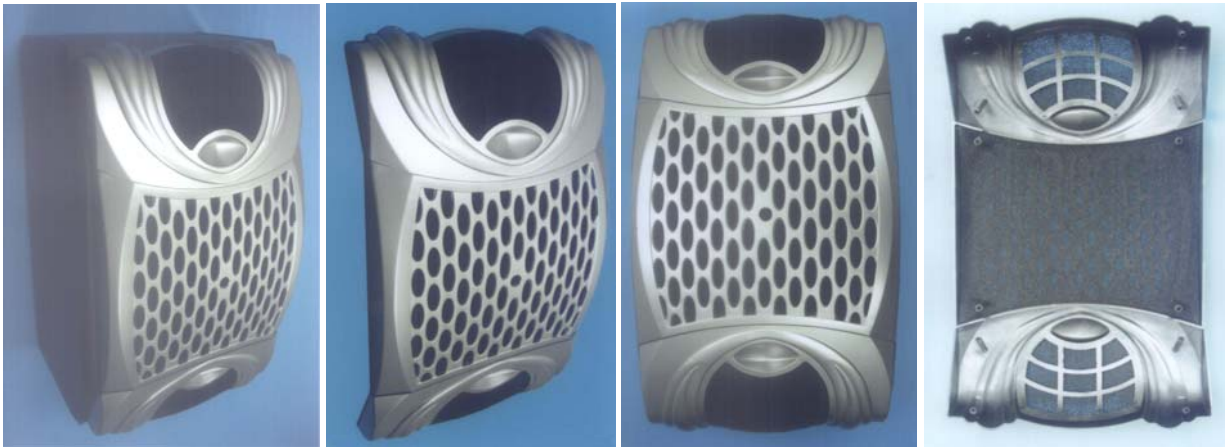

1.1

1.2

1.3

1.4

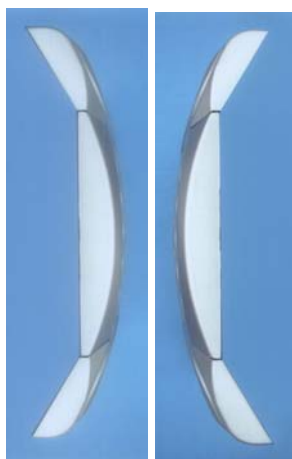

1.5

1.6



1.7

1.8

- (11) **13818**
(21) 3-2008-01135 (28) 01
(54) CHAI CÓ ỐNG BƠM (51) **09-01**
(22) 18.08.2008 (43) 25.12.2008
(30) 4006617 18.02.2008 GB
(71) UNILEVER N.V. (NL)
Weena 455, 3013 AL Rotterdam, Netherlands
(72) Luis Ernesto RIBADENEIRA MEJIA (CO), Adrian Barclay CAROEN (GB)
(74) Công ty TNHH Trần Hữu Nam và Đồng sự (TRAN H.N & ASS.)
(55)



1.1

1.2

1.3

1.4

1.5

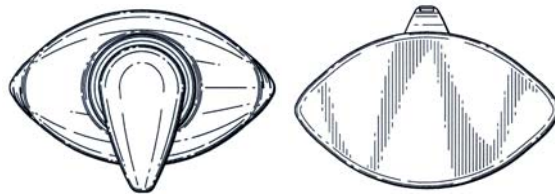

1.6

1.7

- (11) **13819**
(21) 3-2008-01154
(54) CHAI
(22) 22.08.2008
(71) CÔNG TY CỔ PHẦN HÀ NỘI - HUNG YÊN (VN)
Đường 206 Lạc Đạo, Văn Lâm, tỉnh Hưng Yên
(72) Bùi Anh Tuấn (VN)
(55)
(28) 01
(51) **09-01**
(43) 25.12.2008



1.1

1.2

1.3

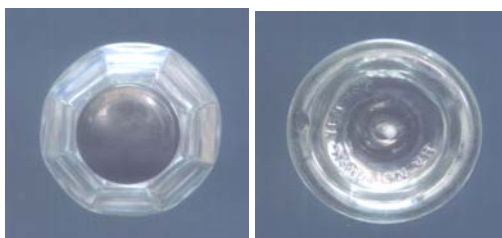

1.4

1.5

- (11) **13820**
(21) 3-2008-01155
(54) MÁY BAY
(22) 22.08.2008
(71) AIR BUSAN CO., LTD. (KR)
6 FL., 853-1 Beomcheon-dong, Busanjin-gu, Busan, Republic of Korea
(72) HWANG, Joon Yup (KR)
(74) Công ty TNHH Quốc tế D & N (D&N INTERNATIONAL CO.,LTD.)
(55)
- (28) 01
(51) **12-07**
(43) 25.12.2008



1.1



1.2



1.3



1.4



1.5



1.6



1.7

- (11) **13821**
(21) 3-2008-01157
(54) CHAI
(22) 25.08.2008
(71) CÔNG TY CỔ PHẦN HÀ NỘI - HUNG YÊN (VN)
Đường 206 Lạc Đạo, Văn Lâm, tỉnh Hưng Yên
(72) Bùi Anh Tuấn (VN)
(55)
(28) 01
(51) **09-01**
(43) 25.12.2008



1.1

1.2

1.3

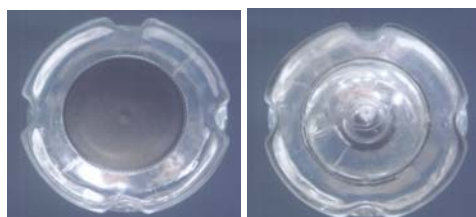

1.4

1.5

- (11) **13822**
(21) 3-2008-01159 (28) 01
(54) THIẾT BỊ UỐN MÉP GIẤY (51) **18-04**
(22) 25.08.2008 (43) 25.12.2008
(30) 29/304091 25.02.2008 US
(71) UNITED STATES GYPSUM COMPANY (US)
550 West Adams Street, Chicago, Illinois 60661-3676, United States of America
(72) Aaron Charles Rosso (US), Matthew Earle Myers (US), Amar Arvind Patel (US), Joseph
Z. Wascow (US), Stephen M. Oshgan (US), Brian A. Retzke (US)
(74) Văn phòng luật sư Phạm và Liên danh (PHAM & ASSOCIATES)
(55)

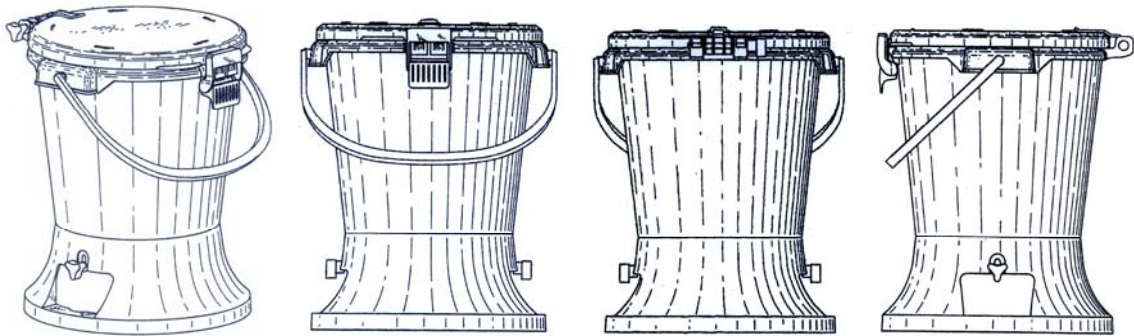

1.1

1.2

1.3

1.4

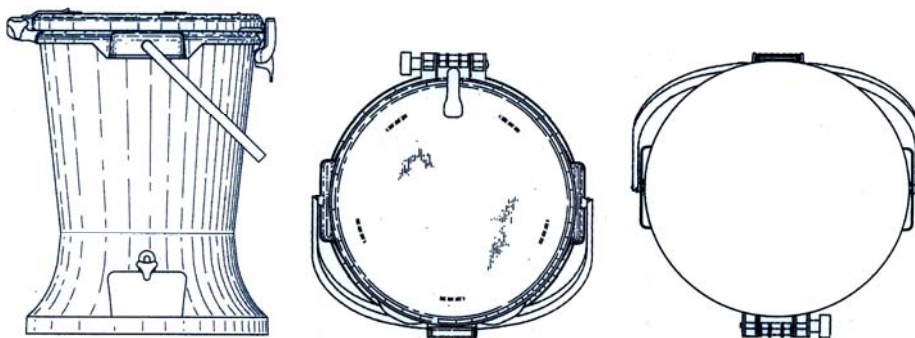

1.5

1.6

1.7

- (11) **13823**
(21) 3-2008-01165 (28) 01
(54) CHAI (51) **09-01**
(22) 25.08.2008 (43) 25.12.2008
(71) CÔNG TY CỔ PHẦN HOÁ MỸ PHẨM CHÂU ÂU (VN)
XN7, khu công nghiệp Bắc Thường Tín, xã Văn Bình, huyện Thường Tín, thành phố Hà Nội
(72) Trần Minh Khánh (VN)
(55)



1.1

1.2

1.3

1.4

1.5



1.6

1.7

- (11) **13824**
(21) 3-2008-01167
(54) **NHÃN SẢN PHẨM**
(22) 26.08.2008
(71) **CÔNG TY TNHH CÔNG NGHỆ THỰC PHẨM CHÂU Á (VN)**
Lô G2, khu công nghiệp Tiên Sơn, tỉnh Bắc Ninh
(72) Lê Thị Hoàng Oanh (VN)
(74) Văn phòng luật sư Phạm và Liên danh (PHAM & ASSOCIATES)
(55)
- (28) 01
(51) **19-08**
(43) 25.12.2008

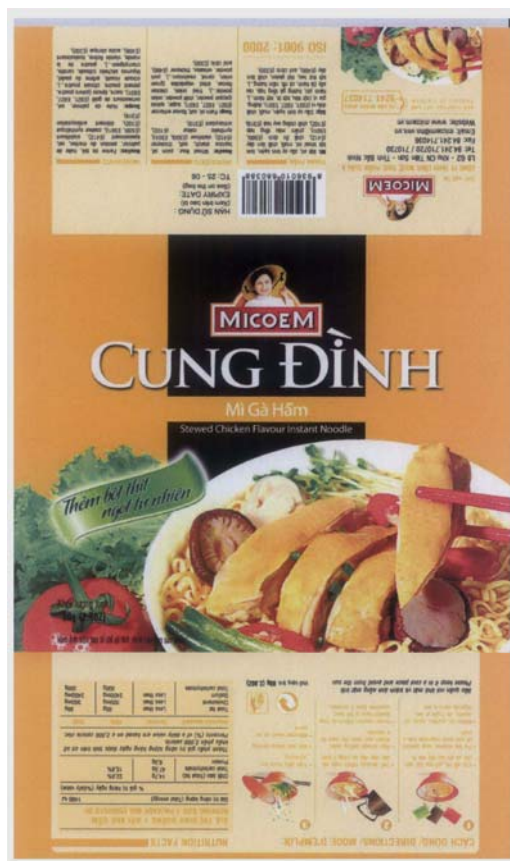

- (11) **13825**
(21) 3-2008-01176 (28) 01
(54) MÁY ĐIỆN THOẠI DI ĐỘNG (51) **14-03**
(22) 27.08.2008 (43) 25.12.2008
(71) TRẦN VĂN ĐỈNH (VN)
98 Nguyễn Thái Học, phường Tân Thành, quận Tân Phú, TP. Hồ Chí Minh
(72) Trần Văn Đỉnh (VN)
(74) Công ty TNHH Sở hữu trí tuệ WINCO (WINCO CO., LTD.)
(55)



1.1

1.2

1.3

1.4

1.5

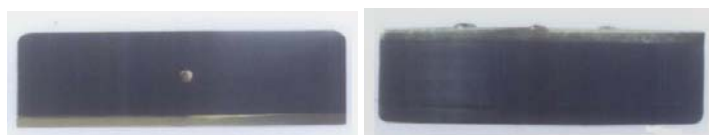

1.6

1.7

- (11) **13826**
(21) 3-2008-01187 (28) 01
(54) HỘP ĐỰNG (51) **09-03**
(22) 28.08.2008 (43) 25.12.2008
(30) 4006725 28.02.2008 GB
(71) UNILEVER N.V. (NL)
Weena 455, 3013 AL Rotterdam, Netherlands
(72) Patrice SANT' ANA CACERES (BR), João Carlos da SILVA (BR), Jociane TESSER (BR), Anderson UTEMBERGUE (BR)
(74) Công ty TNHH Trần Hữu Nam và Đồng sự (TRAN H.N & ASS.)
(55)

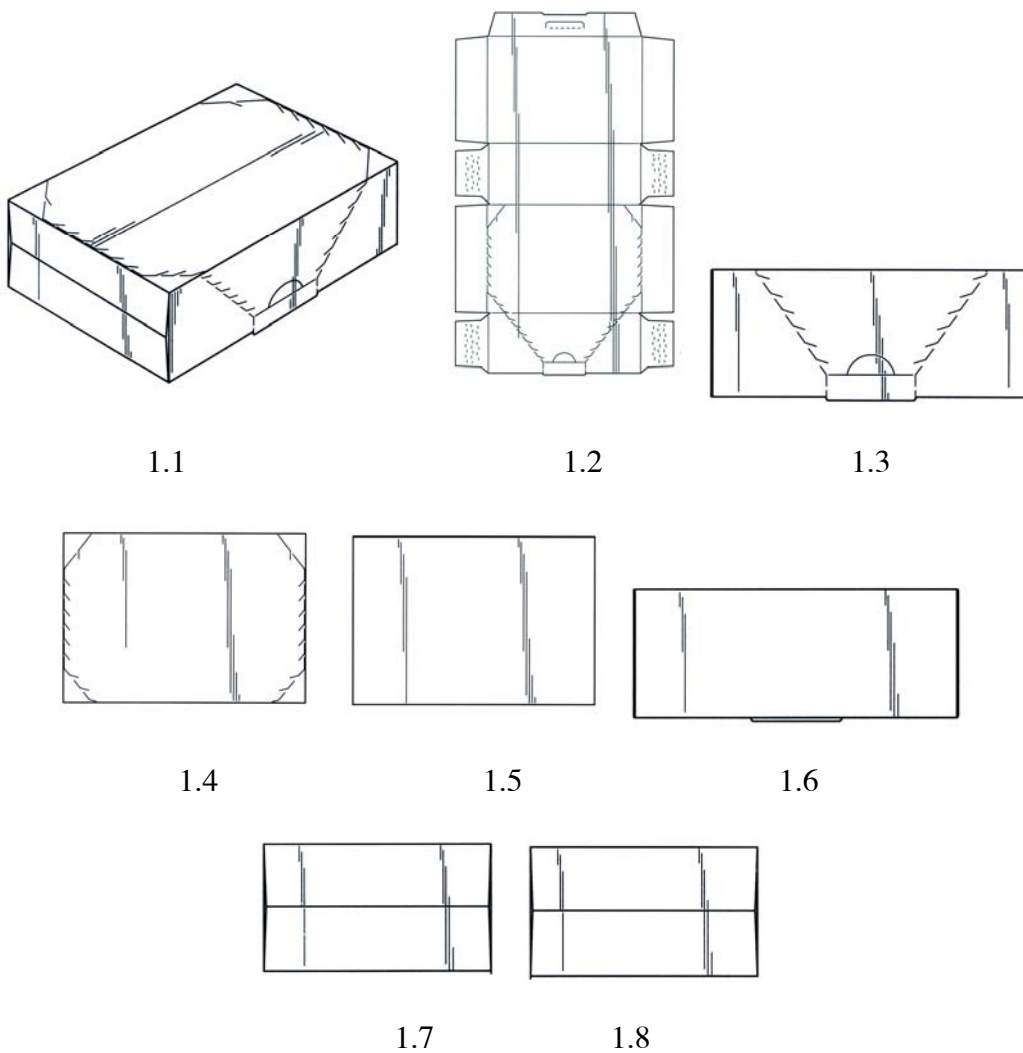

- (11) **13827**
 (21) 3-2008-01197 (28) 01
 (54) MÁY GIẶT (51) **15-05**
 (22) 29.08.2008 (43) 25.12.2008
 (30) 2008-010224 21.04.2008 JP
 (71) 1. Kabushiki Kaisha Toshiba (JP)
 1-1, Shibaura 1-chome, Minato-ku, Tokyo, Japan
 2. TOSHIBA HOME APPLIANCES CORPORATION (JP)
 2-15, Sotokanda 2-chome, Chiyoda-ku, Tokyo, Japan
 (72) Toshiaki Takama (JP), Motoyuki Suzuki (JP), Keita Matsumoto (JP)
 (74) Công ty TNHH một thành viên Sở hữu trí tuệ VCCI (VCCI-IP CO.,LTD)
 (55)

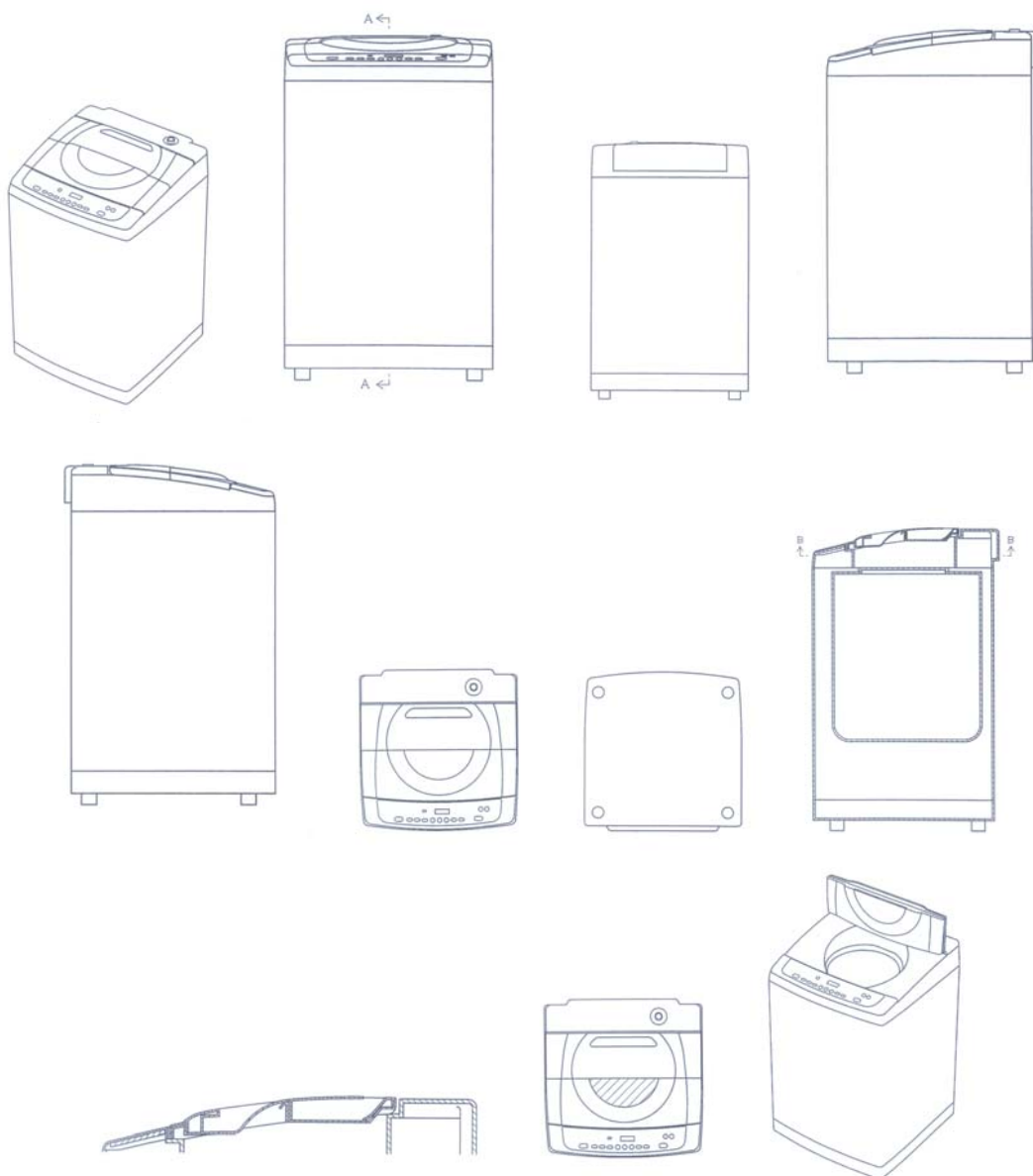

- (11) **13828**
(21) 3-2008-01206 (28) 01
(54) THÙNG RÁC (51) **09-09**
(22) 04.09.2008 (43) 25.12.2008
(71) CÔNG TY CỔ PHẦN QUẢNG CÁO LÝ TƯỞNG (VN)
80/3 Bà Huyện Thanh Quan, phường 9, quận 3, TP. Hồ Chí Minh
(72) Phạm Trần Hoàng Nguyễn (VN)
(55)



1.1

1.2

1.3

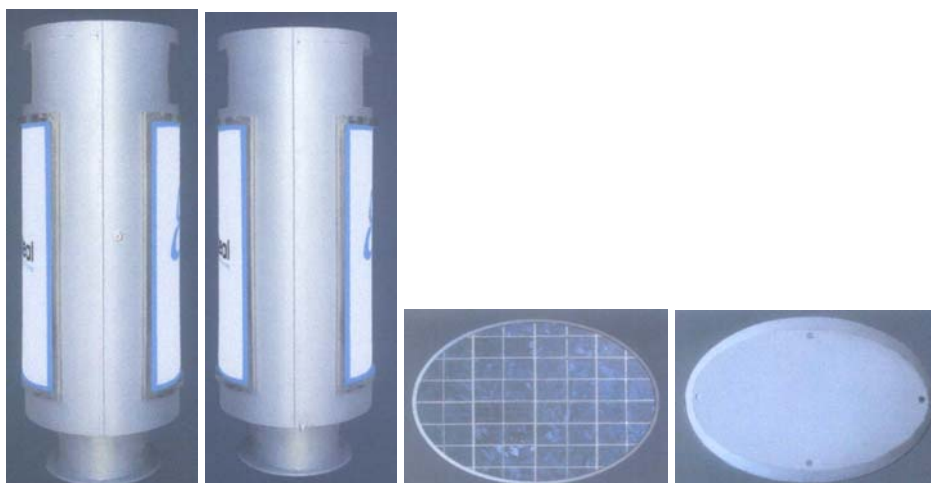

1.4

1.5

1.6

1.7

- (11) **13829**
(21) 3-2008-01207 (28) 01
(54) NHÃN SẢN PHẨM (51) **19-08**
(22) 04.09.2008 (43) 25.12.2008
(71) CÔNG TY TNHH SẢN XUẤT THƯƠNG MẠI DỊCH VỤ HỒ HUỖNH KÝ (VN)
270 Tạ Quang Bửu, phường 4, quận 8, TP. Hồ Chí Minh
(72) Hồ Hữu Hạnh (VN)
(55)



- (11) **13830**
(21) 3-2008-01208 (28) 01
(54) NHÃN SẢN PHẨM (51) **19-08**
(22) 04.09.2008 (43) 25.12.2008
(71) CÔNG TY TNHH SẢN XUẤT THƯƠNG MẠI DỊCH VỤ HỒ HUỖNH KÝ (VN)
270 Tạ Quang Bửu, phường 4, quận 8, TP. Hồ Chí Minh
(72) Hồ Hữu Hạnh (VN)
(55)



- (11) **13831**
 (21) 3-2008-01217 (28) 01
 (54) LỒNG GIẶT CỦA MÁY GIẶT (51) **15-05**
 (22) 05.09.2008 (43) 25.12.2008
 (30) 2008-005712 07.03.2008 JP
 (71) 1. KABUSHIKI KAISHA TOSHIBA, also trading as TOSHIBA CORPORATION (JP)
 1-1, Shibaura 1-chome, Minato-ku, Tokyo, Japan
 2. TOSHIBA HOME APPLIANCES CORPORATION (JP)
 2-2-15, Sotokanda, Chiyoda-ku, Tokyo, Japan
 (72) Toshiaki Takama (JP)
 (74) Công ty TNHH một thành viên Sở hữu trí tuệ VCCI (VCCI-IP CO.,LTD)
 (55)



1.1

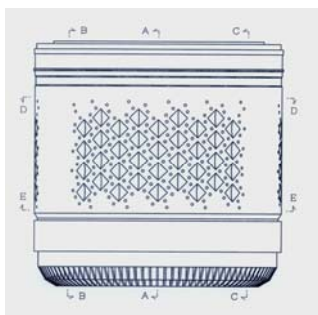

1.2



1.3

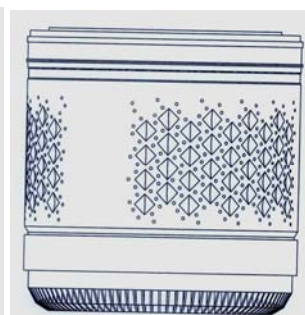

1.4



1.4

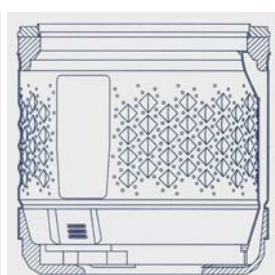

1.5



1.6

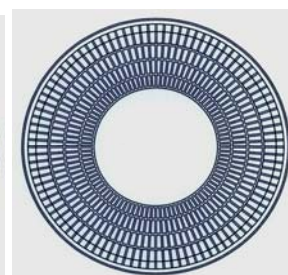

1.7

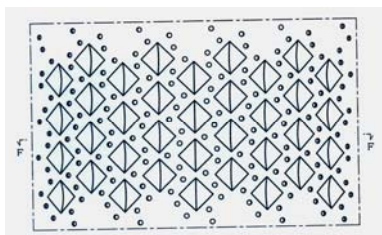

1.8



1.9

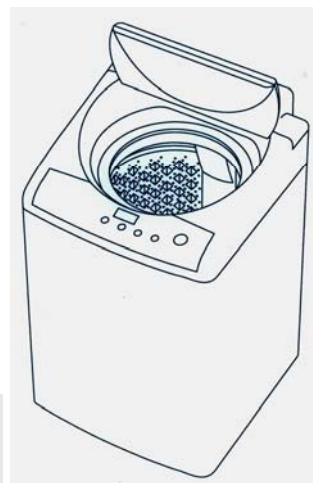

1.10

- (11) **13832**
(21) 3-2008-01218 (28) 01
(54) ỚNG ĐỰNG ĐŨA (51) **07-06**
(22) 05.09.2008 (43) 25.12.2008
(71) CÔNG TY TNHH SẢN XUẤT - THƯƠNG MẠI VÀ DỊCH VỤ TRUNG VIỆT HÙNG (VN)
235/21 Bãi Sậy, phường 4, quận 6, TP. Hồ Chí Minh
(72) Nguyễn Văn Trung (VN)
(74) Công ty Cổ phần Sở hữu công nghiệp INVESTIP (INVESTIP)
(55)



1.1

1.2

1.3



1.4

1.5

1.6

1.7

- (11) **13833**
(21) 3-2008-01224 (28) 02
(54) CÁI LƯỘC (51) **28-03**
(22) 09.09.2008 (43) 25.12.2008
(30) 895172(0001&0002) 10.03.2008 EM
(71) ACTERVIS, GMBH (CH)
c/o PRV Provides Treuhandgesellschaft Lindenhof/Dorfstrasse 38, CH-6341 Barr/Zug,
Switzerland
(72) TORRES MARTIN, Juan Ramón (ES)
(74) Công ty TNHH Sở hữu trí tuệ Thảo Thọ Quyến (INVENCO)
(55)



1.1



1.2

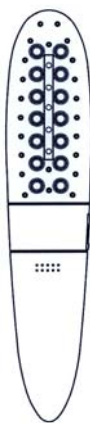

1.3



1.4



1.5

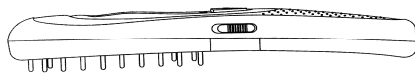

1.6



1.7

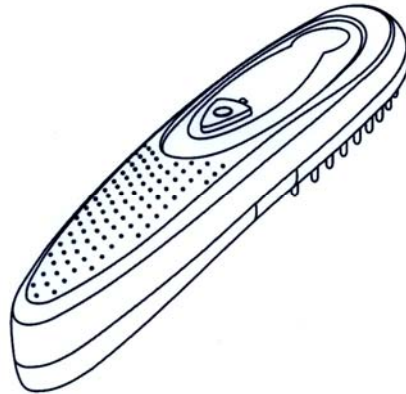

2.1

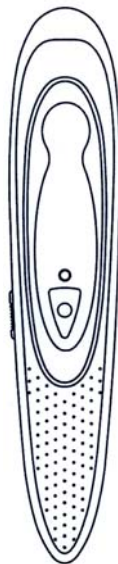

2.2

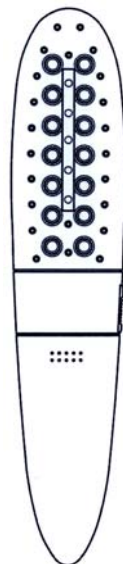

2.3



2.4



2.5

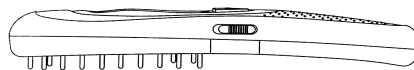

2.6

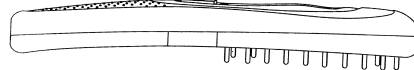

2.7

- (11) **13834**
(21) 3-2008-01231 (28) 01
(54) GIÁ ĐỂ CỐC, BÀN CHẢI ĐÁNH (51) **23-02**
RĂNG
(22) 10.09.2008 (43) 25.12.2008
(71) CÔNG TY TNHH MỘT THÀNH VIÊN SẢN XUẤT - DỊCH VỤ - THƯƠNG MẠI
KIẾNG TẤN PHÁT (VN)
Số 382/25 khu phố 8 Chiến Lược, phường Bình Trị Đông A, quận Bình Tân, TP. Hồ Chí Minh
(72) Võ Tấn Đạt (VN)
(74) Công ty TNHH Tâm nhìn và Liên danh (VISION & ASSOCIATES CO.LTD.)
(55)



1.1



1.2



1.3



1.4



1.5

- (11) **13835**
(21) 3-2008-01233 (28) 01
(54) CHAI (51) **09-01**
(22) 11.09.2008 (43) 25.12.2008
(71) CÔNG TY TNHH SẢN XUẤT THƯƠNG MẠI NHÂN LỘC (VN)
50 Ký Hòa, phường 11, quận 5, TP. Hồ Chí Minh
(72) Lê Hữu Lộc (VN)
(74) Trung tâm tư vấn phát triển Thương hiệu và Chất lượng (NATUSI)
(55)



1.1

1.2

1.3

1.4



1.5

1.6

- (11) **13836**
(21) 3-2008-01235 (28) 01
(54) MÁY KÉO (51) **12-09**
(22) 11.09.2008 (43) 25.12.2008
(30) 2008-007833 28.03.2008 JP
(71) KUBOTA CORPORATION (JP)
2-47, Shikitsuhigashi 1-chome, Naniwa-ku, Osaka-shi, Osaka 5568601, Japan
(72) Junta KUWAE (JP)
(74) Công ty TNHH một thành viên Sở hữu trí tuệ VCCI (VCCI-IP CO.,LTD)
(55)



1.1



1.2



1.3



1.4



1.5



1.6



1.7



1.8

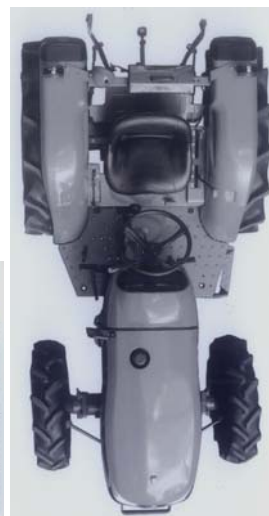

1.9



1.10



1.11

- (11) **13837**
(21) 3-2008-01239 (28) 01
(54) TẤM NÂNG HÀNG (51) **09-08**
(22) 11.09.2008 (43) 25.12.2008
(71) CÔNG TY CỔ PHẦN ĐẠI ĐỒNG TIẾN (VN)
216 Tân Thành, phường 15, quận 5, TP. Hồ Chí Minh
(72) Trịnh Đồng (VN)
(74) DNTN Dịch vụ thương mại và sở hữu công nghiệp Song Ngọc (I.P.T.S.)
(55)

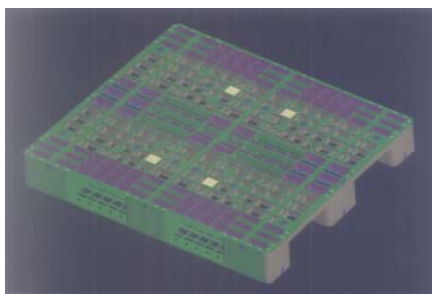

1.1

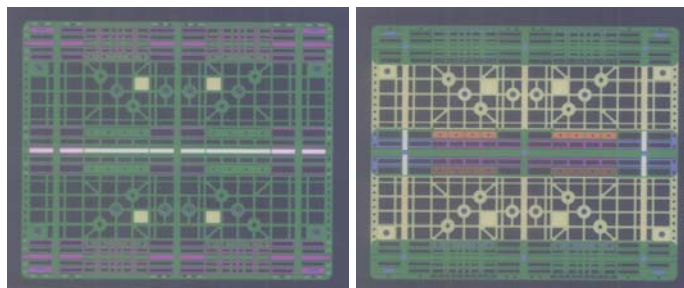

1.2

1.3



1.4

1.5

- (11) **13838**
(21) 3-2008-01245 (28) 01
(54) BÓNG ĐÈN (51) **26-04**
(22) 12.09.2008 (43) 25.12.2008
(30) 30-2008-0010924 13.03.2008 KR
(71) FAWOO TECHNOLOGY CO., LTD. (KR)
102-802, Bucheon Technopark, 364 Samjeong-dong, Ojeong-gu, Bucheon-si, Gyeonggi-do 421-809, Republic of Korea
(72) YOO, Young Ho (KR)
(74) Công ty TNHH Sở hữu trí tuệ WINCO (WINCO CO., LTD.)
(55)

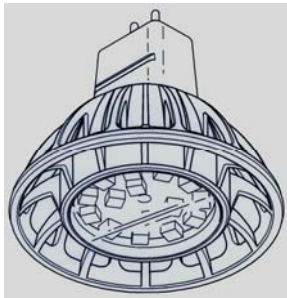

1.1

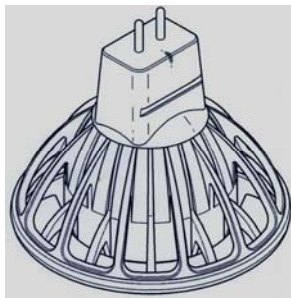

1.2

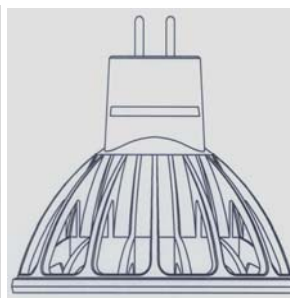

1.3

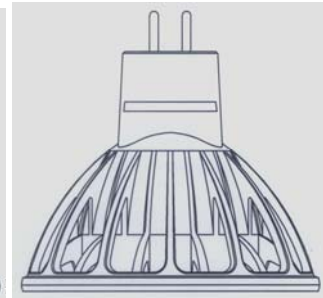

1.4

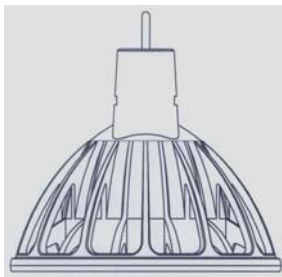

1.5

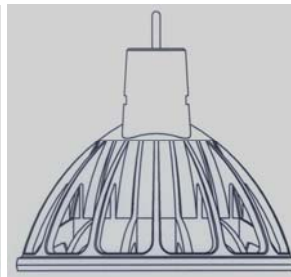

1.6

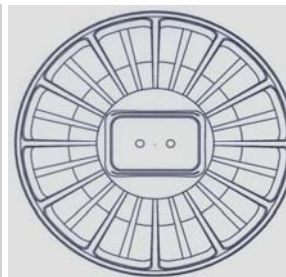

1.7

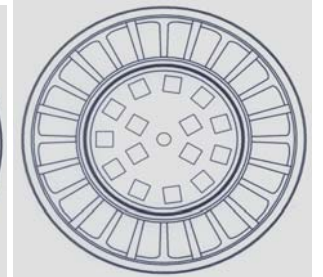

1.8

- (11) **13839**
(21) 3-2008-01252 (28) 01
(54) CHAI (51) **09-01**
(22) 15.09.2008 (43) 25.12.2008
(71) CÔNG TY TRÁCH NHIỆM HỮU HẠN THỦY SẢN TÚ HẢI (VN)
Số 294, phố Bạch Mai, phường Bạch Mai, quận Hai Bà Trưng, thành phố Hà Nội
(72) Vũ Tiến Dũng (VN)
(74) Công ty TNHH Sở hữu trí tuệ và Công nghệ Thủ đô (CAPITAL IP&T CO.LTD.)
(55)



1.1

1.2

1.3

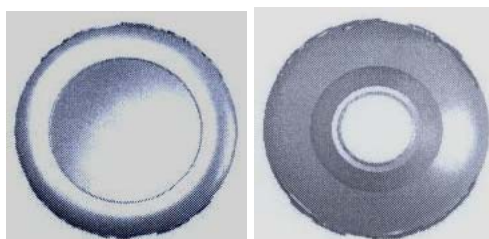

1.4

1.5

- (11) **13840**
(21) 3-2008-01253 (28) 01
(54) CHAI (51) **09-01**
(22) 15.09.2008 (43) 25.12.2008
(71) CÔNG TY TRÁCH NHIỆM HỮU HẠN THỦY SẢN TỨ HẢI (VN)
Số 294, phố Bạch Mai, phường Bạch Mai, quận Hai Bà Trưng, thành phố Hà Nội
(72) Vũ Tiến Dũng (VN)
(74) Công ty TNHH Sở hữu trí tuệ và Công nghệ Thủ đô (CAPITAL IP&T CO.LTD.)
(55)



1.1

1.2

1.3

1.4

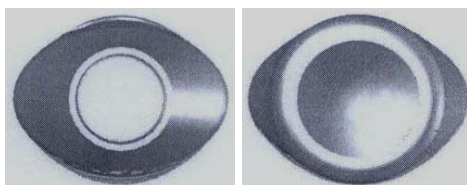

1.5

1.6

- (11) **13841**
(21) 3-2008-01266
(54) KHĂN LAU DẠNG ỐNG TRÒN
(22) 17.09.2008
(71) NGUYỄN THU HÀ (VN)
3b, A17, TT X20, Phương Liệt, quận Thanh Xuân, thành phố Hà Nội
(72) Nguyễn Thu Hà (VN)
(55)
- (28) 01
(51) **19-06**
(43) 25.12.2008



1.1

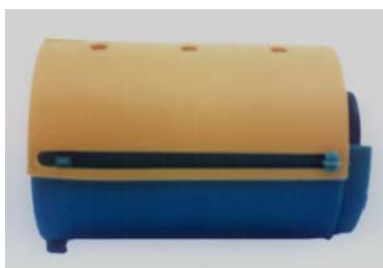

1.2



1.3



1.4



1.5



1.6



1.7



1.8



1.19



1.10



1.11



1.12

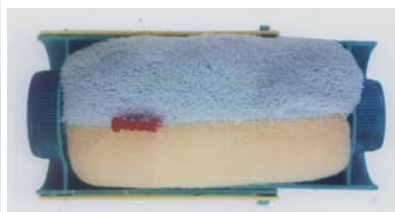

1.13

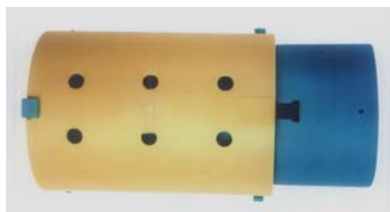

1.14



1.15

- (11) **13842**
(21) 3-2008-01267 (28) 01
(54) ĐĨA (51) **07-01**
(22) 17.09.2008 (43) 25.12.2008
(71) CÔNG TY TRÁCH NHIỆM HỮU HẠN MINH LONG I (VN)
333 xã Hưng Định, huyện Thuận An, tỉnh Bình Dương
(72) Lý Ngọc Minh (VN)
(74) Công ty TNHH Lê & Lê (LE & LE)
(55)



1.1

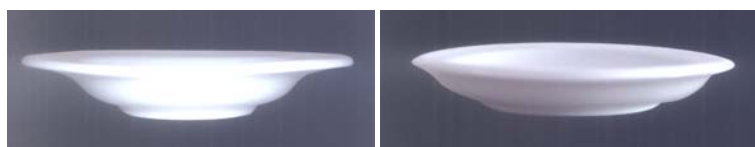

1.2

1.3

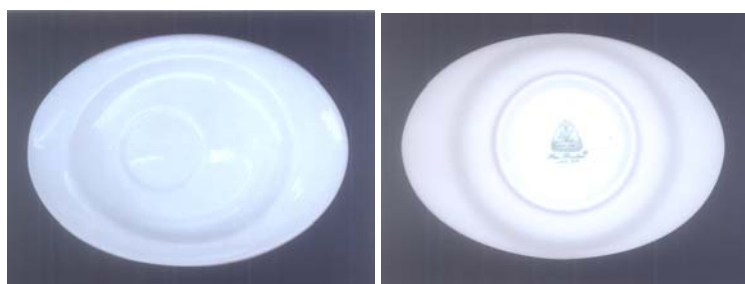

1.4

1.5

- (11) **13843**
(21) 3-2008-01288 (28) 01
(54) Ổ KHOÁ (51) **08-07**
(22) 22.09.2008 (43) 25.12.2008
(71) NGUYỄN HOÀI NHI (VN)
xã Truong Mít, Dương Minh Châu, tỉnh Tây Ninh
(72) Nguyễn Hoài Nhi (VN)
(74) Công ty Cổ phần Sở hữu công nghiệp INVESTIP (INVESTIP)
(55)



1.1



1.2

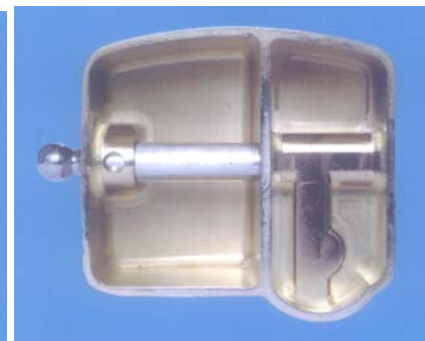

1.3



1.4

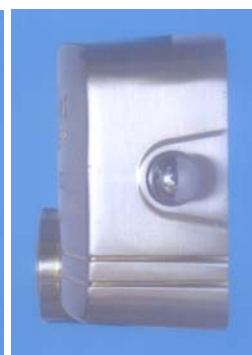

1.5



1.6



1.7

- (11) **13844**
(21) 3-2008-01295
(54) ĐÈN
(22) 25.09.2008
(71) CÔNG TY TNHH BẢO ĐĂNG (VN)
139/12 Đinh Bộ Lĩnh, phường 26, quận Bình Thạnh, TP. Hồ Chí Minh
(72) Nguyễn Trọng Kha (FR)
(55)
- (28) 01
(51) **26-05**
(43) 25.12.2008



1.1

1.2

1.3

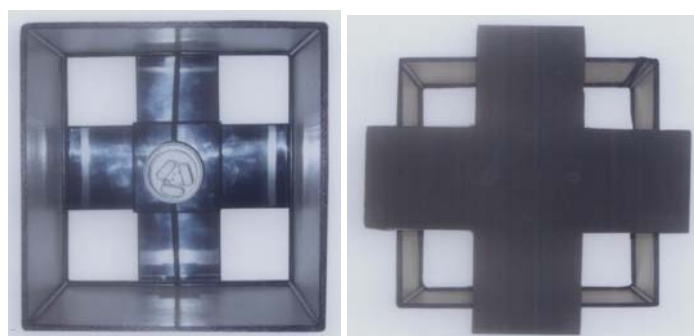

1.4

1.5

- (11) **13845**
(21) 3-2008-01296
(54) ĐÈN
(22) 25.09.2008
(71) CÔNG TY TNHH BẢO ĐĂNG (VN)
139/12 Đinh Bộ Lĩnh, phường 26, quận Bình Thạnh, TP. Hồ Chí Minh
(72) Nguyễn Trọng Kha (FR)
(55)
- (28) 01
(51) **26-05**
(43) 25.12.2008



1.1



1.2



1.3



1.4

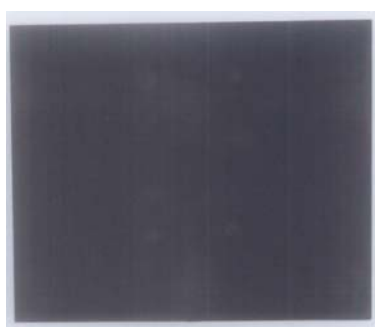

1.5

- (11) **13846**
(21) 3-2008-01302
(54) KÉO
(22) 25.09.2008
(71) ĐOÀN VĂN TIẾN (VN)
61/17/14A Đất Thánh, phường 6, quận Tân Bình, TP. Hồ Chí Minh
(72) Đoàn Văn Tiến (VN)
(74) DNTN Dịch vụ thương mại và sở hữu công nghiệp Song Ngọc (I.P.T.S.)
(55)
- (28) 01
(51) **08-03**
(43) 25.12.2008



1.1

1.2

1.3

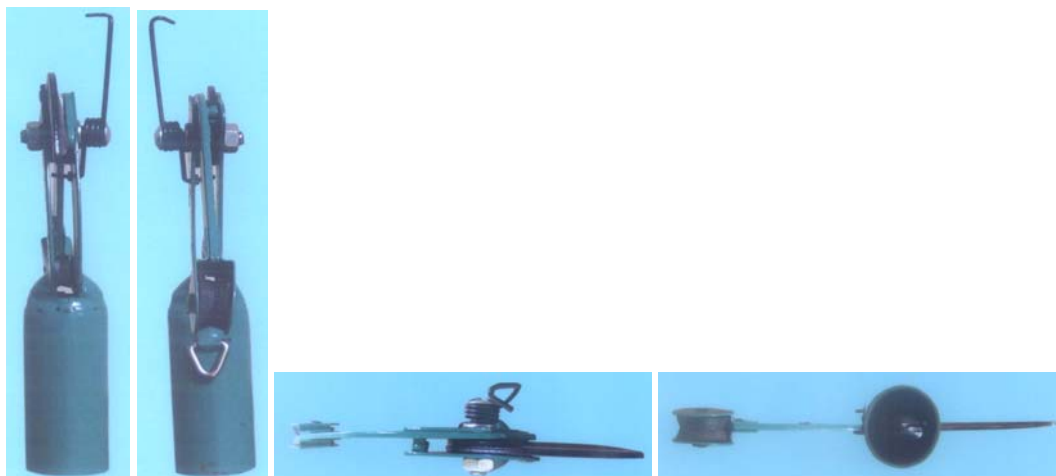

1.4

1.5

1.6

1.7

- (11) **13847**
(21) 3-2008-01303 (28) 01
(54) MÁY BƠM (51) **15-02**
(22) 25.09.2008 (43) 25.12.2008
(71) CÔNG TY TNHH SẢN XUẤT - XÂY DỰNG - THƯƠNG MẠI VĨNH ĐÔNG (VN)
151 Khuông Việt, phường Phú Trung, quận Tân Phú, TP. Hồ Chí Minh
(72) Huỳnh Văn Tiêl (VN)
(74) DNTN Dịch vụ thương mại và sở hữu công nghiệp Song Ngọc (I.P.T.S.)
(55)



1.1



1.2



1.3



1.4



1.5



1.6



1.7

- (11) **13848**
(21) 3-2008-01304 (28) 01
(54) BỒN RỬA (51) **23-02**
(22) 25.09.2008 (43) 25.12.2008
(71) CÔNG TY TRÁCH NHIỆM HỮU HẠN LA MÃ (VN)
Số 207, ấp 3A, xã Phước Lợi, huyện Bến Lức, tỉnh Long An
(72) Đỗ Uy Duy (VN)
(74) Công ty TNHH Sở hữu trí tuệ Thảo Thọ Quyến (INVENCO)
(55)

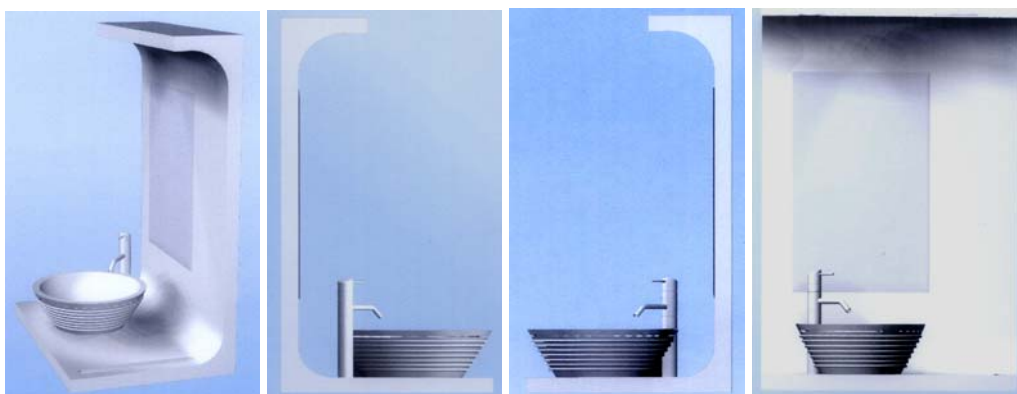

1.1

1.2

1.3

1.4

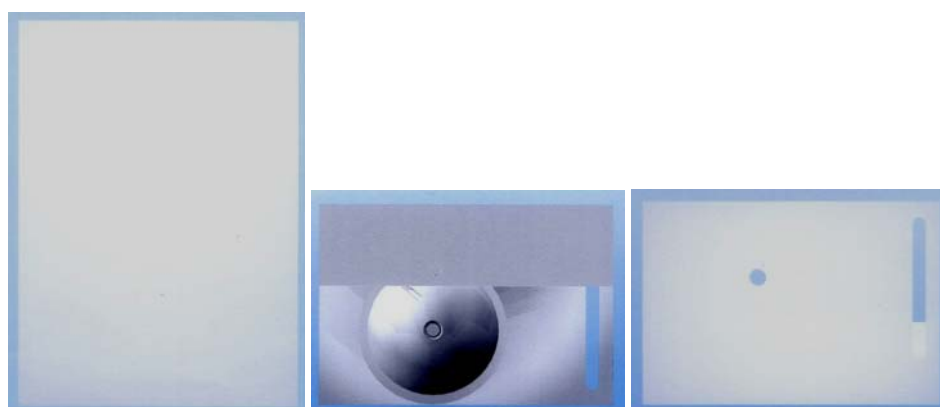

1.5

1.6

1.7

CÔNG BÁO SỞ HỮU CÔNG NGHIỆP SỐ 249 TẬP A (12.2008)

- (11) **13849**
(21) 3-2008-01305 (28) 04
(54) BAO BÌ (51) **09-05**
(22) 25.09.2008 (43) 25.12.2008
(71) CÔNG TY CỔ PHẦN CÔNG NGHIỆP THƯƠNG MẠI MA SAN (VN)
Tầng 9, toà nhà Etown 2, 364 Cộng Hoà, phường 13, quận Tân Bình, TP. Hồ Chí Minh
(72) Trương Công Thắng (VN)
(74) Công ty TNHH Sở hữu trí tuệ Thảo Thọ Quyến (INVENCO)
(55)



1.1



1.2



2.1



2.2



3.1



3.2



4.1



4.2

- (11) **13850**
(21) 3-2008-01306
(54) ĐÈN
(22) 25.09.2008
(71) CÔNG TY TNHH BẢO ĐĂNG (VN)
139/12 Đinh Bộ Lĩnh, phường 26, quận Bình Thạnh, TP. Hồ Chí Minh
(72) Trần Thành Nhân (FR)
(55)
- (28) 01
(51) **26-05**
(43) 25.12.2008

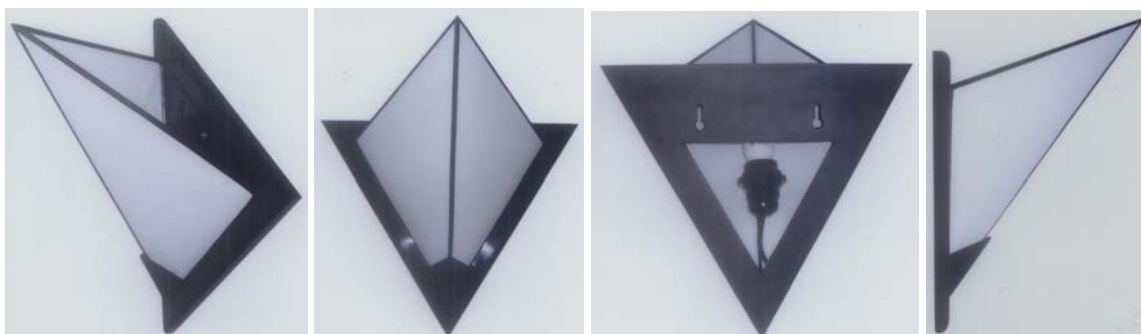

1.1

1.2

1.3

1.4



1.5

1.6

- (11) **13851**
(21) 3-2008-01307
(54) ĐÈN
(22) 25.09.2008
(71) CÔNG TY TNHH BẢO ĐĂNG (VN)
139/12 Đinh Bộ Lĩnh, phường 26, quận Bình Thạnh, TP. Hồ Chí Minh
(72) Nguyễn Trọng Kha (FR)
(55)
- (28) 01
(51) **26-05**
(43) 25.12.2008



1.1

1.2

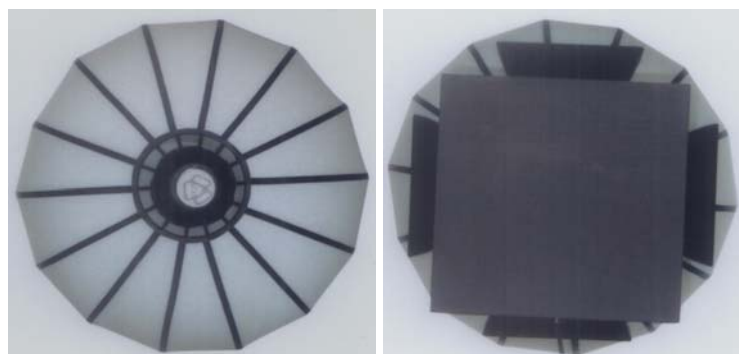

1.3

1.4

- (11) **13852**
(21) 3-2008-01308
(54) ĐÈN
(22) 25.09.2008
(71) CÔNG TY TNHH BẢO ĐĂNG (VN)
139/12 Đinh Bộ Lĩnh, phường 26, quận Bình Thạnh, TP. Hồ Chí Minh
(72) Phùng Hữu Năng (VN)
(55)
- (28) 01
(51) **26-05**
(43) 25.12.2008

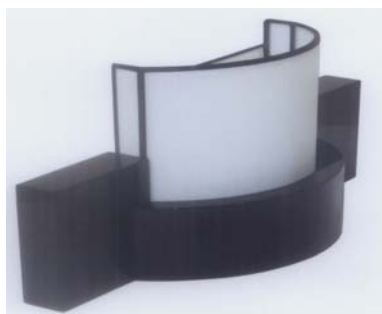

1.1



1.2



1.3



1.4



1.5



1.6

- (11) **13853**
(21) 3-2008-01309
(54) ĐÈN
(22) 25.09.2008
(71) CÔNG TY TNHH BẢO ĐĂNG (VN)
139/12 Đinh Bộ Lĩnh, phường 26, quận Bình Thạnh, TP. Hồ Chí Minh
(72) Phùng Hữu Năng (VN)
(55)
- (28) 01
(51) **26-05**
(43) 25.12.2008

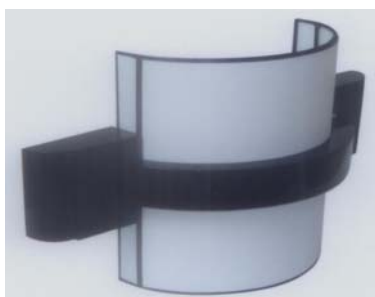

1.1

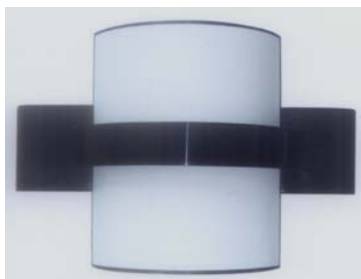

1.2

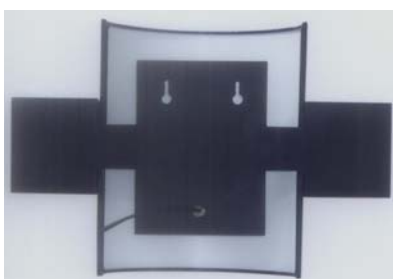

1.3



1.4



1.5



1.6

- (11) **13854**
(21) 3-2008-01310
(54) ĐÈN
(22) 25.09.2008
(71) CÔNG TY TNHH BẢO ĐĂNG (VN)
139/12 Đinh Bộ Lĩnh, phường 26, quận Bình Thạnh, TP. Hồ Chí Minh
(72) Bùi Huy Lam (US)
(55)
- (28) 01
(51) **26-05**
(43) 25.12.2008

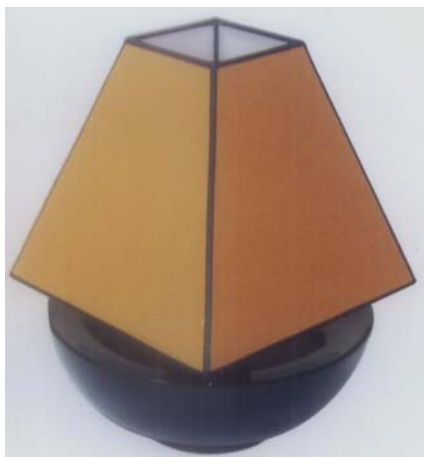

1.1



1.2



1.3



1.4

- (11) **13855**
(21) 3-2008-01314
(54) ĐÈN
(22) 25.09.2008
(71) CÔNG TY TNHH BẢO ĐĂNG (VN)
139/12 Đinh Bộ Lĩnh, phường 26, quận Bình Thạnh, TP. Hồ Chí Minh
(72) Trần Thành Nhân (FR)
(55)
- (28) 01
(51) **26-05**
(43) 25.12.2008



1.1

1.2

1.3

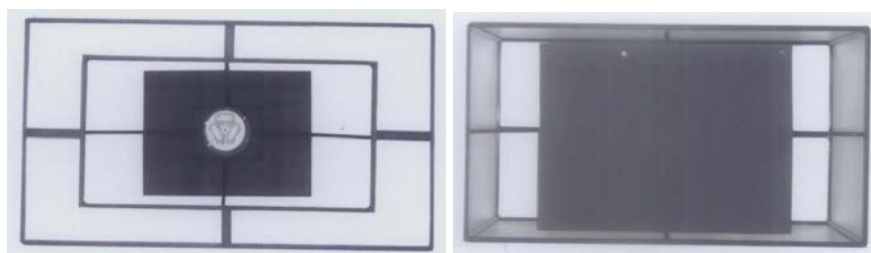

1.4

1.5

- (11) **13856**
(21) 3-2008-01315
(54) ĐÈN
(22) 25.09.2008
(71) CÔNG TY TNHH BẢO ĐĂNG (VN)
139/12 Đinh Bộ Lĩnh, phường 26, quận Bình Thạnh, TP. Hồ Chí Minh
(72) Phạm Mạnh Hùng (FR)
(55)
- (28) 01
(51) **26-05**
(43) 25.12.2008



1.1

1.2

1.3



1.4

1.5

- (11) **13857**
(21) 3-2008-01322
(54) ĐÈN
(22) 25.09.2008
(71) CÔNG TY TNHH BẢO ĐĂNG (VN)
139 Đinh Bộ Lĩnh, phường 26, quận Bình Thạnh, TP. Hồ Chí Minh
(72) Nguyễn Văn Lang (VN)
(55)
- (28) 01
(51) **26-05**
(43) 25.12.2008



1.1

1.2

1.3



1.4

1.5

1.6

- (11) **13858**
(21) 3-2008-01323
(54) ĐÈN
(22) 25.09.2008
(71) CÔNG TY TNHH BẢO ĐĂNG (VN)
139/12 Đinh Bộ Lĩnh, phường 26, quận Bình Thạnh, TP. Hồ Chí Minh
(72) Trần Thành Nhân (FR)
(55)
- (28) 01
(51) **26-05**
(43) 25.12.2008



1.1

1.2

1.3

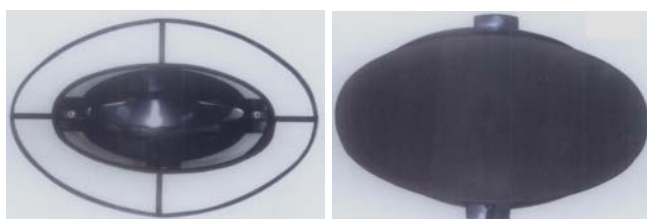

1.4

1.5

- (11) **13859**
(21) 3-2008-01324
(54) ĐÈN
(22) 25.09.2008
(71) CÔNG TY TNHH BẢO ĐĂNG (VN)
139/12 Đinh Bộ Lĩnh, phường 26, quận Bình Thạnh, TP. Hồ Chí Minh
(72) Trần Thành Nhân (FR)
(55)
- (28) 01
(51) **26-05**
(43) 25.12.2008



1.1



1.2



1.3



1.4



1.5



1.6

- (11) **13860**
(21) 3-2008-01325
(54) ĐÈN
(22) 25.09.2008
(71) CÔNG TY TNHH BẢO ĐĂNG (VN)
97 Đinh Bộ Lĩnh, phường 26, quận Bình Thạnh, TP. Hồ Chí Minh
(72) Trần Thành Nhân (FR)
(55)
- (28) 01
(51) **26-05**
(43) 25.12.2008



1.1

1.2

1.3

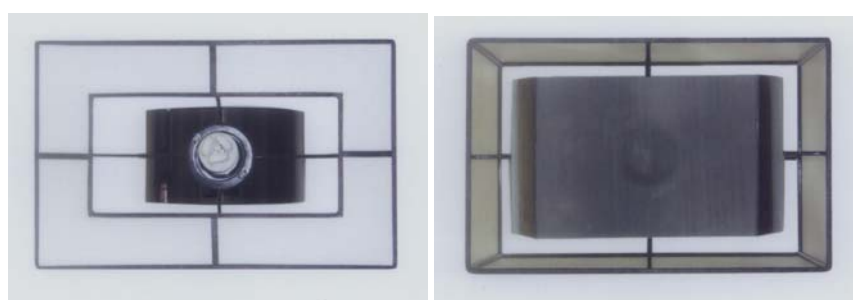

1.4

1.5

- (11) **13861**
(21) 3-2008-01326
(54) ĐÈN
(22) 25.09.2008
(71) CÔNG TY TNHH BẢO ĐĂNG (VN)
139/12 Đinh Bộ Lĩnh, phường 26, quận Bình Thạnh, TP. Hồ Chí Minh
(72) Trần Thành Nhân (FR)
(55)
- (28) 01
(51) **26-05**
(43) 25.12.2008



1.1

1.2

1.3



1.4

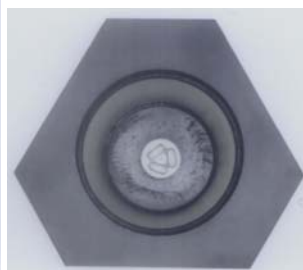

1.5



1.6

- (11) **13862**
(21) 3-2008-01327
(54) ĐÈN
(22) 25.09.2008
(71) CÔNG TY TNHH BẢO ĐĂNG (VN)
139/12 Đinh Bộ Lĩnh, phường 26, quận Bình Thạnh, TP. Hồ Chí Minh
(72) Nguyễn Văn Lang (VN)
(55)
(28) 01
(51) **26-05**
(43) 25.12.2008



1.1



1.2



1.3

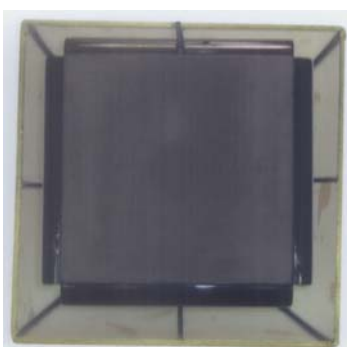

1.4

- (11) **13863**
(21) 3-2008-01328
(54) ĐÈN
(22) 25.09.2008
(71) CÔNG TY TNHH BẢO ĐĂNG (VN)
139/12 Đinh Bộ Lĩnh, phường 26, quận Bình Thạnh, TP. Hồ Chí Minh
(72) Nguyễn Trọng Kha (FR)
(55)
- (28) 01
(51) **26-05**
(43) 25.12.2008

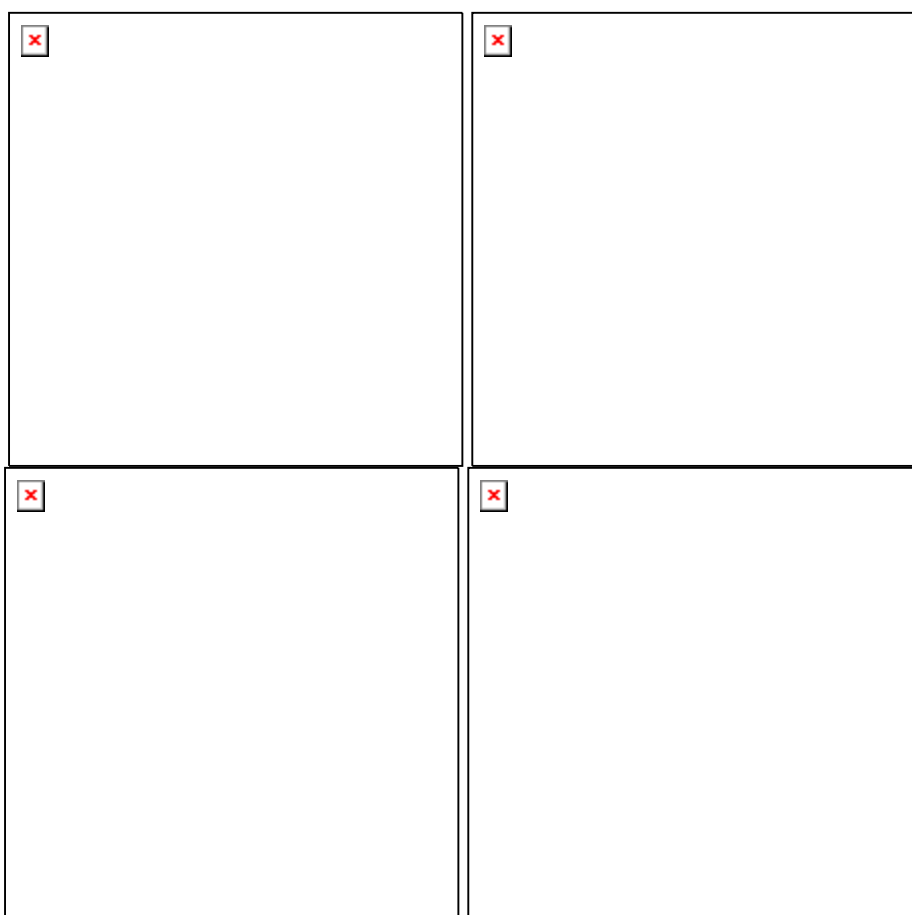

- (11) **13864**
(21) 3-2008-01331
(54) HỘP ĐỰNG THỰC PHẨM
(22) 26.09.2008
(71) PERFETTI VAN MELLE S.p.A. (IT)
VIA XXV Aprile, 7, LAINATE, ITALY
(72) Dorianò ZANALETTI (IT)
(74) Công ty TNHH Sở hữu trí tuệ WINCO (WINCO CO., LTD.)
(55)
- (28) 01
(51) **09-03**
(43) 25.12.2008

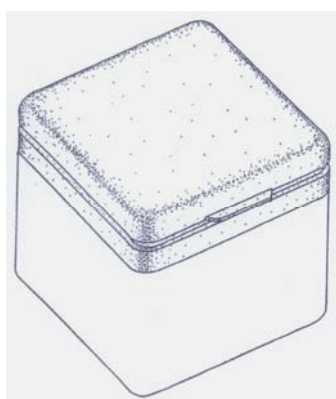

1.1

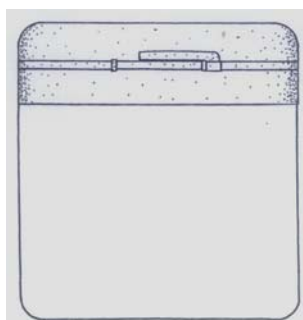

1.2



1.3

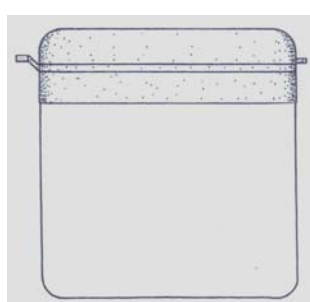

1.4



1.5



1.6

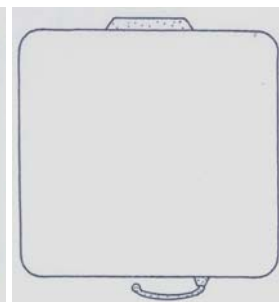

1.7

- (11) **13865**
(21) 3-2008-01335
(54) BAO GÓI BÁNH
(22) 29.09.2008
(71) NGUYỄN MY ON (VN)
ấp Thị I, thị trấn Chợ Mới, huyện Chợ Mới, tỉnh An Giang
(72) Trần Lê Hùng (VN)
(55)
(28) 01
(51) **09-05**
(43) 25.12.2008



1.1



1.2



1.3

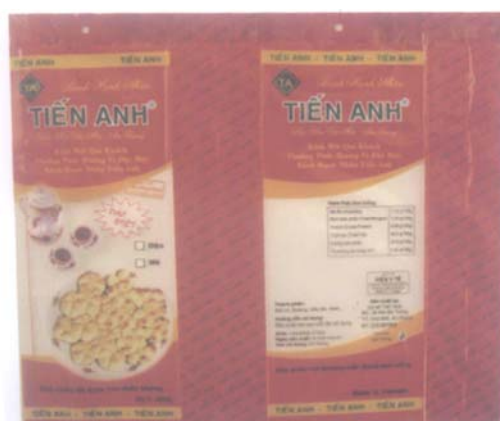

1.4



1.5

- (11) **13866**
(21) 3-2008-01337 (28) 01
(54) LỘ (51) **09-01**
(22) 29.09.2008 (43) 25.12.2008
(71) CÔNG TY TNHH SẢN XUẤT THƯƠNG MẠI NHÂN LỘC (VN)
50 Ký Hòa, phường 11, quận 5, TP. Hồ Chí Minh
(72) Lê Hữu Lộc (VN)
(74) Trung tâm tư vấn phát triển Thương hiệu và Chất lượng (NATUSI)
(55)

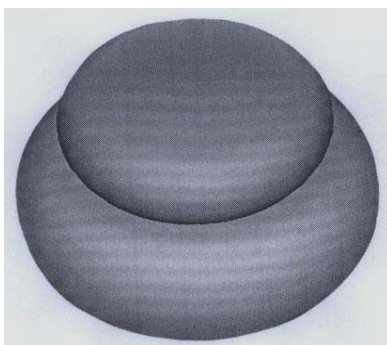

1.1

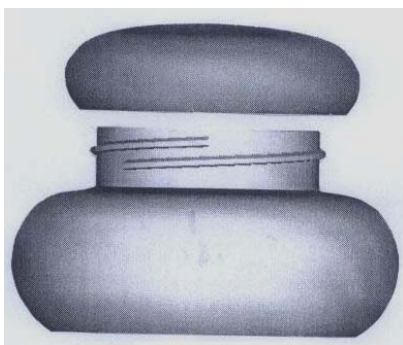

1.2

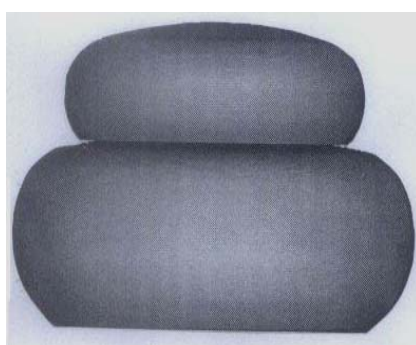

1.3

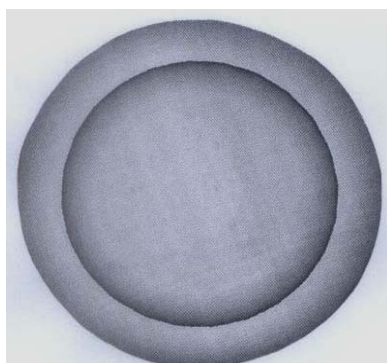

1.4

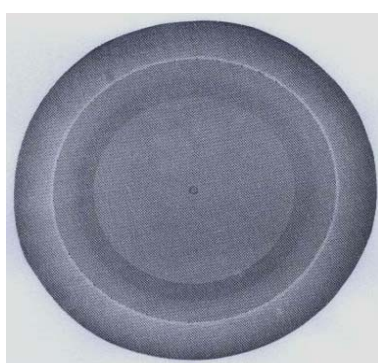

1.5

- (11) **13867**
(21) 3-2008-01341 (28) 01
(54) XE ĐẠP ĐIỆN (51) **12-11**
(22) 29.09.2008 (43) 25.12.2008
(71) CÔNG TY TNHH ĐẠI TRƯỜNG GIANG (VN)
133/17 Hoà Bình, phường Hiệp Tân, quận Tân Phú, TP. Hồ Chí Minh
(72) Nguyễn Phi Hưng (VN)
(74) Công ty TNHH Trường Xuân (AGELESS CO.,LTD.)
(55)



1.1



1.2



1.3



1.4



1.5



1.6



1.7



1.8



1.9

- (11) **13868**
(21) 3-2008-01342 (28) 01
(54) XE ĐẠP ĐIỆN (51) **12-11**
(22) 29.09.2008 (43) 25.12.2008
(71) CÔNG TY TNHH ĐẠI TRƯỜNG GIANG (VN)
133/17 Hoà Bình, phường Hiệp Tân, quận Tân Phú, TP. Hồ Chí Minh
(72) Nguyễn Phi Hưng (VN)
(74) Công ty TNHH Trường Xuân (AGELESS CO.,LTD.)
(55)



1.1



1.2



1.3



1.4



1.5



1.6



1.7



1.8



1.9

- (11) **13869**
(21) 3-2008-01343 (28) 01
(54) XE ĐẠP ĐIỆN (51) **12-11**
(22) 29.09.2008 (43) 25.12.2008
(71) CÔNG TY TNHH ĐẠI TRƯỜNG GIANG (VN)
133/17 Hoà Bình, phường Hiệp Tân, quận Tân Phú, TP. Hồ Chí Minh
(72) Nguyễn Phi Hưng (VN)
(74) Công ty TNHH Trường Xuân (AGELESS CO.,LTD.)
(55)



1.1



1.2



1.3



1.4



1.5



1.6

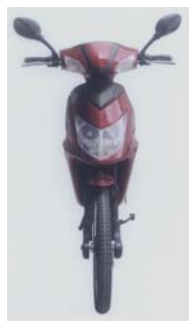

1.7



1.8



1.9

- (11) **13870**
(21) 3-2008-01344 (28) 01
(54) HỘP (51) **09-03**
(22) 29.09.2008 (43) 25.12.2008
(71) CÔNG TY CỔ PHẦN DIỆU THƯỜNG (VN)
ấp Long Đức 1, xã Tam Phước, huyện Long Thành, tỉnh Đồng Nai
(72) Lương Huệ Phương (VN)
(74) Công ty Cổ phần Sở hữu công nghiệp INVESTIP (INVESTIP)
(55)



1.1



1.2

- (11) **13871**
(21) 3-2008-01345 (28) 01
(54) HỘP (51) **09-03**
(22) 29.09.2008 (43) 25.12.2008
(71) CÔNG TY CỔ PHẦN DIỆU THƯỜNG (VN)
ấp Long Đức 1, xã Tam Phước, huyện Long Thành, tỉnh Đồng Nai
(72) Lương Huệ Phương (VN)
(74) Công ty Cổ phần Sở hữu công nghiệp INVESTIP (INVESTIP)
(55)



1.1



1.2

- (11) **13872**
(21) 3-2008-01348 (28) 01
(54) MÁY LỌC NƯỚC NÓNG LẠNH (51) **23-01**
(22) 30.09.2008 (43) 25.12.2008
(30) 2008-009302 11.04.2008 JP
(71) HOKUEI CORPORATION (JP)
1-17, Higashikasai 6-chome, Edogawa-ku, Tokyo 134-0084, Japan
(72) Koji NAKAHARA (JP)
(74) Công ty TNHH Sở hữu trí tuệ Thảo Thọ Quyển (INVENCO)
(55)

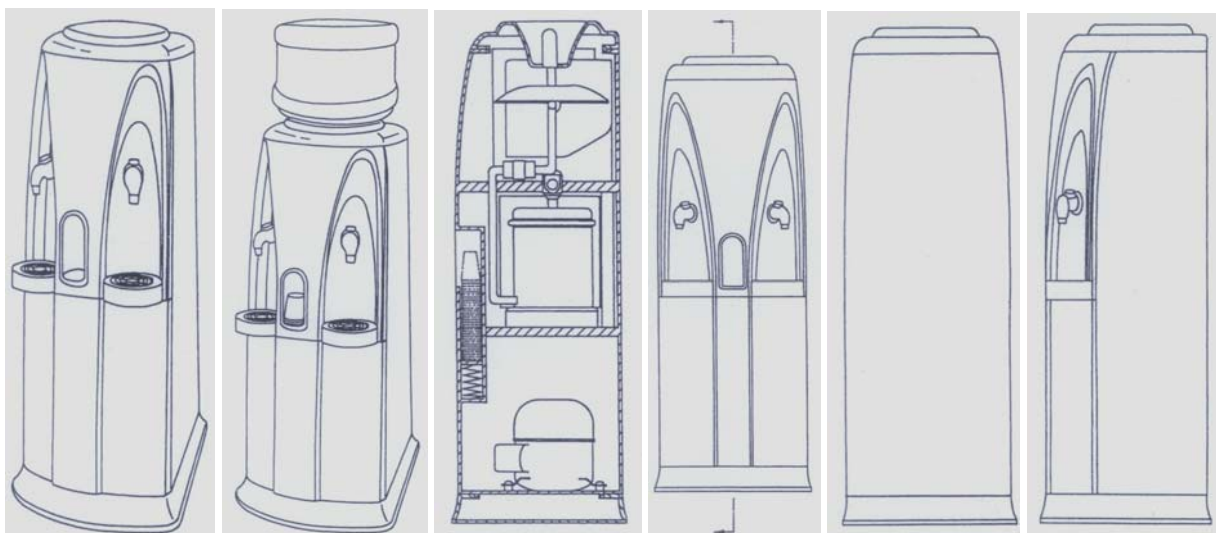

1.1

1.2

1.3

1.4

1.5

1.6

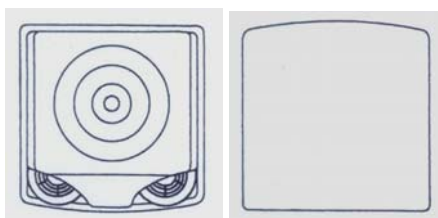

1.7

1.8

- (11) **13873**
(21) 3-2008-01349 (28) 01
(54) XE ĐẨY TRẺ EM (51) 12-12
(22) 30.09.2008 (43) 25.12.2008
(71) NGUYỄN KỲ TRUNG (VN)
670 Phạm Thế Hiển, phường 4, quận 8, TP. Hồ Chí Minh
(72) Nguyễn Kỳ Trung (VN)
(55)



1.1

1.2

1.3

1.4



1.5

1.6

1.7

- (11) **13874**
(21) 3-2008-01350 (28) 01
(54) XE ĐẨY TRẺ EM (51) **12-12**
(22) 30.09.2008 (43) 25.12.2008
(71) NGUYỄN KỶ TRUNG (VN)
670 Phạm Thế Hiển, phường 4, quận 8, TP. Hồ Chí Minh
(72) Nguyễn Kỳ Trung (VN)
(55)



1.1



1.2



1.3



1.4



1.5



1.6



1.7

- (11) **13875**
(21) 3-2008-01352 (28) 01
(54) NHÃN SẢN PHẨM (51) **19-08**
(22) 30.09.2008 (43) 25.12.2008
(30) 30-2008-0014029 02.04.2008 KR
(71) LOCK & LOCK COMPANY LIMITED (KR)
Lock & Lock Bldg. 1556-1, Seocho-3 Dong, Seocho-gu, Seoul, Korea
(72) Kim Chang Ho (KR)
(74) Công ty TNHH Tầm nhìn và Liên danh (VISION & ASSOCIATES CO.LTD.)
(55)



- (11) **13876**
(21) 3-2008-01353 (28) 01
(54) NHÃN SẢN PHẨM (51) **19-08**
(22) 30.09.2008 (43) 25.12.2008
(30) 30-2008-0014030 02.04.2008 KR
(71) LOCK & LOCK COMPANY LIMITED (KR)
Lock & Lock Bldg. 1556-1, Seocho-3 Dong, Seocho-gu, Seoul, Korea
(72) Kim Chang Ho (KR)
(74) Công ty TNHH Tầm nhìn và Liên danh (VISION & ASSOCIATES CO.LTD.)
(55)

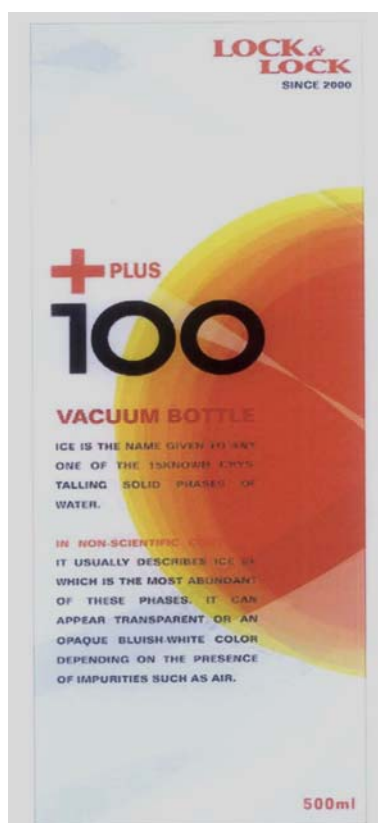

- (11) **13877**
(21) 3-2008-01354 (28) 01
(54) HỘP ĐỰNG THỰC PHẨM (51) **09-03**
(22) 30.09.2008 (43) 25.12.2008
(30) 30-2008-0015449 11.04.2008 KR
(71) LOCK & LOCK COMPANY LIMITED (KR)
Lock & Lock Bldg. 1556-1, Seocho-3 Dong, Seocho-gu, Seoul, Korea
(72) Kim Chang Ho (KR)
(74) Công ty TNHH Tầm nhìn và Liên danh (VISION & ASSOCIATES CO.LTD.)
(55)



1.1

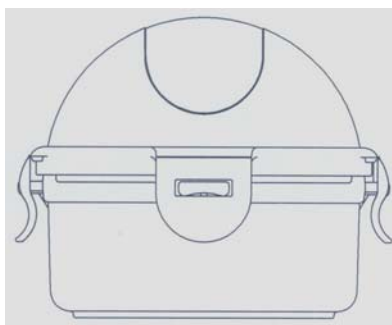

1.2



1.3

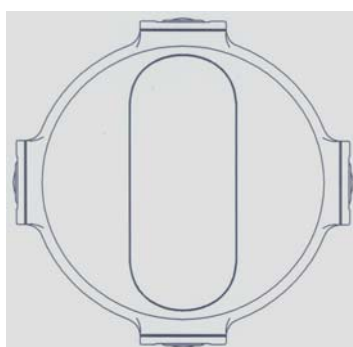

1.4

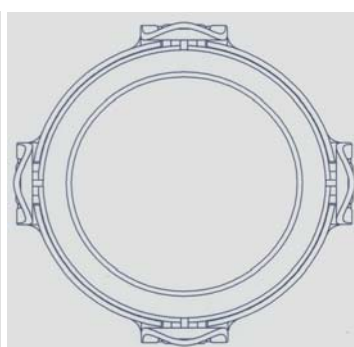

1.5

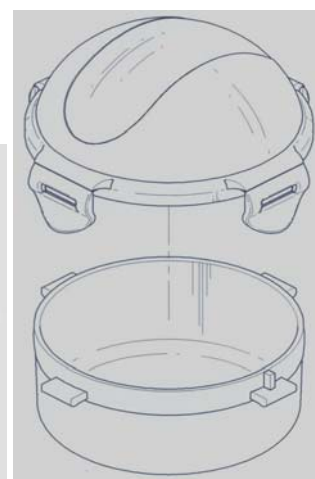

1.6

- (11) **13878**
(21) 3-2008-01355 (28) 01
(54) BÌNH (51) **09-01**
(22) 30.09.2008 (43) 25.12.2008
(30) 30-2008-0015451 11.04.2008 KR
(71) LOCK & LOCK COMPANY LIMITED (KR)
Lock & Lock Bldg. 1556-1, Seocho-3 Dong, Seocho-gu, Seoul, Korea
(72) Kim Chang Ho (KR)
(74) Công ty TNHH Tầm nhìn và Liên danh (VISION & ASSOCIATES CO.LTD.)
(55)

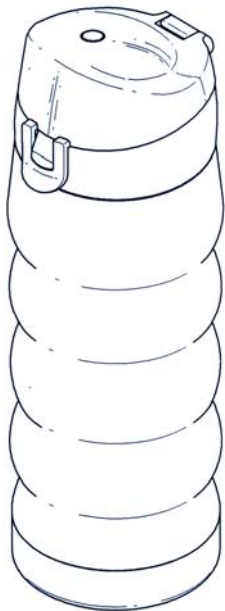

1.1

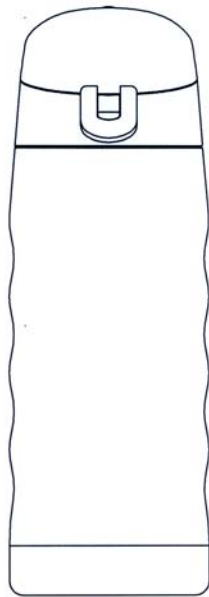

1.2

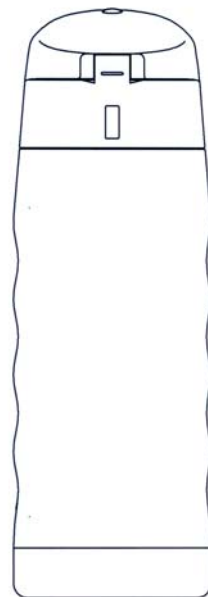

1.3

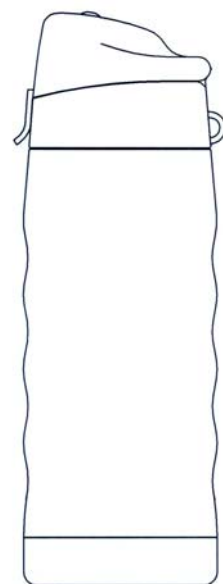

1.4

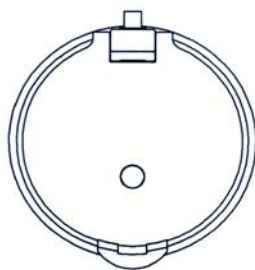

1.5

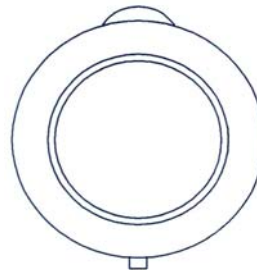

1.6

- (11) **13879**
(21) 3-2008-01356 (28) 01
(54) BÌNH (51) **09-01**
(22) 30.09.2008 (43) 25.12.2008
(30) 30-2008-0015453 11.04.2008 KR
(71) LOCK & LOCK COMPANY LIMITED (KR)
Lock & Lock Bldg. 1556-1, Seocho-3 Dong, Seocho-gu, Seoul, Korea
(72) Kim Chang Ho (KR)
(74) Công ty TNHH Tầm nhìn và Liên danh (VISION & ASSOCIATES CO.LTD.)
(55)

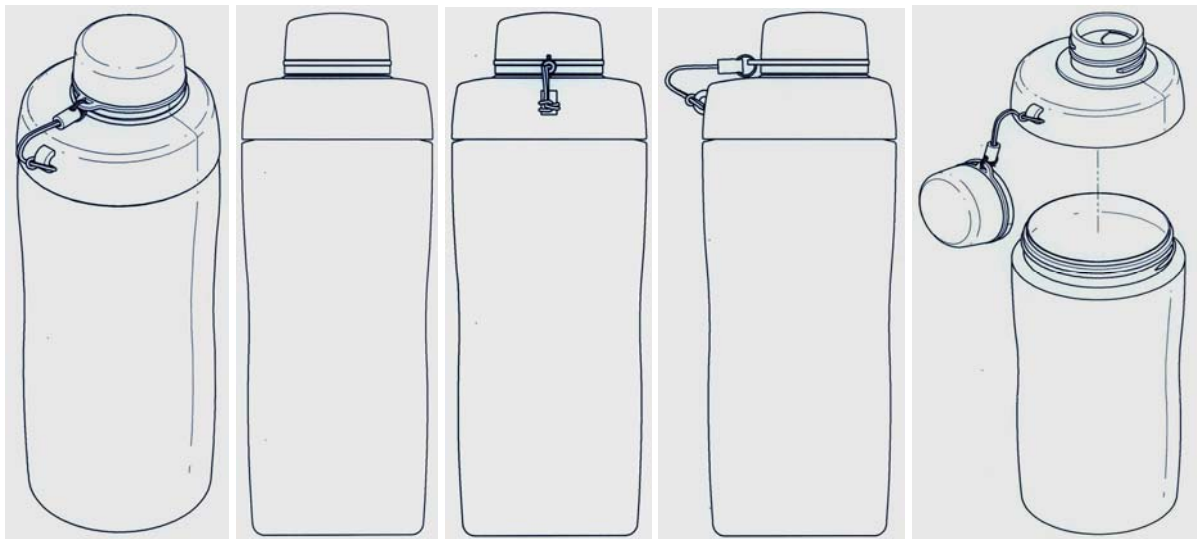

1.1

1.2

1.3

1.4

1.5

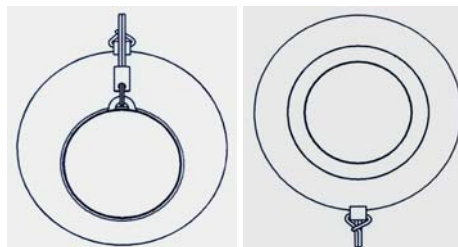

1.6

1.7

CÔNG BÁO SỞ HỮU CÔNG NGHIỆP SỐ 249 TẬP A (12.2008)

- (11) **13880**
(21) 3-2008-01357 (28) 01
(54) CHAI (51) **09-01**
(22) 30.09.2008 (43) 25.12.2008
(71) **CÔNG TY CỔ PHẦN RƯỢU PHÚ LỄ (VN)**
81C Phan Đình Phùng, phường Phú Khương, thị xã Bến Tre, tỉnh Bến Tre
(72) Trần Anh Thụy (VN)
(74) Công ty TNHH Tư vấn sở hữu trí tuệ Việt (VIET IP CO.,LTD.)
(55)



1.1

1.2

1.3

1.4

1.5

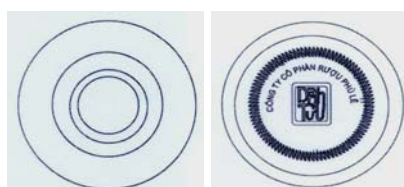

1.6

1.7

- (11) **13881**
(21) 3-2008-01358 (28) 01
(54) HỘP (51) **09-03**
(22) 30.09.2008 (43) 25.12.2008
(30) D2008-017554 08.07.2008 JP
(71) HISAMITSU PHARMACEUTICAL CO., INC. (JP)
408, Tashirodaikan-machi, Tosu-shi, Saga 841-0017 Japan
(72) Shigeo KUSUMI (JP), Nobuo TSUTSUMI (JP), Masakazu SHIGIISHI (JP)
(74) Công ty TNHH một thành viên Sở hữu trí tuệ VCCI (VCCI-IP CO.,LTD)
(55)



1.1

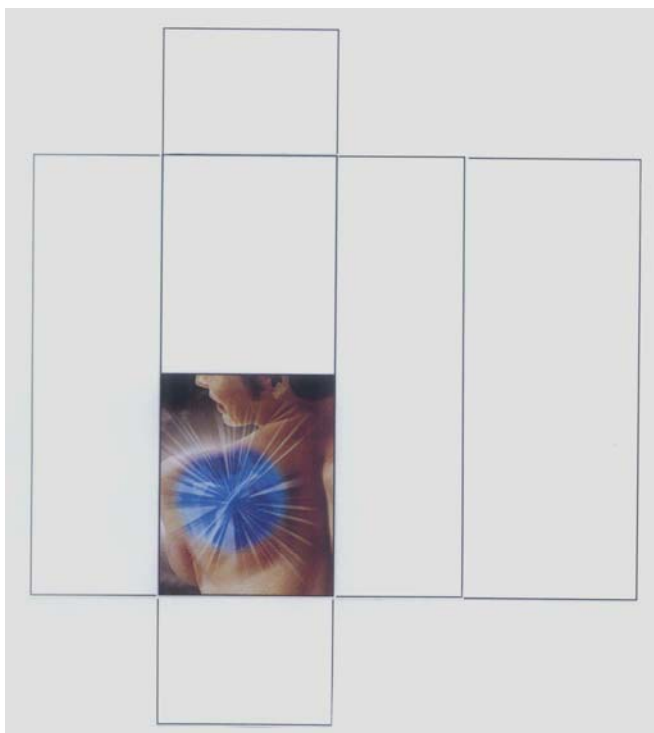

1.2

- (11) **13882**
(21) 3-2008-01359 (28) 01
(54) HỘP (51) **09-03**
(22) 30.09.2008 (43) 25.12.2008
(30) D2008-013788 30.05.2008 JP
(71) HISAMITSU PHARMACEUTICAL CO., INC. (JP)
408, Tashirodaikan-machi, Tosu-shi, Saga 841-0017 Japan
(72) Shigeo KUSUMI (JP), Homare KAMEKURA (JP)
(74) Công ty TNHH một thành viên Sở hữu trí tuệ VCCI (VCCI-IP CO.,LTD)
(55)

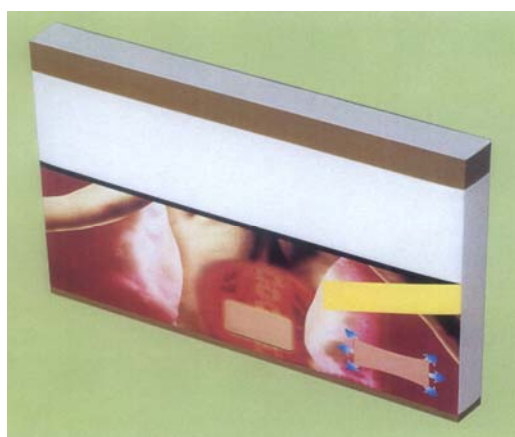

1.1

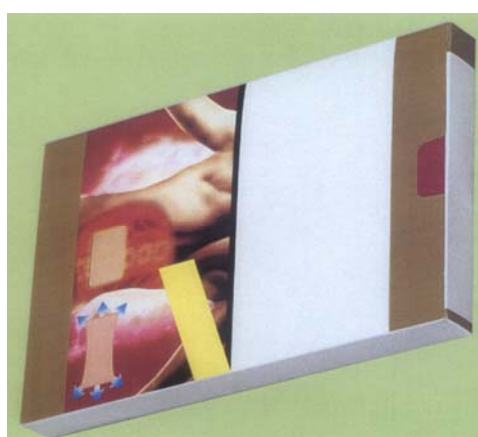

1.2

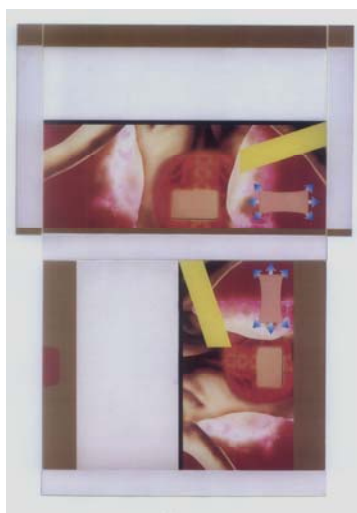

1.3

- (11) **13883**
(21) 3-2008-01360 (28) 01
(54) HỘP (51) **09-03**
(22) 30.09.2008 (43) 25.12.2008
(30) D2008-017829 10.07.2008 JP
(71) HISAMITSU PHARMACEUTICAL CO., INC. (JP)
408, Tashirodaikan-machi, Tosu-shi, Saga 841-0017 Japan
(72) Shigeo KUSUMI (JP)
(74) Công ty TNHH một thành viên Sở hữu trí tuệ VCCI (VCCI-IP CO.,LTD)
(55)

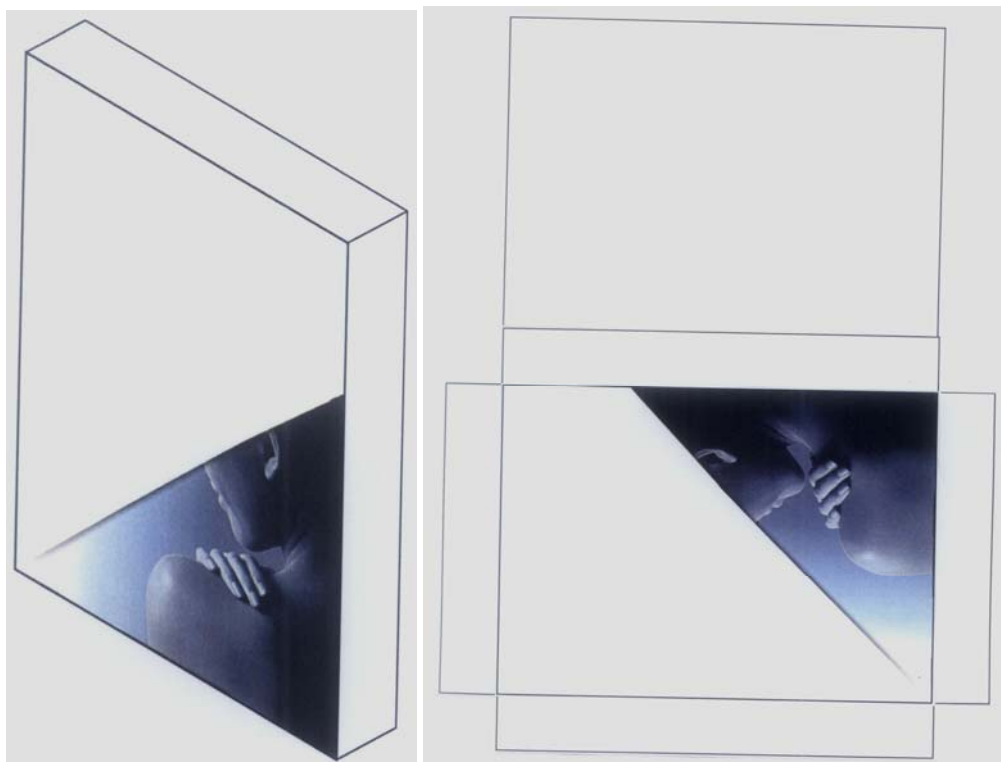

1.1

1.2

- (11) **13884**
(21) 3-2008-01363
(54) **HỘP ĐỰNG**
(22) 01.10.2008
(71) PERFETTI VAN MELLE S.p.A. (IT)
VIA XXV Aprile, 7, LAINATE, ITALY
(72) Ubaldo TRALDI (IT)
(74) Công ty TNHH Sở hữu trí tuệ WINCO (WINCO CO., LTD.)
(55)
- (28) 01
(51) **09-03**
(43) 25.12.2008

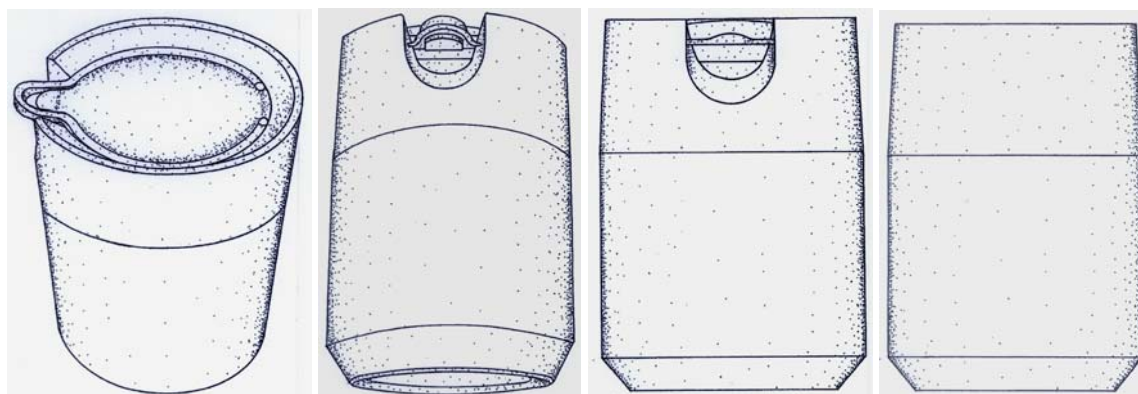

1.1

1.2

1.3

1.4

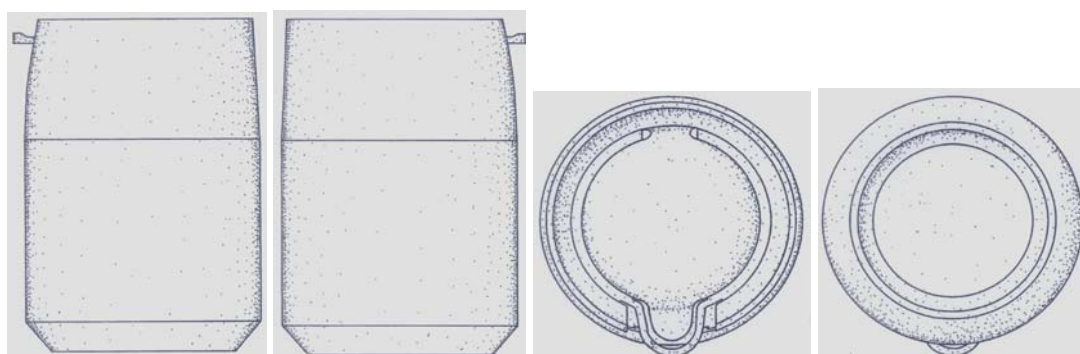

1.5

1.6

1.7

1.8

- (11) **13885**
(21) 3-2008-01364 (28) 01
(54) HỘP THUỐC (51) **09-03**
(22) 02.10.2008 (43) 25.12.2008
(71) CÔNG TY TRÁCH NHIỆM HỮU HẠN THƯƠNG MẠI DƯỢC PHẨM VIỆT HUNG (VN)
P206, K12, tập thể Bách Khoa, phường Bách Khoa, quận Hai Bà Trưng, thành phố Hà Nội
(72) Nguyễn Văn Vững (VN)
(74) Công ty TNHH Sở hữu trí tuệ Thảo Thọ Quyến (INVENCO)
(55)

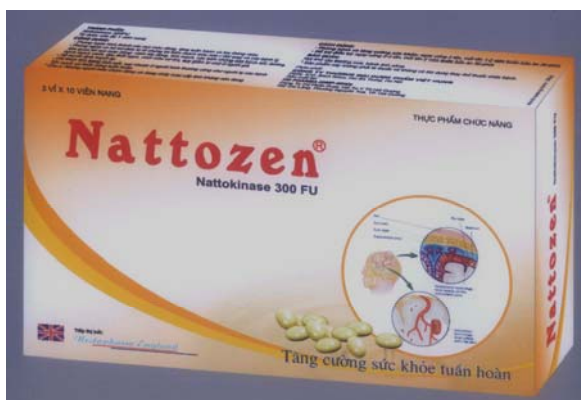

1.1



1.2

- (11) **13886**
(21) 3-2008-01365 (28) 01
(54) **HỘP ĐỰNG** (51) **09-03**
(22) 02.10.2008 (43) 25.12.2008
(71) **CÔNG TY TNHH DƯỢC PHẨM TÂN THỊNH (VN)**
Số 38, ngõ 308 đường Lê Trọng Tấn, phường Khương Mai, quận Thanh Xuân, thành phố Hà Nội
(72) Nguyễn Thu Hằng (VN)
(74) Công ty TNHH Vĩnh Phát và Liên danh (VIFA & ASSOCIATES CO.,LTD.)
(55)

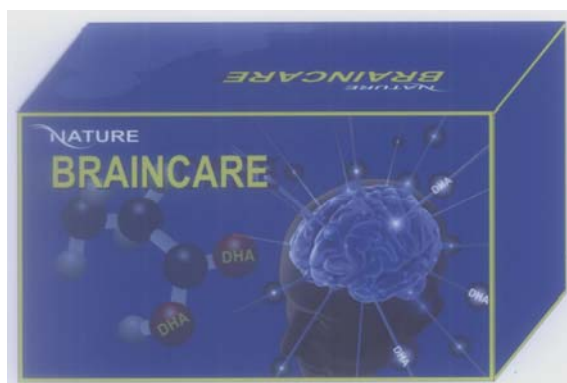

1.1

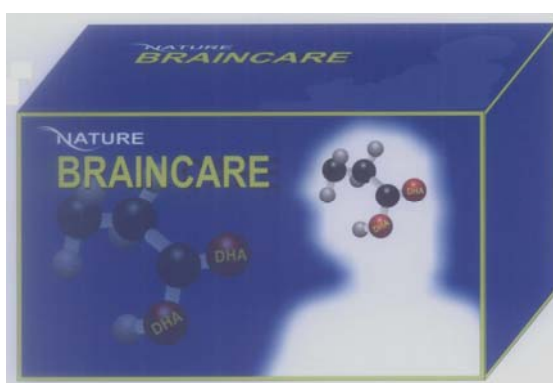

1.2

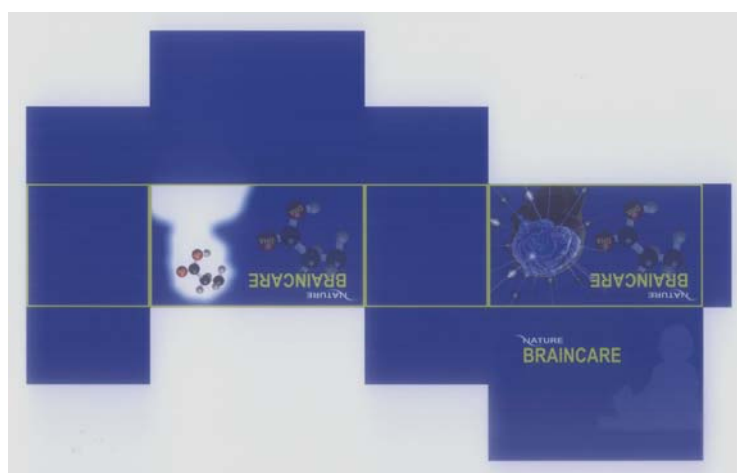

1.3

- (11) **13887**
(21) 3-2008-01366 (28) 01
(54) BAO GÓI BĂNG VỆ SINH (51) **09-05**
(22) 02.10.2008 (43) 25.12.2008
(71) CÔNG TY CỔ PHẦN DIANA (VN)
Khu công nghiệp Vĩnh Tuy, đường Lĩnh Nam, phường Vĩnh Hưng, quận Hoàng Mai,
thành phố Hà Nội
(72) Đỗ Anh Tú (VN)
(74) Công ty TNHH Sở hữu trí tuệ và Công nghệ Thủ đô (CAPITAL IP&T CO.LTD.)
(55)



1.1



1.2

- (11) **13888**
(21) 3-2008-01367 (28) 01
(54) BAO GÓI BĂNG VỆ SINH (51) **09-05**
(22) 02.10.2008 (43) 25.12.2008
(71) CÔNG TY CỔ PHẦN DIANA (VN)
Khu công nghiệp Vĩnh Tuy, đường Lĩnh Nam, phường Vĩnh Hưng, quận Hoàng Mai,
thành phố Hà Nội
(72) Đỗ Anh Tú (VN)
(74) Công ty TNHH Sở hữu trí tuệ và Công nghệ Thủ đô (CAPITAL IP&T CO.LTD.)
(55)



1.1



1.2

- (11) **13889**
(21) 3-2008-01368 (28) 02
(54) BAO GÓI TÃ GIẤY (51) **09-05**
(22) 02.10.2008 (43) 25.12.2008
(71) CÔNG TY CỔ PHẦN DIANA (VN)
Khu công nghiệp Vĩnh Tuy, đường Lĩnh Nam, phường Vĩnh Hưng, quận Hoàng Mai,
thành phố Hà Nội
(72) Đỗ Anh Tú (VN)
(74) Công ty TNHH Sở hữu trí tuệ và Công nghệ Thủ đô (CAPITAL IP&T CO.LTD.)
(55)



1.1



1.2



2.1



2.2

- (11) **13890**
(21) 3-2008-01370 (28) 01
(54) HỘP (51) **09-03**
(22) 02.10.2008 (43) 25.12.2008
(71) HỘ KINH DOANH CÁ THỂ ĐỒNG HỒ CÁT (VN)
41/1 Phạm Ngọc Thạch, phường 6, quận 3, TP. Hồ Chí Minh
(72) Lưu Thị Hồng Thảo (VN)
(74) Công ty Cổ phần Sở hữu công nghiệp INVESTIP (INVESTIP)
(55)



1.1

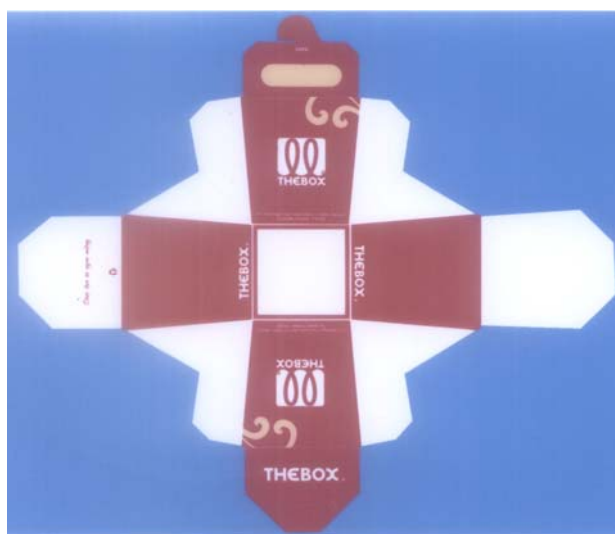

1.2

- (11) **13892**
(21) 3-2008-01373 (28) 01
(54) KHAY ĐỰNG TÔM (51) **09-04**
(22) 03.10.2008 (43) 25.12.2008
(71) CÔNG TY CỔ PHẦN HẢI SẢN BA MIỀN TƯ THUẬN (VN)
ấp 02, xã Tân Phong, huyện Giá Rai, tỉnh Bạc Liêu
(72) Đặng Hoàng Phương (VN)
(55)

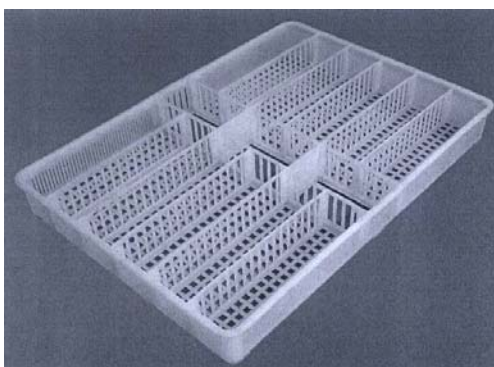

1.1

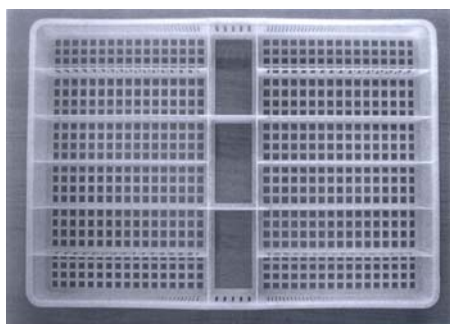

1.2

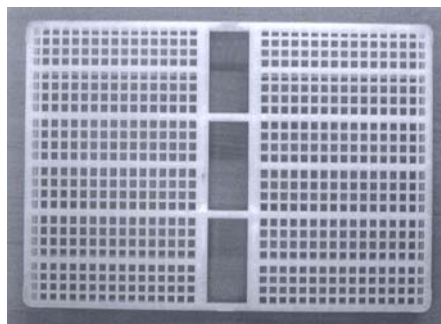

1.3

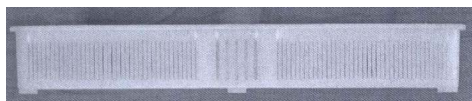

1.4

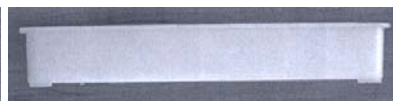

1.5

- (11) **13893**
 (21) 3-2008-01376 (28) 01
 (54) HỘP ĐỰNG THUỐC (51) **09-03**
 (22) 06.10.2008 (43) 25.12.2008
 (71) PHẠM VĂN THANH (VN)
 Xã Hồng Thuận, huyện Giao Thủy, tỉnh Nam Định
 (72) Phạm Văn Thanh (VN)
 (74) Công ty TNHH Sở hữu trí tuệ Bình Minh (SUNRISE IP CO.,LTD.)
 (55)



1.1



1.2

- (11) **13894**
(21) 3-2008-01377 (28) 01
(54) QUẦN ĐI MƯA (51) **02-02**
(22) 06.10.2008 (43) 25.12.2008
(71) CÔNG TY TRÁCH NHIỆM HỮU HẠN SẢN XUẤT NHỰA DƯƠNG GIA (VN)
Lô D11, cụm công nghiệp Nhị Xuân, xã Xuân Thới Sơn, huyện Hóc Môn, TP. Hồ Chí Minh
(72) Dương Tuấn Bình (VN)
(74) Công ty TNHH Sở hữu trí tuệ Thảo Thọ Quyến (INVENCO)
(55)



1.1

1.2

1.3

- (11) **13895**
(21) 3-2008-01378 (28) 01
(54) XE Ô TÔ (51) **12-08**
(22) 06.10.2008 (43) 25.12.2008
(71) TOYOTA JIDOSHA KABUSHIKI KAISHA (JP)
1, Toyota-cho, Toyota-shi, Aichi-ken 471-8571 Japan
(72) Shouichi FUJIYOSHI (JP), Noriyuki NAKAMURA (JP)
(74) Công ty TNHH một thành viên Sở hữu trí tuệ VCCI (VCCI-IP CO.,LTD)
(55)



1.1



1.2



1.3



1.4



1.5



1.6

- (11) **13896**
(21) 3-2008-01379 (28) 01
(54) KHUNG LƯỚI TẢN NHIỆT PHÍA (51) **12-16**
TRƯỚC CỦA Ô TÔ
(22) 06.10.2008 (43) 25.12.2008
(71) TOYOTA JIDOSHA KABUSHIKI KAISHA (JP)
1, Toyota-cho, Toyota-shi, Aichi-ken 471-8571 Japan
(72) Yoshiharu NAKAJIMA (JP), Kazuhiko HASUI (JP)
(74) Công ty TNHH một thành viên Sở hữu trí tuệ VCCI (VCCI-IP CO.,LTD)
(55)



1.1



1.2



1.3



1.4



1.5



1.6



1.7



1.8

- (11) **13897**
(21) 3-2008-01380 (28) 01
(54) KHUNG LƯỚI TẢN NHIỆT PHÍA (51) **12-16**
TRƯỚC CỦA Ô TÔ
(22) 06.10.2008 (43) 25.12.2008
(71) TOYOTA JIDOSHA KABUSHIKI KAISHA (JP)
1, Toyota-cho, Toyota-shi, Aichi-ken 471-8571 Japan
(72) Kazuhiko HASUI (JP)
(74) Công ty TNHH một thành viên Sở hữu trí tuệ VCCI (VCCI-IP CO.,LTD)
(55)



1.1



1.2



1.3



1.4



1.5



1.6

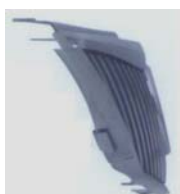

1.7



1.8

- (11) **13898**
(21) 3-2008-01381 (28) 01
(54) XE Ô TÔ (51) **12-08**
(22) 06.10.2008 (43) 25.12.2008
(71) TOYOTA JIDOSHA KABUSHIKI KAISHA (JP)
1, Toyota-cho, Toyota-shi, Aichi-ken 471-8571 Japan
(72) Jun TAKAHASHI (JP)
(74) Công ty TNHH một thành viên Sở hữu trí tuệ VCCI (VCCI-IP CO.,LTD)
(55)



1.1



1.2

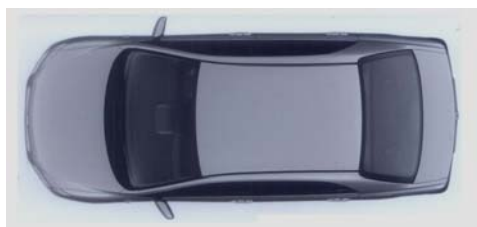

1.3



1.4



1.5



1.6

- (11) **13899**
(21) 3-2008-01382 (28) 01
(54) KHUNG LƯỚI TẢN NHIỆT PHÍA (51) **12-16**
TRƯỚC CỦA Ô TÔ
(22) 06.10.2008 (43) 25.12.2008
(71) TOYOTA JIDOSHA KABUSHIKI KAISHA (JP)
1, Toyota-cho, Toyota-shi, Aichi-ken 471-8571 Japan
(72) Noriyuki NAKAMURA (JP)
(74) Công ty TNHH một thành viên Sở hữu trí tuệ VCCI (VCCI-IP CO.,LTD)
(55)

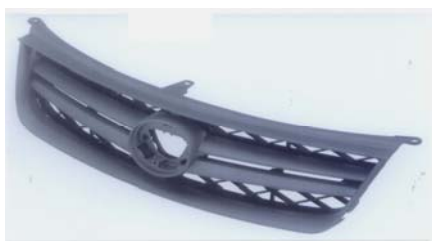

1.1



1.2



1.3



1.4



1.5



1.6



1.7



1.8

- (11) **13900**
(21) 3-2008-01383 (28) 01
(54) XE Ô TÔ (51) **12-08**
(22) 06.10.2008 (43) 25.12.2008
(71) TOYOTA JIDOSHA KABUSHIKI KAISHA (JP)
1, Toyota-cho, Toyota-shi, Aichi-ken 471-8571 Japan
(72) Jun TAKAHASHI (JP)
(74) Công ty TNHH một thành viên Sở hữu trí tuệ VCCI (VCCI-IP CO.,LTD)
(55)



1.1



1.2



1.3



1.4



1.5



1.6

- (11) **13901**
(21) 3-2008-01384 (28) 01
(54) BỘ ĐÈN PHÍA SAU CỦA Ô TÔ (51) **26-06**
(22) 06.10.2008 (43) 25.12.2008
(71) TOYOTA JIDOSHA KABUSHIKI KAISHA (JP)
1, Toyota-cho, Toyota-shi, Aichi-ken 471-8571 Japan
(72) Youhei KUSAMOTO (JP)
(74) Công ty TNHH một thành viên Sở hữu trí tuệ VCCI (VCCI-IP CO.,LTD)
(55)



1.1

1.2

1.3

1.4



1.5

1.6

1.7



1.8

CÔNG BÁO SỞ HỮU CÔNG NGHIỆP SỐ 249 TẬP A (12.2008)

- | | | | |
|------|--|------|--------------|
| (11) | 13902 | | |
| (21) | 3-2008-01392 | (28) | 01 |
| (54) | HỘP ĐỰNG CHÈ | (51) | 09-03 |
| (22) | 07.10.2008 | (43) | 25.12.2008 |
| (71) | TỔNG CÔNG TY CHÈ VIỆT NAM (VN)
Số 92, Võ Thị Sáu, quận Hai Bà Trưng, thành phố Hà Nội | | |
| (72) | Nguyễn Thiện Toàn (VN) | | |
| (74) | Công ty TNHH Sở hữu trí tuệ và Công nghệ Thủ đô (CAPITAL IP&T CO.LTD.) | | |
| (55) | | | |



1.1



1.2



1.3



1.4

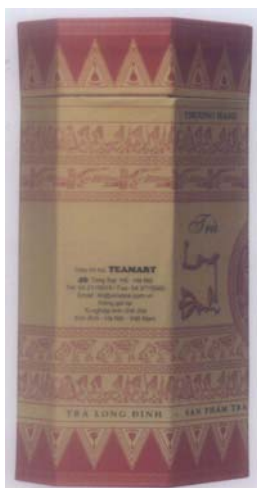

1.5



1.6



1.7



1.8

- | | | | |
|------|---|------|--------------|
| (11) | 13903 | | |
| (21) | 3-2008-01393 | (28) | 01 |
| (54) | HỘP | (51) | 09-03 |
| (22) | 07.10.2008 | (43) | 25.12.2008 |
| (71) | CÔNG TY CỔ PHẦN CÔNG NGHỆ GAM MA (VN)
Số 14/2A Kỳ Đồng, phường 9, quận 3, TP. Hồ Chí Minh | | |
| (72) | Nguyễn Tường Linh (VN) | | |
| (74) | Công ty TNHH Tầm nhìn và Liên danh (VISION & ASSOCIATES CO.LTD.) | | |
| (55) | | | |



1.1



1.2

- (11) **13904**
(21) 3-2008-01399
(54) KHỐI TRANG TRÍ
(22) 08.10.2008
(71) CÔNG TY TIÊN SƠN THANH HOÁ (VN)
Số 9 khu công nghiệp Bắc Bỉm Sơn, thị xã Bỉm Sơn, tỉnh Thanh Hóa
(72) Trịnh Xuân Lâm (VN)
(55)
- (28) 01
(51) **11-02**
(43) 25.12.2008



1.1

1.2

1.3

1.4

1.5

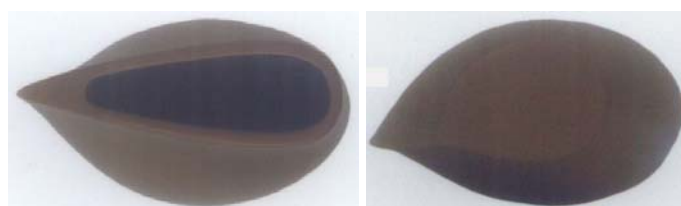

1.6

1.7

CÔNG BÁO SỞ HỮU CÔNG NGHIỆP SỐ 249 TẬP A (12.2008)

- | | | | |
|------|--|------|--------------|
| (11) | 13905 | | |
| (21) | 3-2008-01400 | (28) | 01 |
| (54) | NHÃN SẢN PHẨM | (51) | 19-08 |
| (22) | 08.10.2008 | (43) | 25.12.2008 |
| (71) | CÔNG TY TNHH RƯỢU VÀ NƯỚC GIẢI KHÁT ANH ĐÀO (VN)
Khu công nghiệp Phú Diễn, Từ Liêm, thành phố Hà Nội | | |
| (72) | Vũ Mạnh Hào (VN) | | |
| (74) | Công ty TNHH Tư vấn Nhiệt tâm và Cộng sự (NT & PARTNERS CO.,LTD.) | | |
| (55) | | | |



- (11) **13906**
(21) 3-2008-01401 (28) 01
(54) XE TẢI (51) **12-08**
(22) 08.10.2008 (43) 25.12.2008
(30) 200830113836.8 10.04.2008 CN
(71) SAIC-IVECO HONGYAN COMMERCIAL VEHICLE CO., LTD. (CN)
No. B04 block of Huangmaoping in economic development park of Economic and
Technical development Zone, Chongqing 401122, P.R. China
(72) WEI, Zhongxuan (CN), LONG, Quan (CN), ZHU, Yi (CN)
(74) Công ty TNHH Sở hữu trí tuệ WINCO (WINCO CO., LTD.)
(55)

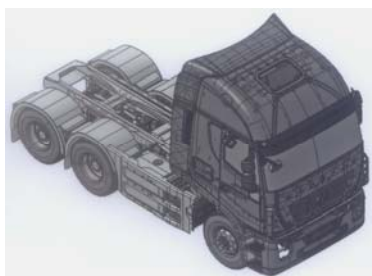

1.1

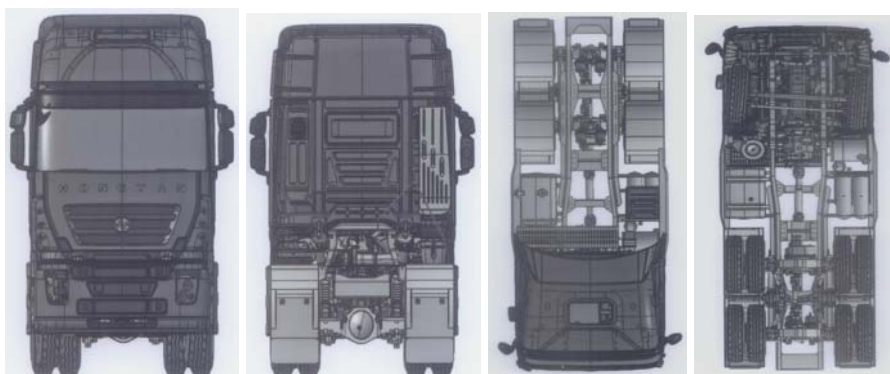

1.2

1.3

1.4

1.5



1.6

1.7

- (11) **13907**
(21) 3-2008-01402 (28) 01
(54) LOA (51) **14-01**
(22) 08.10.2008 (43) 25.12.2008
(71) DOANH NGHIỆP TƯ NHÂN VĂN HỒ (VN)
88 Nguyễn Trung Trực, phường 2, thị xã Tân An, tỉnh Long An
(72) Nguyễn Văn Hồ (VN)
(74) Công ty TNHH Sở hữu trí tuệ WINCO (WINCO CO., LTD.)
(55)

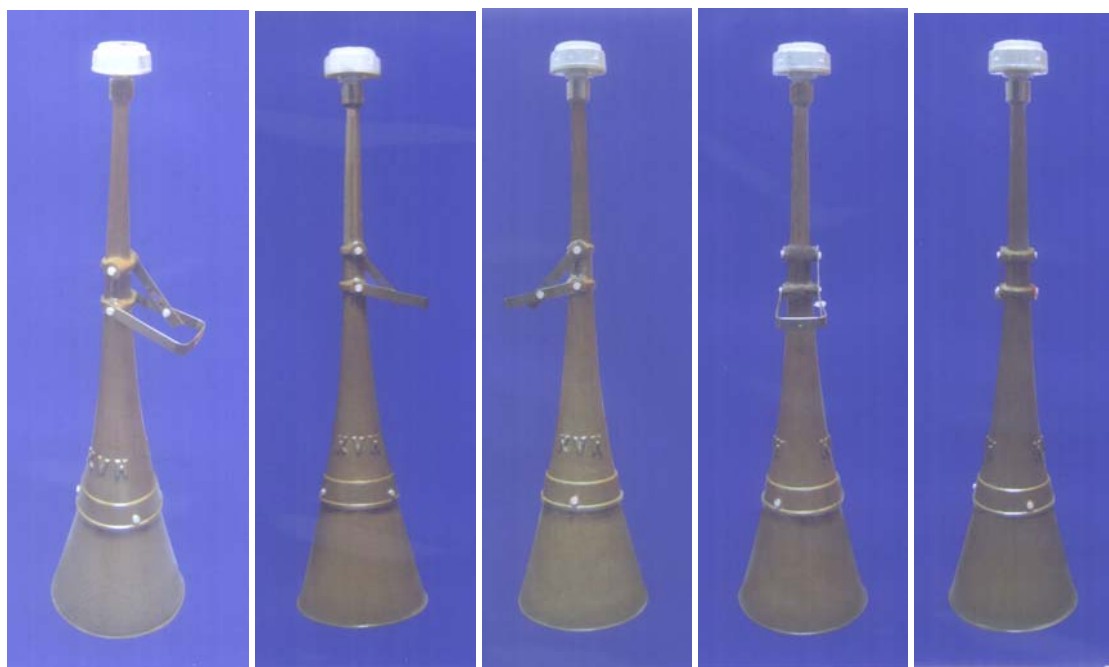

1.1

1.2

1.3

1.4

1.5

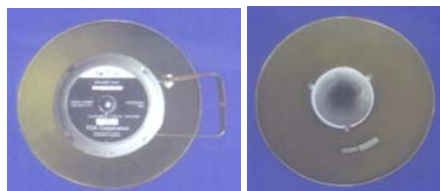

1.6

1.7

- (11) **13908**
(21) 3-2008-01405 (28) 01
(54) HỘP ĐỰNG RƯỢU (51) **09-03**
(22) 09.10.2008 (43) 25.12.2008
(71) CÔNG TY CỔ PHẦN RƯỢU HÀ NỘI (VN)
Số 28 ngách 481/69 Đường Ngọc Lâm, tổ 1 phường Thượng Thanh, quận Long Biên,
thành phố Hà Nội
(72) Đỗ Thị Thanh Bình (VN)
(55)



1.1



1.2

- (11) **13909**
(21) 3-2008-01406 (28) 01
(54) HỘP ĐỰNG RƯỢU (51) **09-03**
(22) 09.10.2008 (43) 25.12.2008
(71) CÔNG TY CỔ PHẦN RƯỢU HÀ NỘI (VN)
Số 28 ngách 481/69 Đường Ngọc Lâm, tổ 1 phường Thượng Thanh, quận Long Biên,
thành phố Hà Nội
(72) Đỗ Thị Thanh Bình (VN)
(55)



1.1



1.2

- (11) **13910**
(21) 3-2008-01407 (28) 01
(54) HỘP ĐUNG RƯỢU (51) **09-03**
(22) 09.10.2008 (43) 25.12.2008
(71) CÔNG TY CỔ PHẦN RƯỢU HÀ NỘI (VN)
Số 28 ngách 481/69 Đường Ngọc Lâm, tổ 1 phường Thượng Thanh, quận Long Biên,
thành phố Hà Nội
(72) Đỗ Thị Thanh Bình (VN)
(55)



1.1



1.2

- (11) **13911**
(21) 3-2008-01410 (28) 01
(54) BỘ DAO CẠO CẦM TAY (51) **28-03**
(22) 10.10.2008 (43) 25.12.2008
(30) 000919147 17.04.2008 EM
(71) SOCIETE BIC (FR)
14 rue Jeanne D'Asnières, 92 110 Clichy, France
(72) Ioannis Psimadas (GR), Ioannis Bozikis (GR), Spiros Gratsias (GR)
(74) Văn phòng luật sư Phạm và Liên danh (PHAM & ASSOCIATES)
(55)

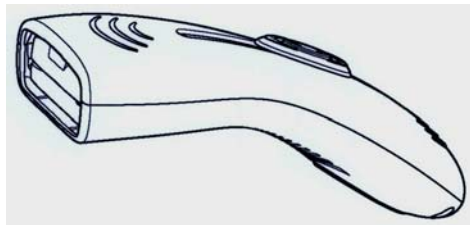

1.1

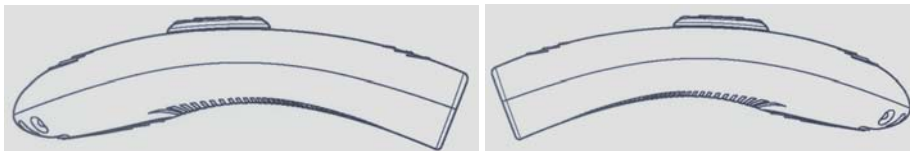

1.2

1.3

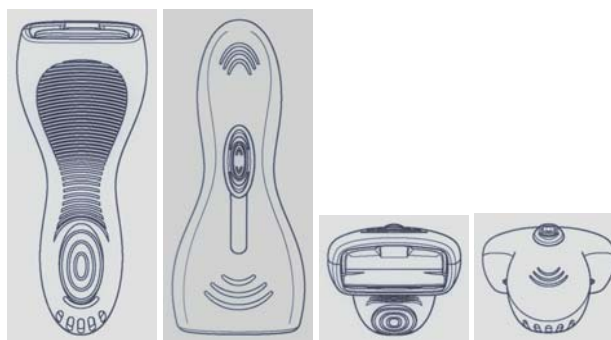

1.4

1.5

1.6

1.7

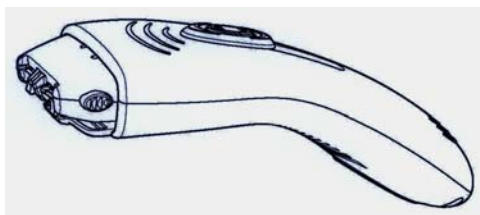

1.8



1.9



1.10



1.11



1.12



1.13



1.14

- (11) **13912**
(21) 3-2008-01411 (28) 01
(54) MŨ BẢO HIỂM (51) **02-03**
(22) 10.10.2008 (43) 25.12.2008
(71) CÔNG TY TNHH THƯƠNG MẠI - DỊCH VỤ - SẢN XUẤT NGUYÊN BẢO TÍN (VN)
216/6 Phú Thọ Hòa, phường Phú Thọ Hoà, quận Tân Phú, TP. Hồ Chí Minh
(72) Huỳnh Văn ý (VN)
(55)



1.1

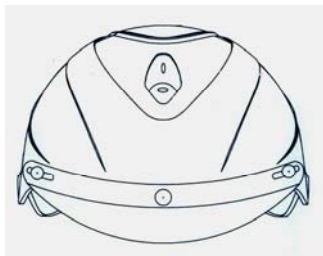

1.2

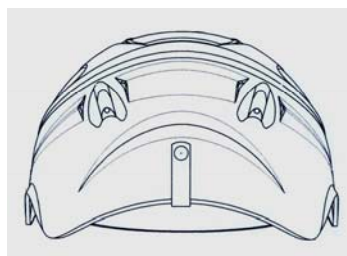

1.3

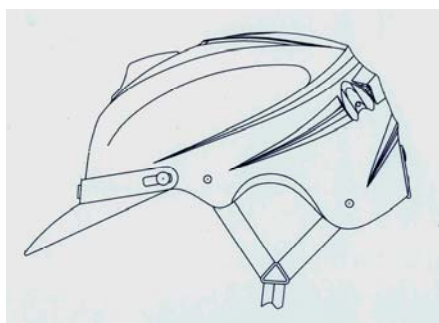

1.4

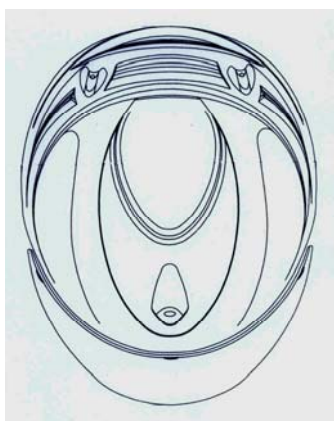

1.5

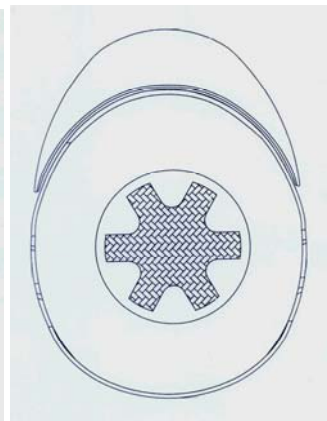

1.6

- (11) **13913**
(21) 3-2008-01412
(54) MŨ BẢO HIỂM
(22) 10.10.2008
(71) CÔNG TY TNHH THƯƠNG MẠI - DỊCH VỤ - SẢN XUẤT NGUYÊN BẢO TÍN (VN)
216/6 Phú Thọ Hòa, phường Phú Thọ Hoà, quận Tân Phú, TP. Hồ Chí Minh
(72) Huỳnh Văn ý (VN)
(55)
(28) 01
(51) **02-03**
(43) 25.12.2008

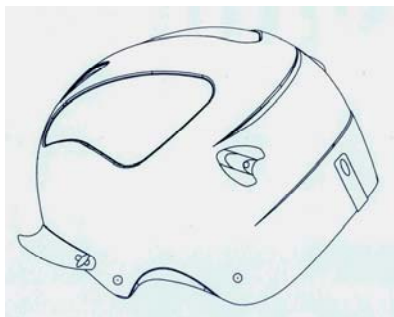

1.1

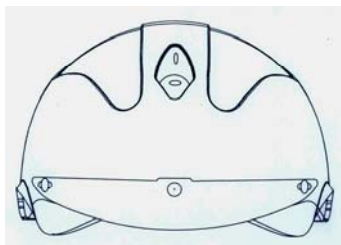

1.2

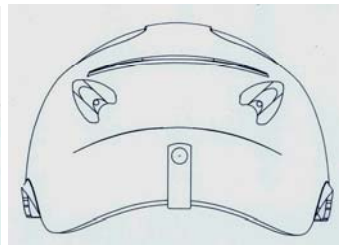

1.3

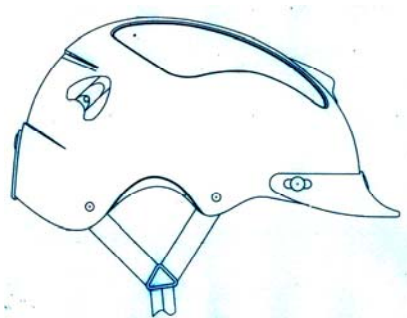

1.4



1.5

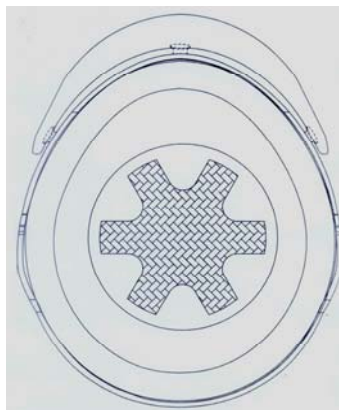

1.6

- (11) **13914**
(21) 3-2008-01413 (28) 01
(54) CHAI (51) **09-01**
(22) 10.10.2008 (43) 25.12.2008
(71) CÔNG TY TNHH RƯỢU VÀ NƯỚC GIẢI KHÁT ANH ĐÀO (VN)
Khu công nghiệp Phú Diễn, Từ Liêm, thành phố Hà Nội
(72) Vũ Mạnh Hào (VN)
(74) Công ty TNHH Tư vấn Nhiệt tâm và Cộng sự (NT & PARTNERS CO.,LTD.)
(55)



1.1

1.2

1.3

1.4

1.5

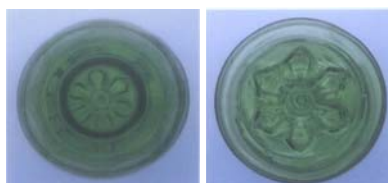

1.6

1.7

- (11) **13915**
(21) 3-2008-01414 (28) 01
(54) HỘP ĐỰNG SẢN PHẨM (51) **09-03**
(22) 10.10.2008 (43) 25.12.2008
(71) CÔNG TY TNHH TRANG THIẾT BỊ Y TẾ THỜI THANH BÌNH (VN)
314/1 Ba Đình, phường 10, quận 8, TP. Hồ Chí Minh
(72) Nguyễn Tâm Thái (VN)
(74) Công ty TNHH Sở hữu trí tuệ WINCO (WINCO CO., LTD.)
(55)



1.1



1.2

- (11) **13916**
(21) 3-2008-01415 (28) 02
(54) HỘP ĐỰNG SẢN PHẨM (51) **09-03**
(22) 10.10.2008 (43) 25.12.2008
(71) CÔNG TY TNHH TRANG THIẾT BỊ Y TẾ THỜI THANH BÌNH (VN)
314/1 Ba Đình, phường 10, quận 8, TP. Hồ Chí Minh
(72) Nguyễn Tâm Thái (VN)
(74) Công ty TNHH Sở hữu trí tuệ WINCO (WINCO CO., LTD.)
(55)



1.1



1.2



2.1



2.2

- (11) **13917**
(21) 3-2008-01416 (28) 01
(54) HỘP ĐỰNG RƯỢU (51) **09-03**
(22) 10.10.2008 (43) 25.12.2008
(71) CÔNG TY CỔ PHẦN RƯỢU HÀ NỘI (VN)
Số 28 ngách 481/69 đường Ngọc Lâm, tổ 1 phường Thượng Thanh, quận Long Biên,
thành phố Hà Nội
(72) Đỗ Thị Thanh Bình (VN)
(55)



1.1



1.2

- (11) **13918**
(21) 3-2008-01417 (28) 01
(54) HỘP ĐUNG RƯỢU (51) **09-03**
(22) 10.10.2008 (43) 25.12.2008
(71) CÔNG TY CỔ PHẦN RƯỢU HÀ NỘI (VN)
Số 28 ngách 481/69 đường Ngọc lâm, tổ 1 phường Thượng Thanh, quận Long Biên,
thành phố Hà Nội
(72) Đỗ Thị Thanh Bình (VN)
(55)



1.1



1.2

- (11) **13919**
(21) 3-2008-01418 (28) 01
(54) CHAI ĐỰNG NƯỚC MẮM (51) **09-01**
(22) 10.10.2008 (43) 25.12.2008
(71) NGUYỄN HỮU NGUYÊN (VN)
Khách sạn Vạn Hoa, tổ 9, khu 9, phường Bãi Cháy, thành phố Hạ Long, tỉnh Quảng Ninh
(72) Nguyễn Hữu Nguyên (VN)
(74) Công ty TNHH Sở hữu trí tuệ HA VIP (HAVIP CO., LTD.)
(55)



1.1

1.2

1.3

1.4

1.5



1.6

1.7

1.8

- (11) **13920**
(21) 3-2008-01422 (28) 01
(54) CHAI (51) **09-02**
(22) 13.10.2008 (43) 25.12.2008
(71) CÔNG TY TNHH THƯƠNG MẠI THUẬN MỸ (VN)
28/75 Lương Thế Vinh, phường Tân Thới Hòa, quận Tân Phú, TP. Hồ Chí Minh
(72) Nguyễn Thị Nhạn (VN)
(74) DNTN Dịch vụ thương mại và sở hữu công nghiệp Song Ngọc (I.P.T.S.)
(55)



1.1

1.2

1.3

1.4

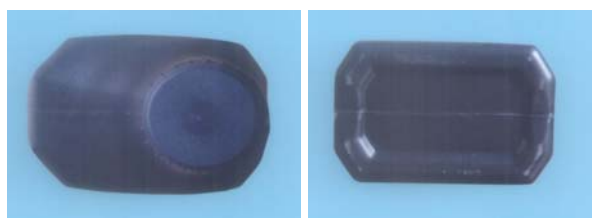

1.5

1.6

- (11) **13921**
(21) 3-2008-01423 (28) 02
(54) GHẾ (51) **06-01**
(22) 13.10.2008 (43) 25.12.2008
(71) CÔNG TY CỔ PHẦN CAO SU SÀI GÒN - KYMDAN (VN)
28 Bình Thới, phường 14, quận 11, TP. Hồ Chí Minh
(72) Nguyễn Hữu Trí (VN)
(74) Công ty TNHH Sở hữu trí tuệ Thảo Thọ Quyến (INVENCO)
(55)



1.1



1.2



1.3



1.4



1.5



2.1

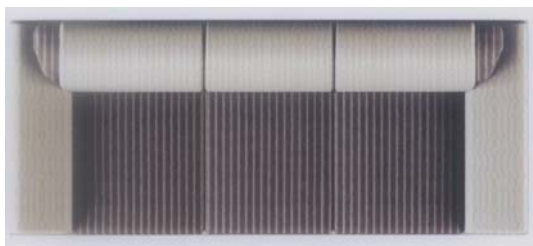

2.2

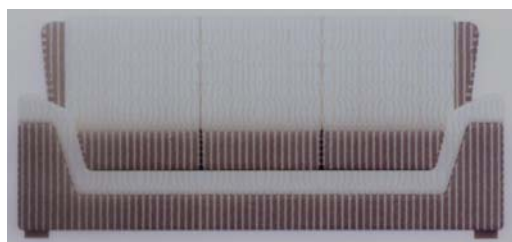

2.3



2.4



2.5

- (11) **13922**
(21) 3-2008-01424 (28) 01
(54) BÀN (51) **06-03**
(22) 13.10.2008 (43) 25.12.2008
(71) CÔNG TY CỔ PHẦN CAO SU SÀI GÒN - KYMDAN (VN)
28 Bình Thới, phường 14, quận 11, TP. Hồ Chí Minh
(72) Nguyễn Hữu Trí (VN)
(74) Công ty TNHH Sở hữu trí tuệ Thảo Thọ Quyến (INVENCO)
(55)



1.1

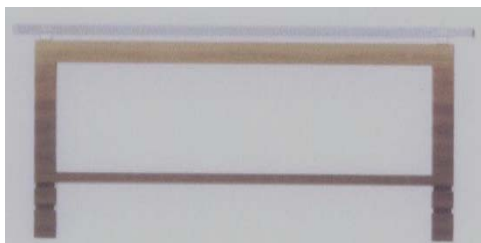

1.2

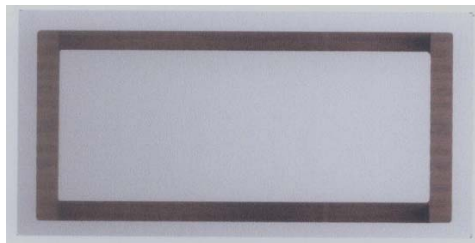

1.3



1.4

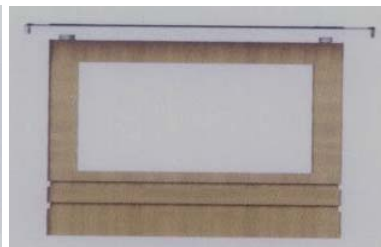

1.5

- (11) **13923**
(21) 3-2008-01425 (28) 01
(54) XE Ô TÔ (51) **12-08**
(22) 13.10.2008 (43) 25.12.2008
(71) CHONGQING CHANGAN AUTOMOBILE CO., LTD. (CN)
No. 260 Jianxin Donglu, Jiangbei District, Chongqing 400023, P.R. China
(72) LIU, Changliang (CN), YE, Lijuan (CN), DENG, Xin (CN), CHEN, Zheng (CN),
LIANG, Lin (CN)
(74) Công ty TNHH Sở hữu trí tuệ WINCO (WINCO CO., LTD.)
(55)



1.1



1.2



1.3



1.4



1.5



1.6



1.7

- (11) **13924**
(21) 3-2008-01426 (28) 01
(54) NHÃN SẢN PHẨM (51) **19-08**
(22) 13.10.2008 (43) 25.12.2008
(71) CÔNG TY TRÁCH NHIỆM HỮU HẠN RUSSIAN SOUTH EAST (VN)
Cụm công nghiệp Quán Trữ, Kiến An, thành phố Hải Phòng
(72) Bernadzikovskiy Igor (RU)
(74) Công ty TNHH Nghiên cứu và Tư vấn chuyển giao công nghệ và đầu tư (CONCETTI)
(55)



1.1



1.2

- (11) **13925**
(21) 3-2008-01430
(54) BÀN CHẢI
(22) 14.10.2008
(71) CƠ SỞ LƯU BẢO CHÂU (VN)
300 Gia Phú, phường 3, quận 6, TP. Hồ Chí Minh
(72) Lưu Cẩm Thành (VN)
(74) Công ty TNHH Sở hữu trí tuệ Thảo Thọ Quyến (INVENCO)
(55)
- (28) 01
(51) **04-01**
(43) 25.12.2008



1.1

1.2

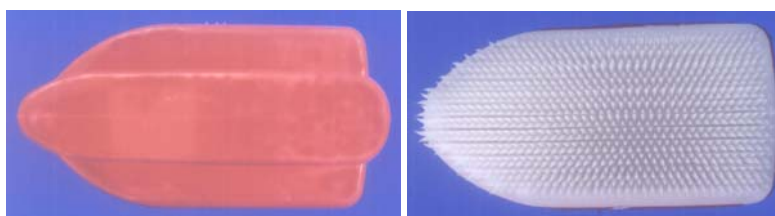

1.3

1.4

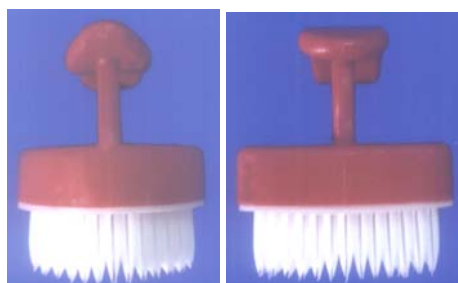

1.5

1.6

- (11) **13926**
(21) 3-2008-01434 (28) 01
(54) GIƯỜNG NGỦ (51) **06-02**
(22) 16.10.2008 (43) 25.12.2008
(71) CÔNG TY CỔ PHẦN CAO SU SÀI GÒN - KYMDAN (VN)
28 Bình Thới, phường 14, quận 11, TP. Hồ Chí Minh
(72) Nguyễn Hữu Trí (VN)
(74) Công ty TNHH Sở hữu trí tuệ Thảo Thọ Quyến (INVENCO)
(55)



1.1



1.2



1.3



1.4



1.5

- (11) **13927**
(21) 3-2008-01435 (28) 01
(54) GIƯỜNG NGỦ (51) **06-02**
(22) 16.10.2008 (43) 25.12.2008
(71) CÔNG TY CỔ PHẦN CAO SU SÀI GÒN - KYMDAN (VN)
28 Bình Thới, phường 14, quận 11, TP. Hồ Chí Minh
(72) Nguyễn Hữu Trí (VN)
(74) Công ty TNHH Sở hữu trí tuệ Thảo Thọ Quyến (INVENCO)
(55)



1.1



1.2



1.3

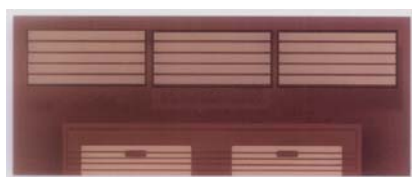

1.4



1.5



1.6

- (11) **13928**
(21) 3-2008-01436 (28) 01
(54) TỦ (51) **06-04**
(22) 16.10.2008 (43) 25.12.2008
(71) CÔNG TY CỔ PHẦN CAO SU SÀI GÒN - KYMDAN (VN)
28 Bình Thới, phường 14, quận 11, TP. Hồ Chí Minh
(72) Nguyễn Hữu Trí (VN)
(74) Công ty TNHH Sở hữu trí tuệ Thảo Thọ Quyến (INVENCO)
(55)



1.1

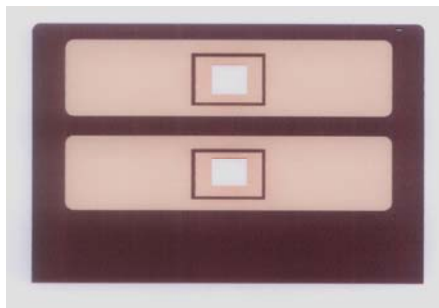

1.2



1.3

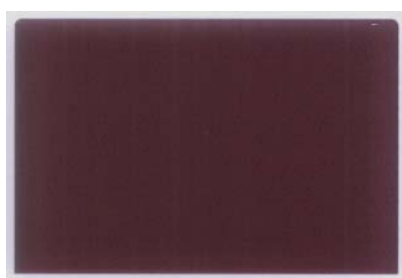

1.4



1.5



1.6

- (11) **13929**
(21) 3-2008-01438 (28) 01
(54) TỦ (51) **06-04**
(22) 16.10.2008 (43) 25.12.2008
(71) CÔNG TY CỔ PHẦN CAO SU SÀI GÒN - KYMDAN (VN)
28 Bình Thới, phường 14, quận 11, TP. Hồ Chí Minh
(72) Nguyễn Hữu Trí (VN)
(74) Công ty TNHH Sở hữu trí tuệ Thảo Thọ Quyến (INVENCO)
(55)

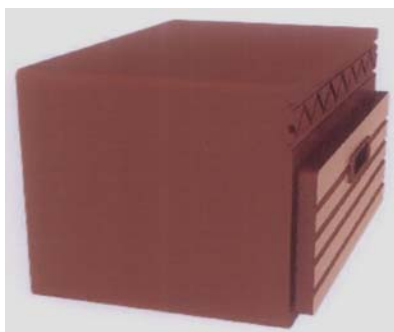

1.1



1.2



1.3



1.4



1.5



1.6

- (11) **13930**
(21) 3-2008-01440 (28) 01
(54) LỚP Ô TÔ (51) **12-15**
(22) 20.10.2008 (43) 25.12.2008
(30) 30-2008-0023866 04.06.2008 KR
(71) KUMHO TIRE CO., LNC. (KR)
555, Sochon-dong, Gwangsan-gu, Gwangju 506-711, Republic of Korea
(72) LEE, Si On (KR)
(74) Công ty TNHH Trần Hữu Nam và Đồng sự (TRAN H.N & ASS.)
(55)

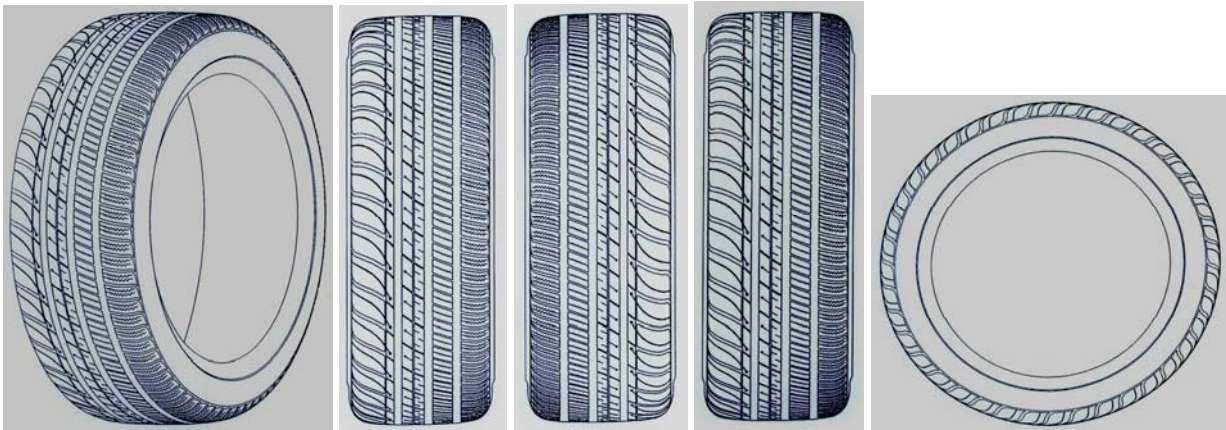

1.1

1.2

1.3

1.4

1.5

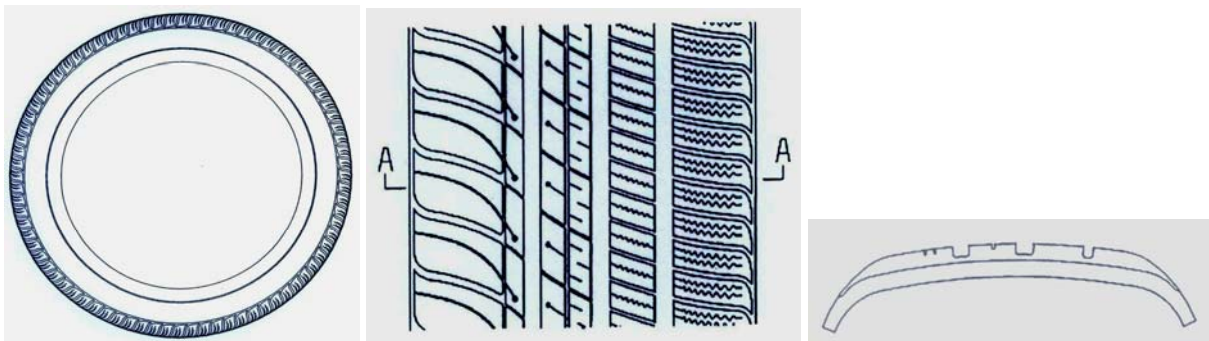

1.6

1.7

1.8

- (11) **13931**
(21) 3-2008-01448 (28) 01
(54) HỘP (51) **09-03**
(22) 22.10.2008 (43) 25.12.2008
(71) ARIES FRESH PTE. LTD. (SG)
Blk 10, Wholesale Centre, #01- 417 Singapore 110010
(72) ONG KHIM HWA (SG)
(74) Công ty Luật TNHH V.N.I.P (V.N.I.P LAW FIRM)
(55)



1.1



1.2

- (11) **13932**
(21) 3-2008-01453 (28) 01
(54) **HỘP ĐỰNG SẢN PHẨM** (51) **09-03**
(22) 24.10.2008 (43) 25.12.2008
(71) **CÔNG TY TNHH HOÀNG HƯƠNG (VN)**
Số 6 ngõ 111, phố Láng Hạ, quận Đống Đa, thành phố Hà Nội
(72) **Đình Thị Chì (VN)**
(74) Công ty TNHH Sở hữu trí tuệ WINCO (WINCO CO., LTD.)
(55)



1.1

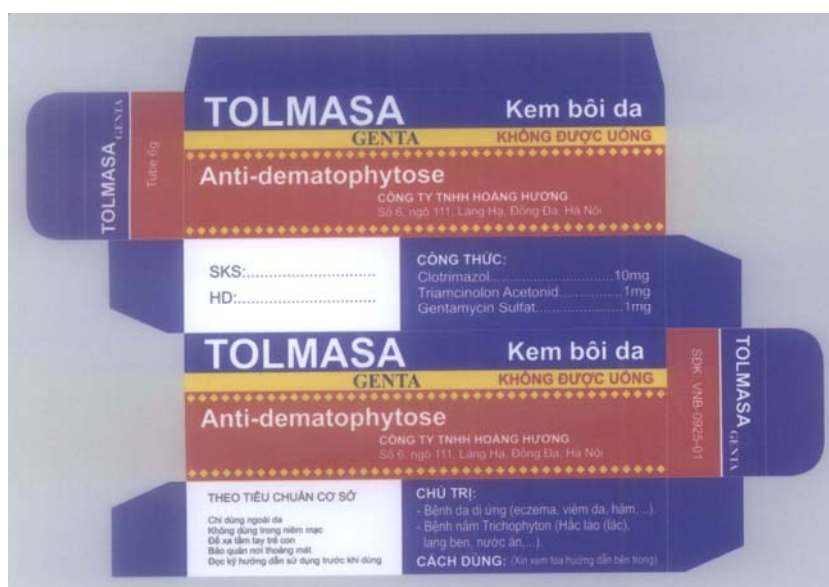

1.2

- (11) **13933**
(21) 3-2008-01458 (28) 01
(54) GIẤY GÓI KẸO (51) **09-05**
(22) 24.10.2008 (43) 25.12.2008
(71) CÔNG TY CỔ PHẦN BÁNH KẸO NHẬT MỸ (VN)
Xóm Quyết Tiến, xã La Phù, huyện Hoài Đức, Hà Nội
(72) Ngô Văn Sơn (VN)
(74) Công ty TNHH Sở hữu trí tuệ và Công nghệ Thủ đô (CAPITAL IP&T CO.LTD.)
(55)



1.1



1.2

- (11) **13934**
(21) 3-2008-01462
(54) KÉO
(22) 27.10.2008
(71) ĐOÀN VĂN TIẾN (VN)
61/17/14A Đất Thánh, phường 6, quận Tân Bình, TP. Hồ Chí Minh
(72) Đoàn Văn Tiến (VN)
(74) DNTN Dịch vụ thương mại và sở hữu công nghiệp Song Ngọc (I.P.T.S.)
(55)
- (28) 01
(51) **08-03**
(43) 25.12.2008



1.1

1.2

1.3

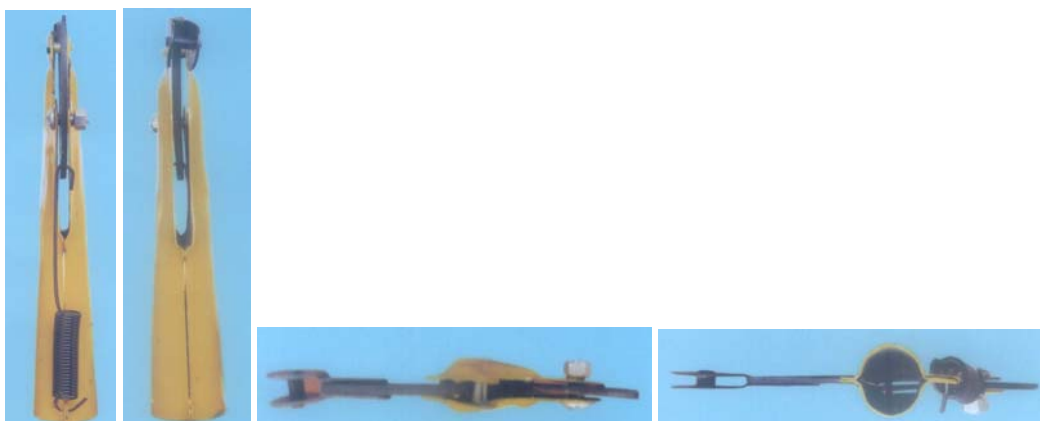

1.4

1.5

1.6

1.7