

PHẦN III

ĐƠN YÊU CẦU CẤP BẰNG ĐỘC QUYỀN KIỂU KIỂU DÁNG CÔNG NGHIỆP

- (11) **12975**
(21) 3-2007-00876 (28) 01
(54) HỘP ĐÈN QUẢNG CÁO (51) **20-03**
(22) 09.07.2007 (43) 25.06.2008
(71) CÔNG TY TNHH PHÁT TRIỂN THÀNH PHỐ (VN)
81A Lê Văn Hưu, quận Hai Bà Trưng, thành phố Hà Nội
(72) Cheung Chung Ping, Gary (GB)
(55)

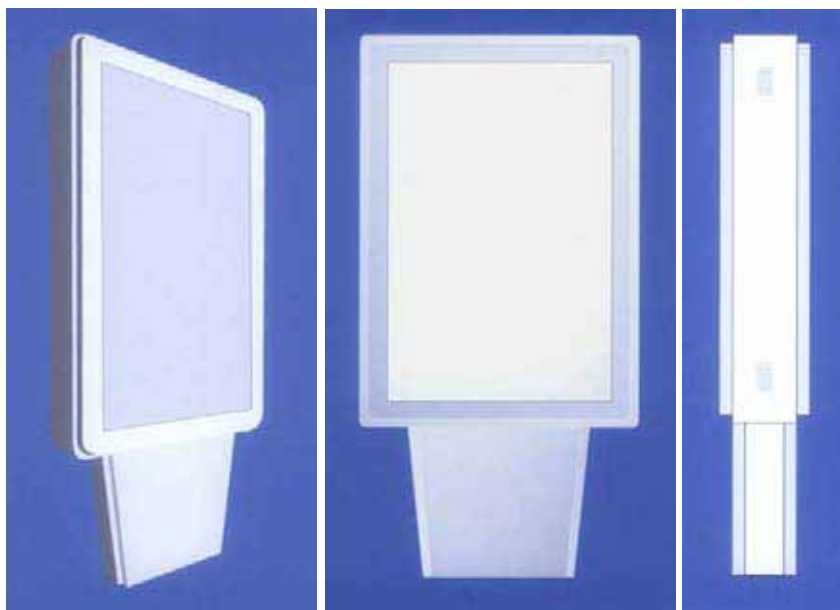

1.1

1.2

1.3

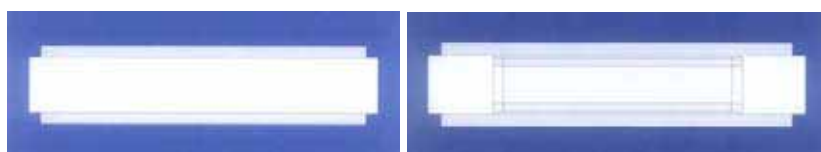

1.4

1.5

- (11) **12976**
(21) 3-2007-01626 (28) 01
(54) BÀN (51) **06-03**
(22) 26.11.2007 (43) 25.06.2008
(71) CÔNG TY CỔ PHẦN CAO SU SÀI GÒN - KYMDAN (VN)
28 Bình Thới, phường 14, quận 11, TP. Hồ Chí Minh
(72) Nguyễn Hữu Trí (VN)
(74) Công ty TNHH Sở hữu trí tuệ Thảo Thọ Quyến (INVENCO)
(55)



1.1



1.2



1.3



1.4



1.5

- (11) **12977**
(21) 3-2007-01655 (28) 01
(54) BÀN XẾP (51) **06-03**
(22) 27.11.2007 (43) 25.06.2008
(30) 29/281224 19.06.2007 US
(71) MORRIS LNVESTMENTS, LLC (US)
316 Corporate Place, Chattanooga, Tennessee 37419, United States of America
(72) Suzanne Morris (US), Glenn H. Morris JR. (US)
(74) Công ty TNHH Sở hữu trí tuệ WINCO (WINCO CO., LTD.)
(55)



1.1

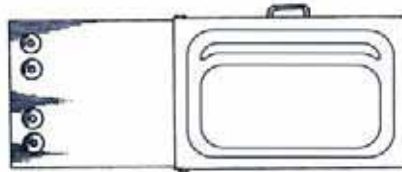

1.2



1.3



1.4

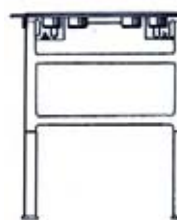

1.5

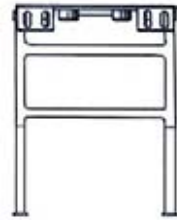

1.6



1.7

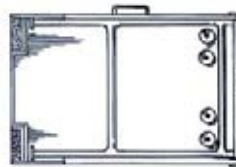

1.8



1.9

- (11) **12978**
(21) 3-2007-01759 (28) 01
(54) CHAI (51) **09-01**
(22) 14.12.2007 (43) 25.06.2008
(71) CÔNG TY TNHH CHẾ BIẾN NƯỚC CHẤM MEKONG (VN)
Tỉnh lộ 10, xã Đức Hòa Hạ, huyện Đức Hòa, tỉnh Long An
(72) Phan Bảo Duy (VN)
(74) Văn phòng luật sư Phạm và Liên danh (PHAM & ASSOCIATES)
(55)

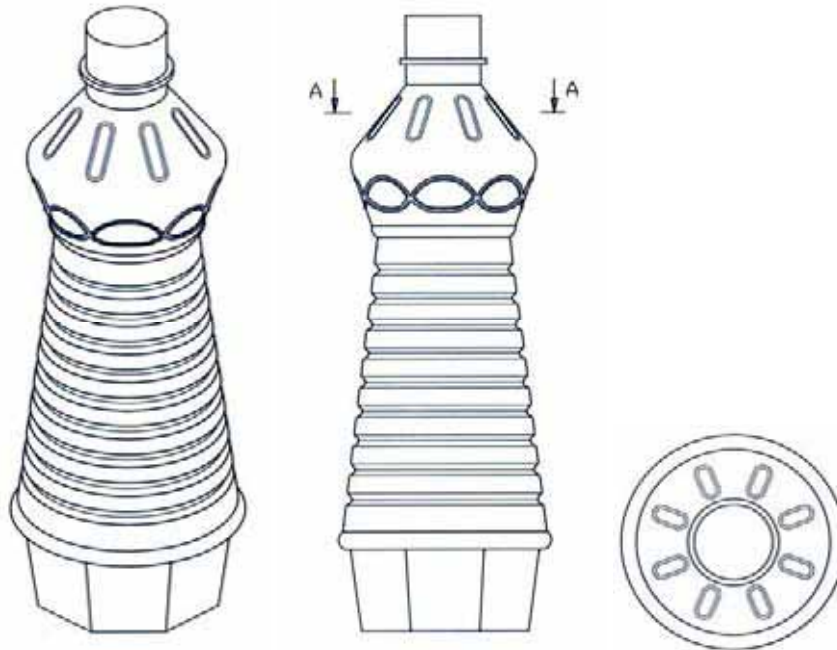

1.1

1.2

1.3

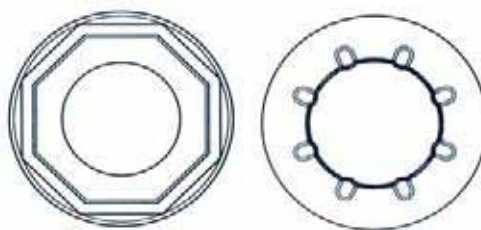

1.4

1.5

- (11) **12979**
(21) 3-2007-01806 (28) 01
(54) ĐẦU GẬY CHƠI GÔN (51) **21-02**
(22) 18.12.2007 (43) 25.06.2008
(30) 29/282628 25.07.2007 US
(71) KARSTEN MANUFACTURING CORPORATION (US)
2201 West Desert Cove, Phoenix, Arizona 85029, United States of America
(72) Michael R. Nicolette (US), Bradley D. Schweigert (US), Marty R. Jertson (US), John A. Solheim (US)
(74) Công ty TNHH Sở hữu trí tuệ Vàng (GINTASSET CO., LTD.)
(55)



1.1

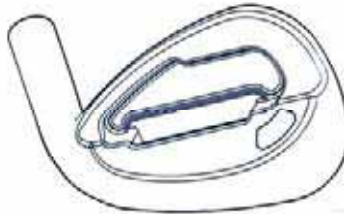

1.2

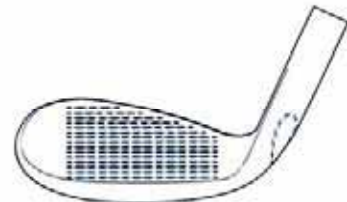

1.3



1.4



1.5



1.6

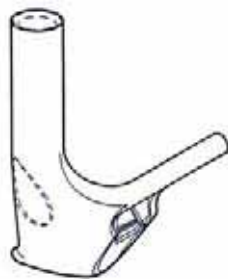

1.7

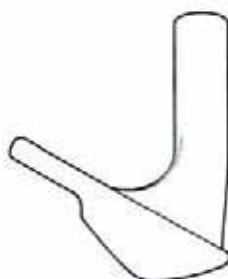

1.8



1.9

- (11) **12980**
(21) 3-2007-01807 (28) 01
(54) ĐẦU GẬY NGẮN CHƠI GÔN (51) **21-02**
(22) 18.12.2007 (43) 25.06.2008
(30) 29/282458 20.07.2007 US
(71) KARSTEN MANUFACTURING CORPORATION (US)
2201 West Desert Cove, Phoenix, Arizona 85029, United States of America
(72) David D. Jones (US), Xiaojian Chen (CN)
(74) Công ty TNHH Sở hữu trí tuệ Vàng (GINTASSET CO., LTD.)
(55)

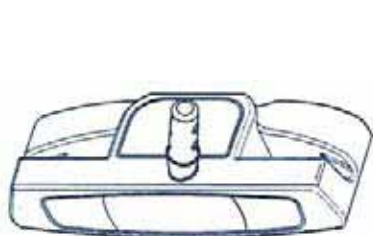

1.1

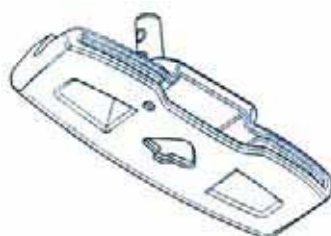

1.2



1.3



1.4



1.5



1.6



1.7

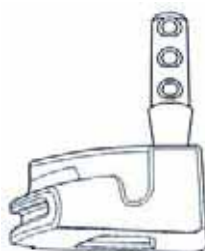

1.8



1.9

- (11) **12981**
(21) 3-2007-01808 (28) 01
(54) ĐẦU GẬY NGẮN CHƠI GÔN (51) **21-02**
(22) 18.12.2007 (43) 25.06.2008
(30) 29/282459 20.07.2007 US
(71) KARSTEN MANUFACTURING CORPORATION (US)
2201 West Desert Cove, Phoenix, Arizona 85029, United States of America
(72) David D. Jones (US), Xiaojian Chen (CN)
(74) Công ty TNHH Sở hữu trí tuệ Vàng (GINTASSET CO., LTD.)
(55)

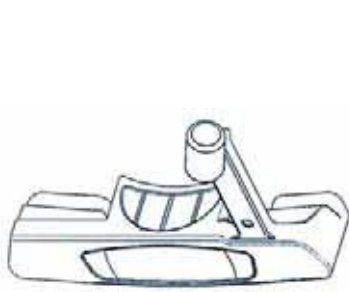

1.1

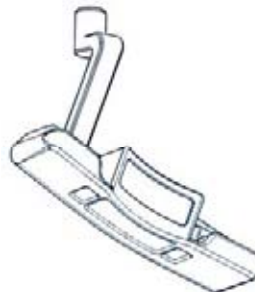

1.2



1.3



1.4

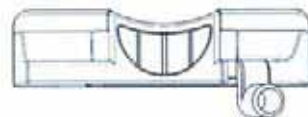

1.5



1.6



1.7

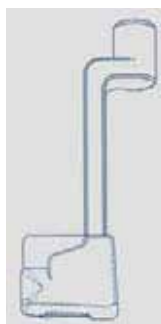

1.8



1.9

- (11) **12982**
(21) 3-2007-01809 (28) 01
(54) ĐẦU GẬY NGẮN CHƠI GÔN (51) **21-02**
(22) 18.12.2007 (43) 25.06.2008
(30) 29/282461 20.07.2007 US
(71) KARSTEN MANUFACTURING CORPORATION (US)
2201 West Desert Cove, Phoenix, Arizona 85029, United States of America
(72) David D. Jones (US), Xiaojian Chen (CN)
(74) Công ty TNHH Sở hữu trí tuệ Vàng (GINTASSET CO., LTD.)
(55)



1.1

1.2

1.3



1.4

1.5

1.6



1.7

1.8

1.9

- (11) **12983**
(21) 3-2007-01843 (28) 02
(54) BỘ HỘP ĐỰNG SẢN PHẨM GHÉP KHỚP VỚI NHAU (51) **09-03**
(22) 25.12.2007 (43) 25.06.2008
(30) 07-00876-0102 25.06.2007 MY
07-00877-0202 25.06.2007 MY
07-00878-0102 25.06.2007 MY
07-00879-0202 25.06.2007 MY
(71) COLGATE-PALMOLIVE COMPANY (US)
300 Park Avenue, New York, NY 10022, United States of America
(72) Mayuree Paklamjeak (TH), Sarawut Udomwiriyasaree (TH), Jocelyn Z. Advincula (PH),
Maria Elisa Carvajal (CO)
(74) Văn phòng luật sư Phạm và Liên danh (PHAM & ASSOCIATES)
(55)

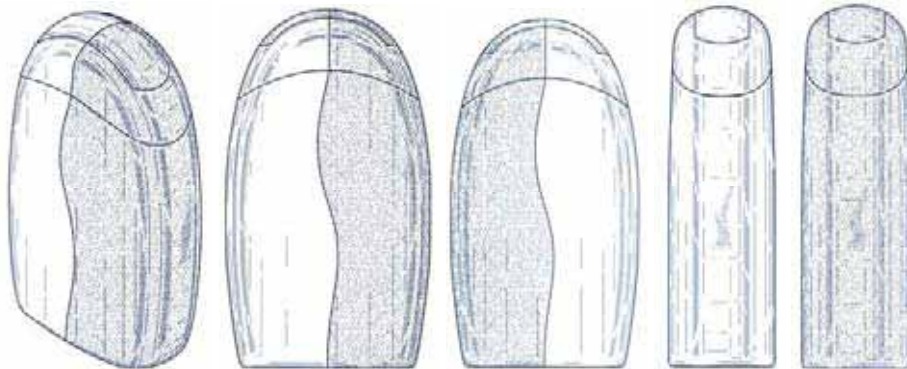

1.1

1.2

1.3

1.4

1.5

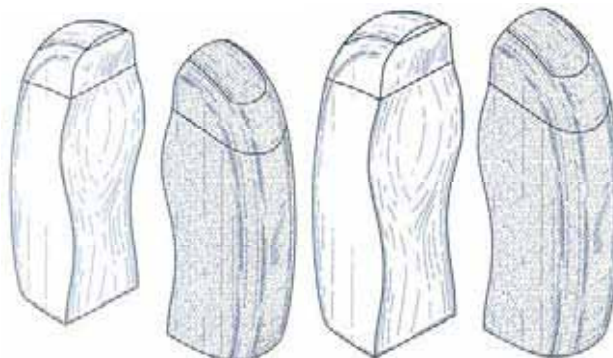

1.6

1.7

1.8

1.9

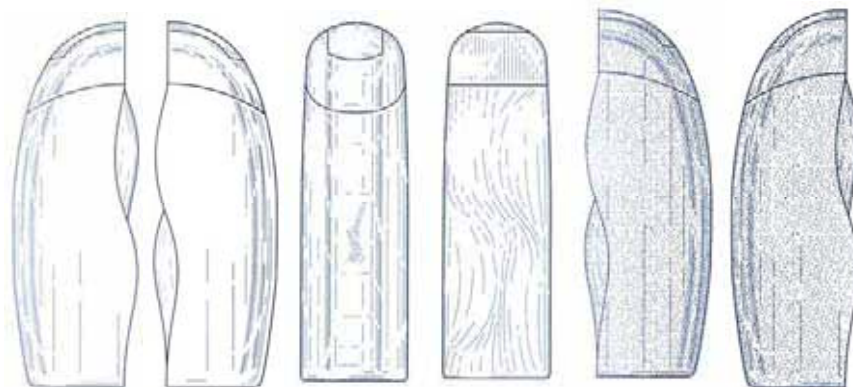

1.10 1.11 1.12 1.13 1.14 1.15



1.16 1.17 1.18 1.19 1.20 1.21

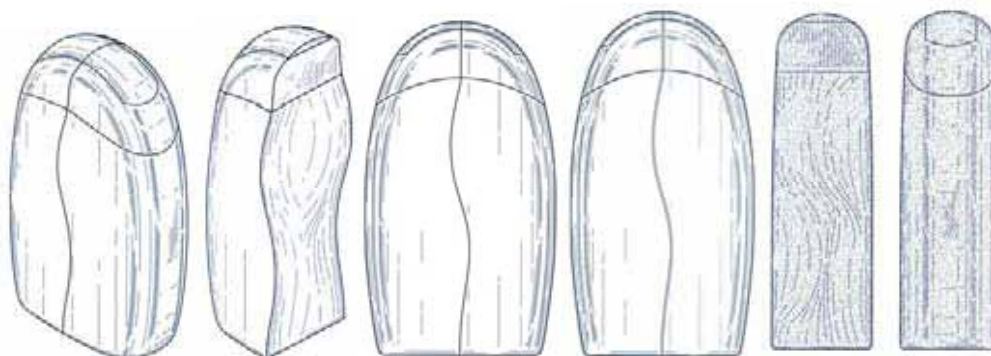

2.1 2.2 2.3 2.4 2.5 2.6

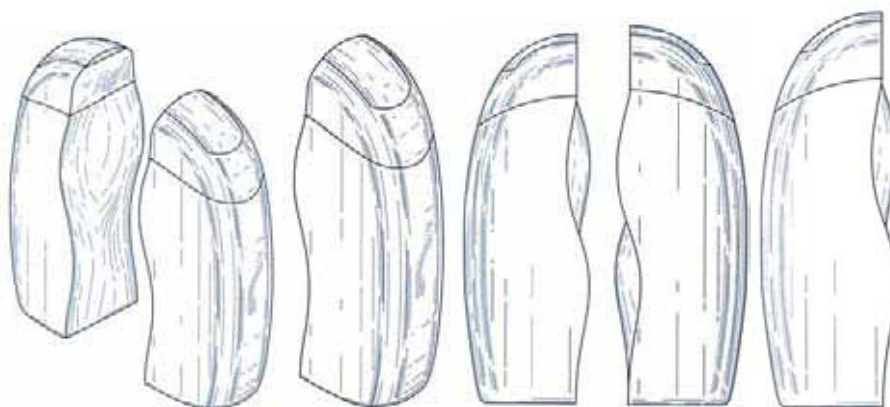

2.7 2.8 2.9 2.10 2.11 2.12

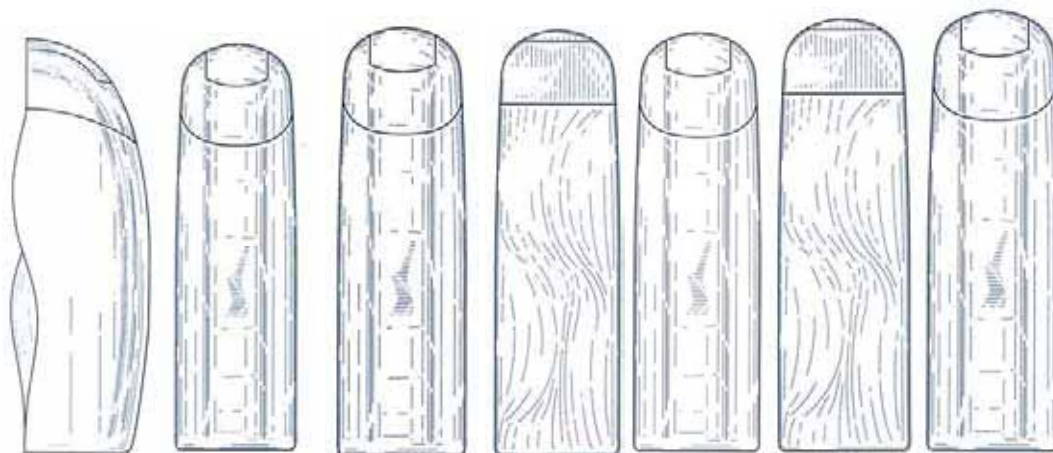

2.13

2.14

2.15

2.16

2.17

2.18

2.19



2.20

2.21

2.22

2.23

2.24

2.25

- (11) **12984**
(21) 3-2007-01852 (28) 01
(54) GIƯỜNG NGỦ (51) **06-02**
(22) 26.12.2007 (43) 25.06.2008
(71) CÔNG TY CỔ PHẦN CAO SU SÀI GÒN - KYMDAN (VN)
28 Bình Thới, phường 14, quận 11, TP. Hồ Chí Minh
(72) Nguyễn Hữu Trí (VN)
(74) Công ty TNHH Sở hữu trí tuệ Thảo Thọ Quyến (INVENCO)
(55)



1.1



1.2



1.3



1.4



1.5

- (11) **12985**
(21) 3-2007-01864 (28) 01
(54) MÓC TREO QUẦN ÁO (51) **06-08**
(22) 26.12.2007 (43) 25.06.2008
(71) TRẦN HÁN THÀNH (VN)
11A Huyện Toại, phường 12, quận 11, TP. Hồ Chí Minh
(72) Trần Hán Thành (VN)
(74) Công ty TNHH một thành viên Trường Luật (CÔNG TY TRUONG LUAT)
(55)

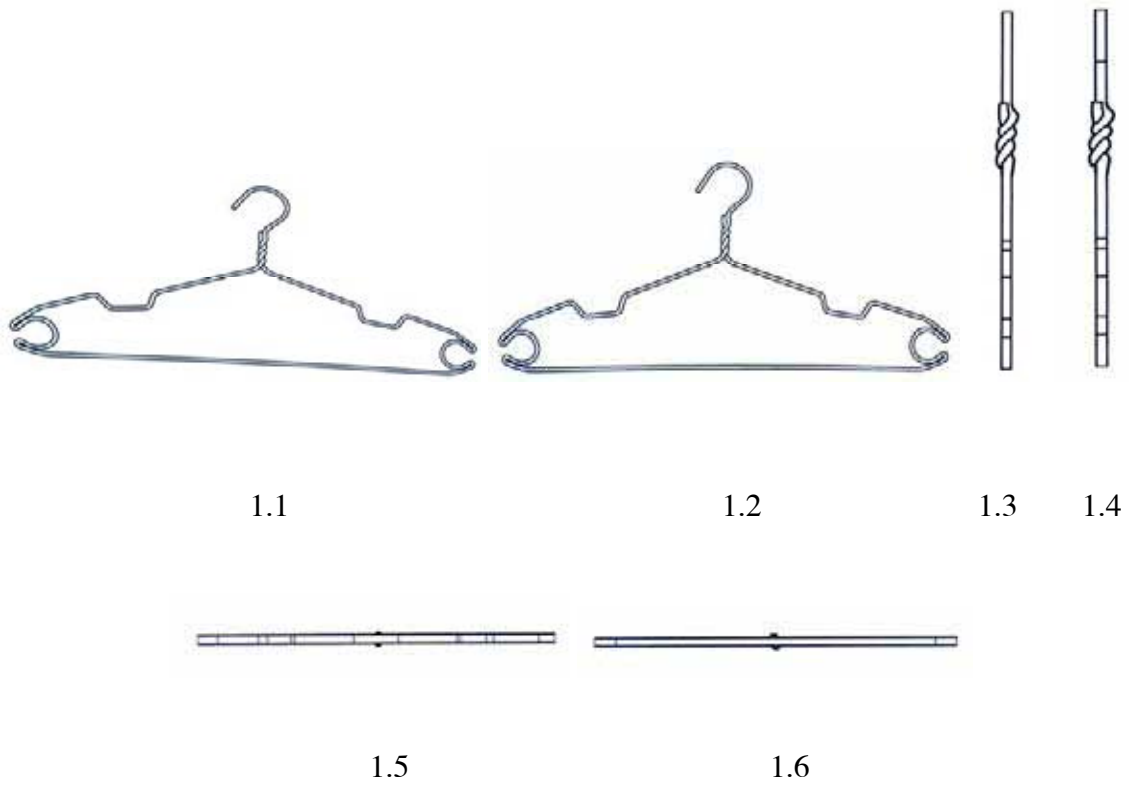

- (11) **12986**
(21) 3-2008-00015
(54) **HỘP ĐỰNG**
(22) 04.01.2008
(71) **PHẠM VĂN THANH (VN)**
Xã Hồng Thuận, huyện Giao Thủy, tỉnh Nam Định
(72) Phạm Văn Thanh (VN)
(74) Công ty TNHH Sở hữu trí tuệ Gia Việt (GIAVIET CO., LTD.)
(55)
- (28) 01
(51) **09-03**
(43) 25.06.2008



1.1



1.2

- (11) **12987**
(21) 3-2008-00046 (28) 01
(54) **NẮP CHE ĐỒNG HỒ XE MÁY** (51) **12-16**
(22) 09.01.2008 (43) 25.06.2008
(71) YAMAHA HATSUDOKI KABUSHIKI KAISHA (JP)
2500, Shingai, Iwata-shi, Shizuoka-ken, Japan
(72) Shogo Kinoshita (JP)
(74) Công ty Cổ phần Sở hữu công nghiệp INVESTIP (INVESTIP)
(55)

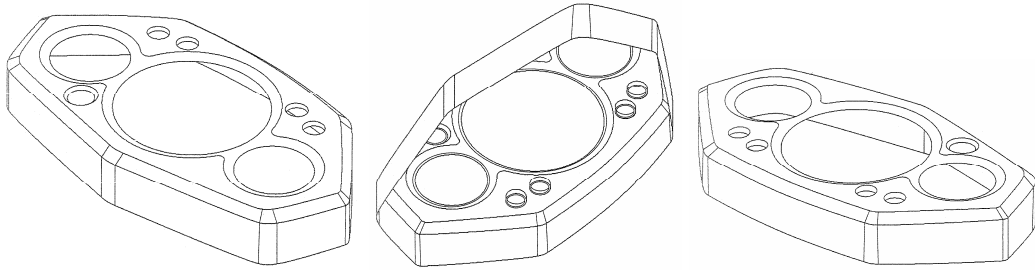

1.1

1.2

1.3

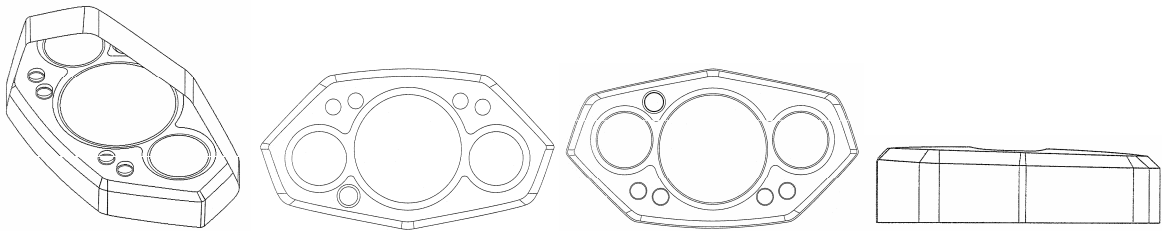

1.4

1.5

1.6

1.7



1.8

1.9

1.10



1.11

- (11) **12988**
(21) 3-2008-00077 (28) 01
(54) THIẾT BỊ NÂNG VẬN CHUYỂN (51) **12-05**
(22) 09.01.2007 (43) 25.06.2008
(71) CÔNG TY TNHH SẢN XUẤT & THƯƠNG MẠI MÁY VIỆT (VN)
Tổ 4, cụm 5, Đại Đồng, Thanh Trì, quận Hoàng Mai, thành phố Hà Nội
(72) Trịnh Thanh Tùng (VN)
(74) Công ty TNHH Ban Ca (BANCA)
(55)



1.1

1.2

1.3

1.4



1.5

1.6

1.7

1.8

- (11) **12989**
(21) 3-2008-00091 (28) 01
(54) **NẮP CHE ĐẦU PHÍA TRÊN CỦA (51) 13-99**
SỨC CÁCH ĐIỆN
(22) 14.01.2008 (43) 25.06.2008
(71) **CÔNG TY CỔ PHẦN PHÁT TRIỂN KỸ THUẬT KỸ NGUYÊN (VN)**
29 đường số 3, phường 7, quận Gò Vấp, TP. Hồ Chí Minh
(72) Nguyễn Trọng Hiếu (VN)
(74) Công ty TNHH Sở hữu trí tuệ WINCO (WINCO CO., LTD.)
(55)



1.1

1.2

1.3



1.4

1.5

1.6

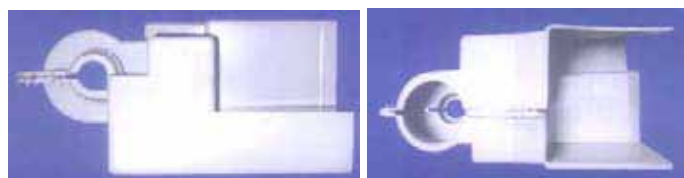

1.7

1.8

- (11) **12990**
(21) 3-2008-00107 (28) 01
(54) **BÁT TÔ** (51) **07-01**
(22) 17.01.2008 (43) 25.06.2008
(71) **CÔNG TY TRÁCH NHIỆM HỮU HẠN MINH LONG I (VN)**
333 xã Hưng Định, huyện Thuận An, tỉnh Bình Dương
(72) Lý Ngọc Minh (VN)
(74) Công ty TNHH Lê & Lê (LE & LE)
(55)



1.1



1.2



1.3



1.4

- (11) **12991**
(21) 3-2008-00108 (28) 01
(54) **BÁT TÔ** (51) **07-01**
(22) 17.01.2008 (43) 25.06.2008
(71) **CÔNG TY TRÁCH NHIỆM HỮU HẠN MINH LONG I (VN)**
333 xã Hưng Định, huyện Thuận An, tỉnh Bình Dương
(72) Lý Ngọc Minh (VN)
(74) Công ty TNHH Lê & Lê (LE & LE)
(55)



1.1

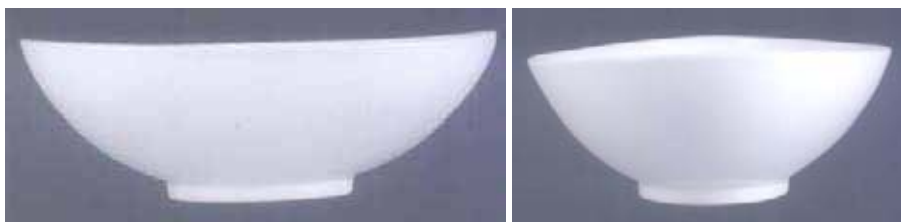

1.2

1.3

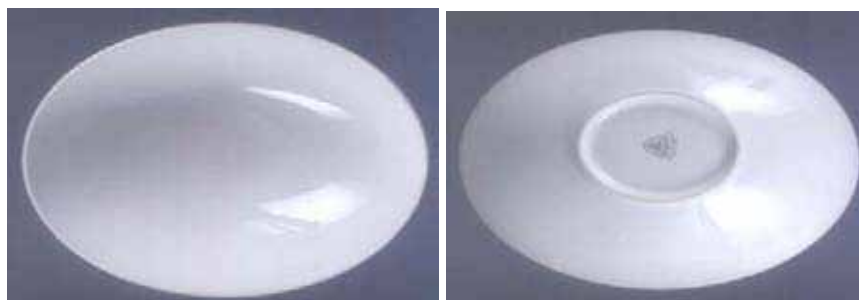

1.4

1.5

- (11) **12992**
(21) 3-2008-00109 (28) 01
(54) BÁT TÔ (51) **07-01**
(22) 17.01.2008 (43) 25.06.2008
(71) CÔNG TY TRÁCH NHIỆM HỮU HẠN MINH LONG I (VN)
333 xã Hưng Định, huyện Thuận An, tỉnh Bình Dương
(72) Lý Ngọc Minh (VN)
(74) Công ty TNHH Lê & Lê (LE & LE)
(55)



1.1



1.2



1.3



1.4

(11) **12993**

(21) 3-2008-00136

(54) HỘP MỰC IN

(22) 22.01.2008

(71) MICROJET TECHNOLOGY CO., LTD. (TW)

1F, No. 28 R&D 2nd Road, Science-Based Industrial Park, Hsinchu, Taiwan

(72) Chin-Tien Lo (TW), Chung-Chun Chiu (TW)

(74) Văn phòng luật sư Phạm và Liên danh (PHAM & ASSOCIATES)

(55)

(28) 02

(51) **18-02**

(43) 25.06.2008

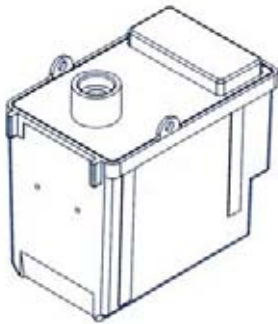

1.1

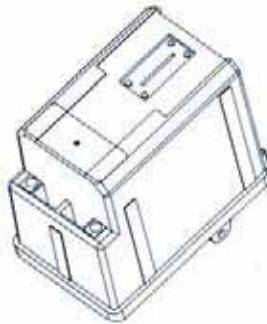

1.2

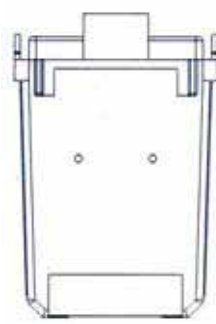

1.3

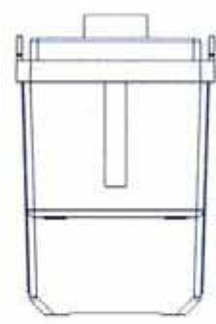

1.4

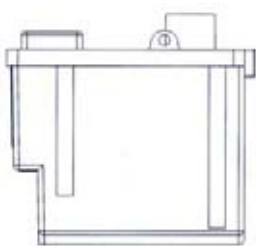

1.5

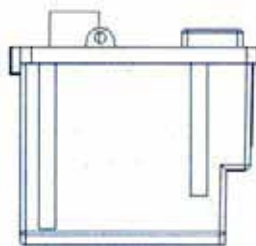

1.6

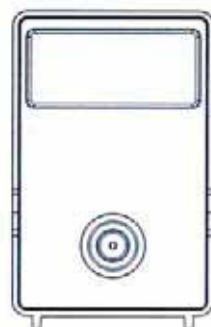

1.7

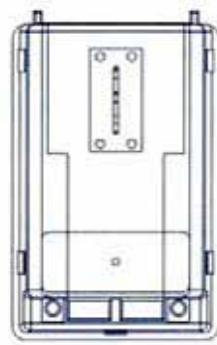

1.8

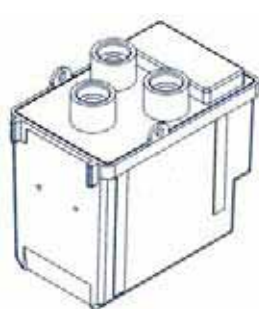

2.1

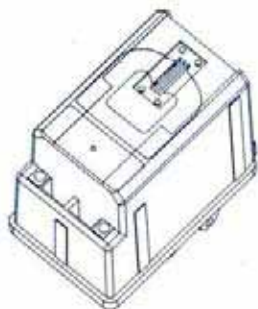

2.2

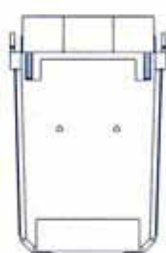

2.3

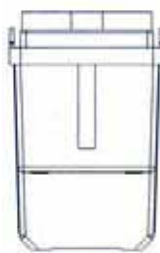

2.4

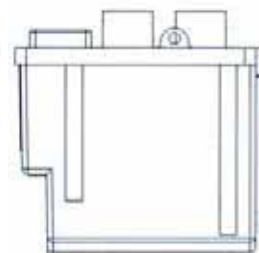

2.5

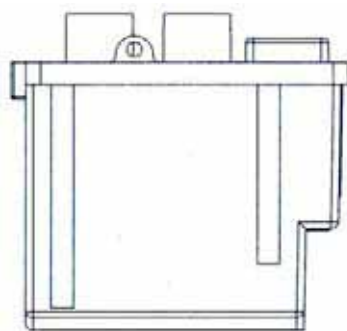

2.6

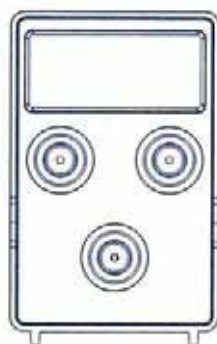

2.7

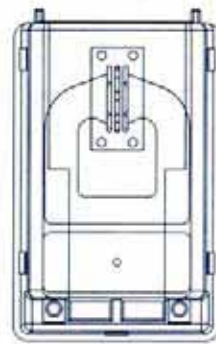

2.8

- (11) **12994**
(21) 3-2008-00137 (28) 01
(54) THẺ KHÁCH HÀNG (51) **19-08**
(22) 23.01.2008 (43) 25.06.2008
(71) NGUYỄN TỬ QUẢNG (VN)
Phường Đông Thành, thị xã Ninh Bình, tỉnh Ninh Bình
(72) Nguyễn Tử Quảng (VN)
(74) Công ty TNHH Luật Gia Phạm (PHAM JURIST CO.,LTD.)
(55)



1.1

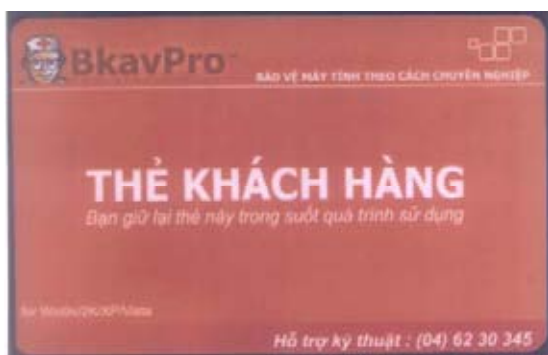

1.2



1.3

- (11) **12995**
(21) 3-2008-00156 (28) 01
(54) NAN CỬA CUỐN (51) **25-02**
(22) 25.01.2008 (43) 25.06.2008
(71) CÔNG TY TNHH SẢN XUẤT VÀ THƯƠNG MẠI HUNG PHÁT (VN)
Số 8 lô 13A, đô thị mới Trung Yên, phường Trung Hoà, quận Cầu Giấy, thành phố Hà Nội
(72) Dương Quốc Tuấn (VN)
(74) Công ty TNHH Sở hữu trí tuệ WINCO (WINCO CO., LTD.)
(55)

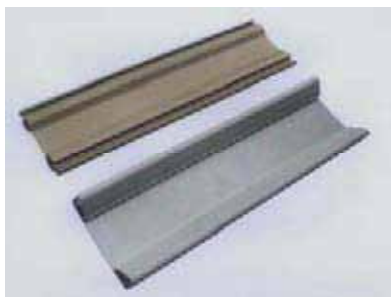

1.1

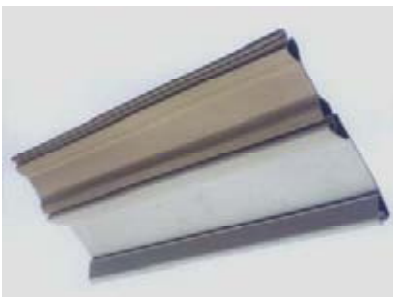

1.2



1.3



1.4

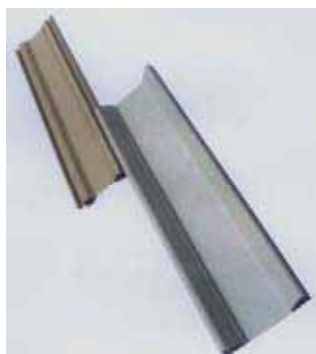

1.5



1.6



1.7



1.8

- (11) **12996**
(21) 3-2008-00157 (28) 01
(54) HỘP ĐỰNG (51) **09-03**
(22) 25.01.2008 (43) 25.06.2008
(71) PHẠM VĂN THANH (VN)
Xã Hồng Thuận, huyện Giao Thủy, tỉnh Nam Định
(72) Phạm Văn Thanh (VN)
(74) Công ty TNHH Sở hữu trí tuệ Gia Việt (GIAVIET CO., LTD.)
(55)



1.1



1.2

- (11) **12997**
(21) 3-2008-00160 (28) 01
(54) CHAI (51) **09-01**
(22) 25.01.2008 (43) 25.06.2008
(71) KIRIN BEVERAGE KABUSHIKI KAISHA (ALSO TRADING AS KIRIN BEVERAGE CORPORATION) (JP)
1, Kanda Izumi-Cho, Chiyoda-Ku, Tokyo, Japan
(72) Yukinobu SAITO (JP)
(74) Văn phòng luật sư Phạm và Liên danh (PHAM & ASSOCIATES)
(55)



1.1

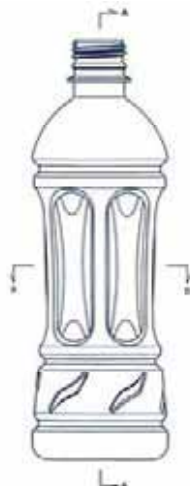

1.2



1.3



1.4



1.5



1.6

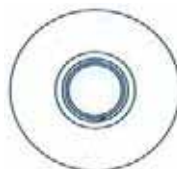

1.7

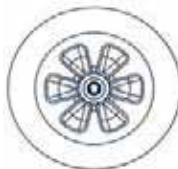

1.8

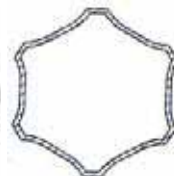

1.9

- (11) **12998**
(21) 3-2008-00179 (28) 02
(54) **ĐẦU GẬY NGẮN CHƠI GÔN** (51) **21-02**
(22) 30.01.2008 (43) 25.06.2008
(30) 29/283495 15.08.2007 US
(30) 29/283497 15.08.2007 US
(71) **KARSTEN MANUFACTURING CORPORATION (US)**
2201 West Desert Cove, Phoenix, Arizona 85029, United States of America
(72) Michael R. Nicolette (US), Bradley D. Schweigert (US), David D. Jones (US), Marty R. Jertson (US)
(74) Công ty TNHH Sở hữu trí tuệ Vàng (GINTASSET CO., LTD.)
(55)

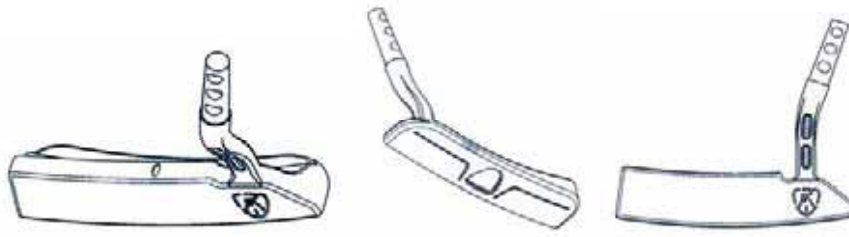

1.1

1.2

1.3

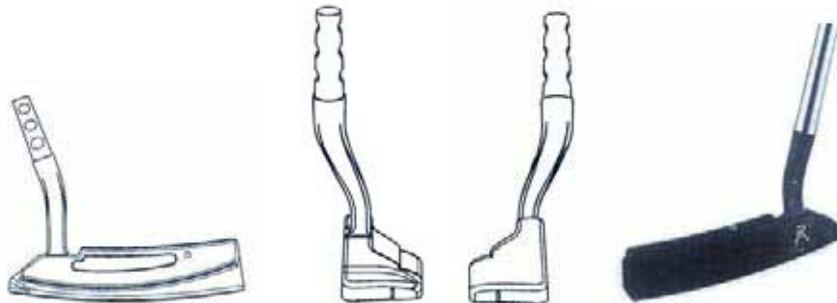

1.4

1.5

1.6

1.7



1.8

1.9

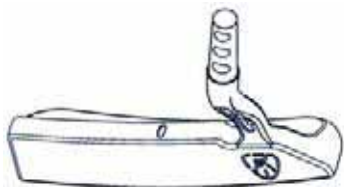

2.1



2.2



2.3



2.4



2.5



2.6



2.7



2.8



2.9

- (11) **12999**
 (21) 3-2008-00180 (28) 02
 (54) ĐẦU GẬY NGẮN CHƠI GÔN (51) **21-02**
 (22) 30.01.2008 (43) 25.06.2008
 (30) 29/283496 15.08.2007 US
 29/283494 15.08.2007 US
 (71) KARSTEN MANUFACTURING CORPORATION (US)
 2201 West Desert Cove, Phoenix, Arizona 85029, United States of America
 (72) Michael R. Nicolette (US), Bradley D. Schweigert (US), David D. Jones (US), Marty R. Jertson (US)
 (74) Công ty TNHH Sở hữu trí tuệ Vàng (GINTASSET CO., LTD.)
 (55)

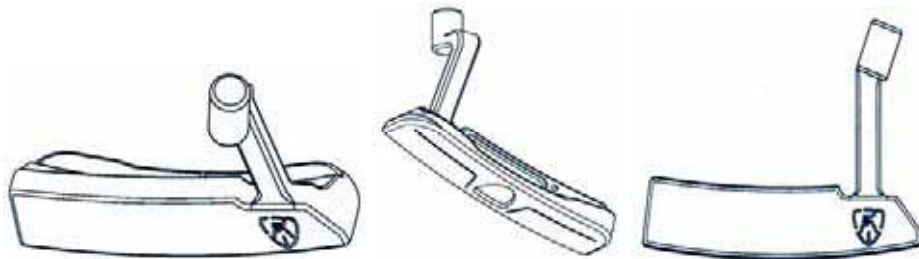

1.1

1.2

1.3

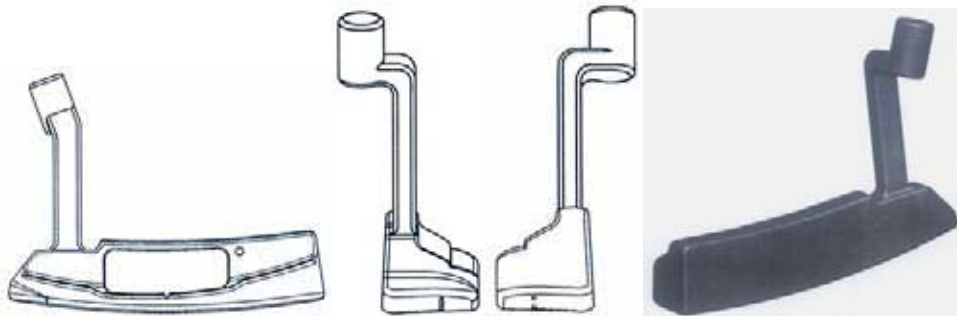

1.4

1.5

1.6

1.7



1.8

1.9

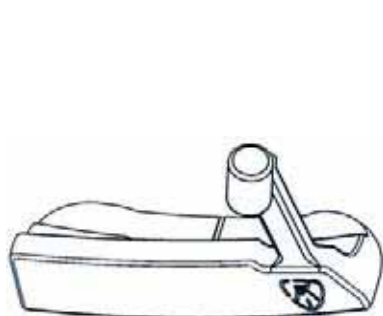

2.1

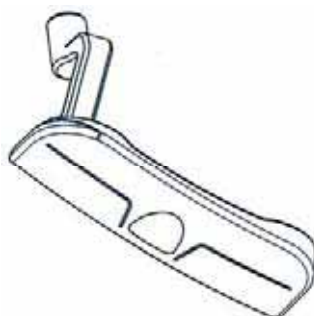

2.2

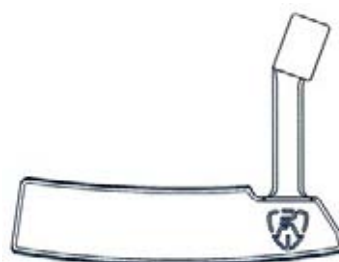

2.3

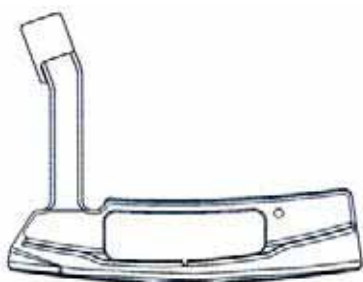

2.4

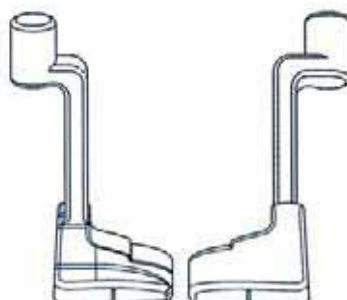

2.5

2.6



2.7

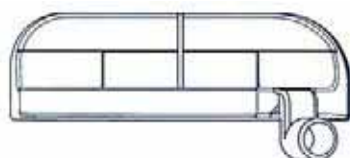

2.8

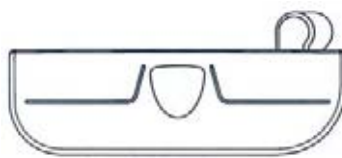

2.9

- (11) **13000**
(21) 3-2008-00181 (28) 01
(54) ĐẦU GẬY NGẮN CHƠI GÔN (51) **21-02**
(22) 30.01.2008 (43) 25.06.2008
(30) 29/283348 10.08.2007 US
(71) KARSTEN MANUFACTURING CORPORATION (US)
2201 West Desert Cove, Phoenix, Arizona 85029, United States of America
(72) David D. Jones (US)
(74) Công ty TNHH Sở hữu trí tuệ Vàng (GINTASSET CO., LTD.)
(55)



1.1

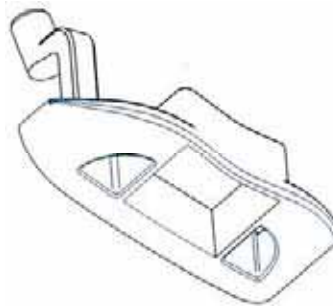

1.2

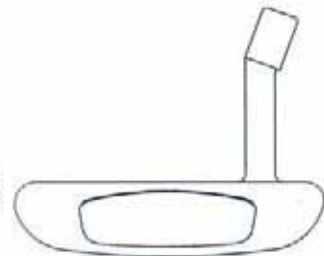

1.3



1.4

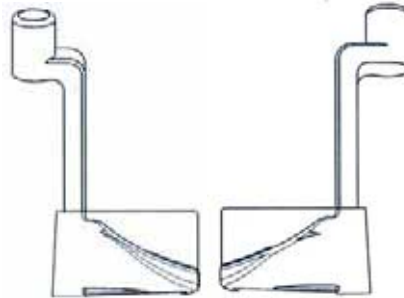

1.5

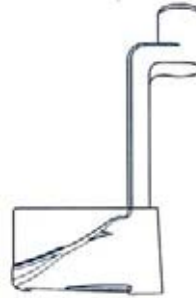

1.6



1.7

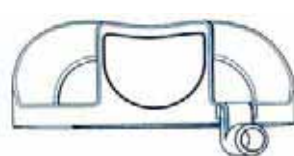

1.8

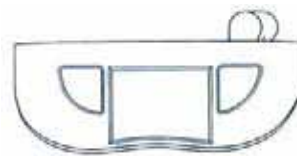

1.9

- (11) **13001**
(21) 3-2008-00187 (28) 01
(54) CÔNG TẮC ĐIỆN (51) **13-03**
(22) 30.01.2008 (43) 25.06.2008
(30) 316506 30.07.2007 AU
(71) CLIPSAL AUSTRALIA PTY LTD. (AU)
12 Park Terrace Bowden 5007, South Australia, Australia
(72) Eddy Rinna (AU), Alvin Lam (AU)
(74) Công ty TNHH một thành viên Sở hữu trí tuệ VCCI (VCCI-IP CO.,LTD)
(55)

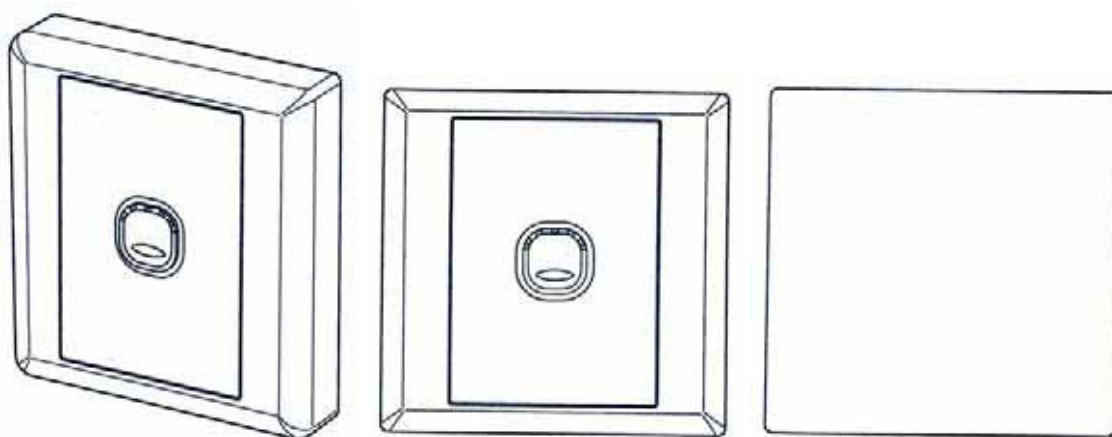

1.1

1.2

1.3

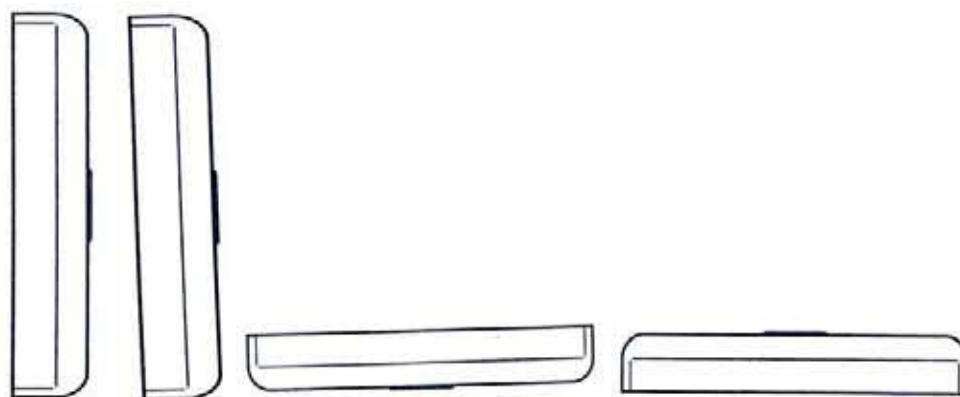

1.4

1.5

1.6

1.7

- (11) **13002**
(21) 3-2008-00188 (28) 01
(54) CÔNG TẮC ĐIỆN (51) **13-03**
(22) 30.01.2008 (43) 25.06.2008
(30) 316508 30.07.2007 AU
(71) CLIPSAL AUSTRALIA PTY LTD. (AU)
12 Park Terrace Bowden 5007, South Australia, Australia
(72) Eddy Rinna (AU), Alvin Lam (AU)
(74) Công ty TNHH một thành viên Sở hữu trí tuệ VCCI (VCCI-IP CO.,LTD)
(55)

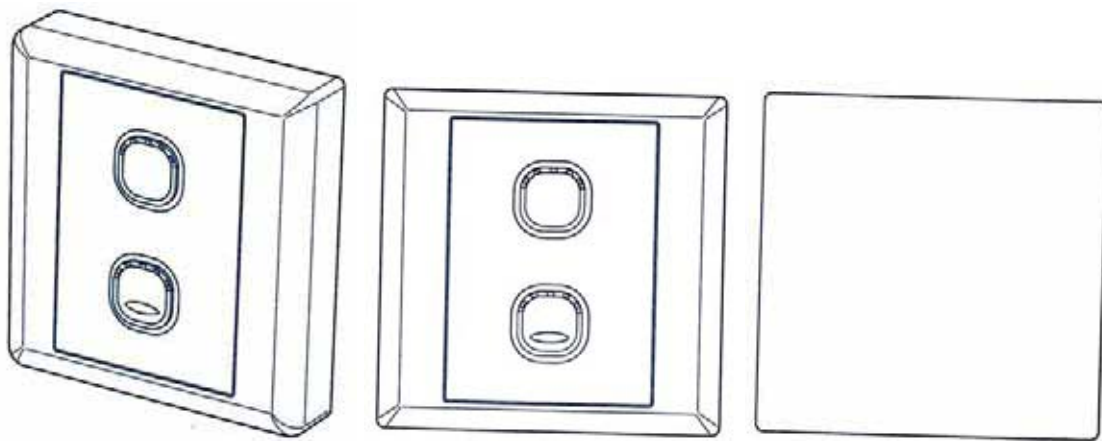

1.1

1.2

1.3

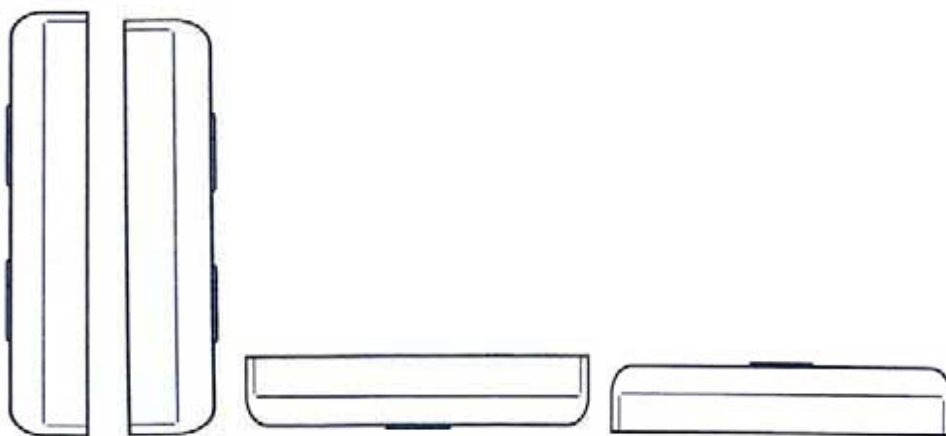

1.4

1.5

1.6

1.7

- (11) **13003**
(21) 3-2008-00197 (28) 01
(54) MẶT NẠ XE MÁY (51) **12-16**
(22) 01.02.2008 (43) 25.06.2008
(71) CÔNG TY CỔ PHẦN CÔNG NGHIỆP TÀU THỦY VÀ XE MÁY VINASHLN (VN)
109 Quán Thánh, quận Ba Đình, thành phố Hà Nội
(72) Vũ Mạnh Hà (VN)
(55)



1.1



1.2



1.3



1.4



1.5

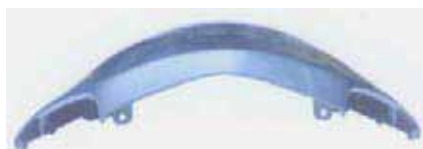

1.6

- (11) **13004**
(21) 3-2008-00205 (28) 01
(54) BÌNH ĐỰNG HOÁ CHẤT (51) **09-01**
(22) 01.02.2008 (43) 25.06.2008
(71) CÔNG TY TNHH HOÁ CHẤT MINH PHÁT (VN)
251 Trịnh Đình Trọng, phường Hoà Thạnh, quận Tân Phú, TP. Hồ Chí Minh
(72) Nguyễn Thụy Phương (VN)
(74) Công ty TNHH Sở hữu trí tuệ Ngôi Sao chuyên nghiệp và liên danh (NOVAPRO & ASSOCIATES CO.,LTD.)
(55)



1.1

1.2

1.3

1.4



1.5



1.6



1.7

- (11) **13005**
(21) 3-2008-00215 (28) 01
(54) TÚI ĐỰNG BỘT ĐẬU ĐEN (51) **09-05**
(22) 04.02.2008 (43) 25.06.2008
(71) CÔNG TY CỔ PHẦN THƯƠNG MẠI RỒNG VÀNG MINH NGỌC (VN)
Khu 6, phường Cẩm Thượng, thành phố Hải Dương, tỉnh Hải Dương
(72) Thái Thị Vân Anh (VN)
(55)



1.1



1.2

- (11) **13006**
(21) 3-2008-00232 (28) 01
(54) XE MÁY (51) **12-11**
(22) 12.02.2008 (43) 25.06.2008
(30) 2007-021597 08.08.2007 JP
(71) HONDA MOTOR CO., LTD. (JP)
1-1, Minami-Aoyama 2-chome, Minato-ku, Tokyo, Japan
(72) Witoon Rerksiriwan (TH), Yutapong Damroong (TH)
(74) Văn phòng luật sư Phạm và Liên danh (PHAM & ASSOCIATES)
(55)



1.1

1.2

1.3



1.4

1.5

1.6



1.7

1.8

1.9

1.10

- (11) **13007**
(21) 3-2008-00236 (28) 01
(54) GHẾ (51) **06-01**
(22) 13.02.2008 (43) 25.06.2008
(71) CÔNG TY CỔ PHẦN CAO SU SÀI GÒN - KYMDAN (VN)
28 Bình Thới, phường 14, quận 11, TP. Hồ Chí Minh
(72) Nguyễn Hữu Trí (VN)
(74) Công ty TNHH Sở hữu trí tuệ Thảo Thọ Quyến (INVENCO)
(55)

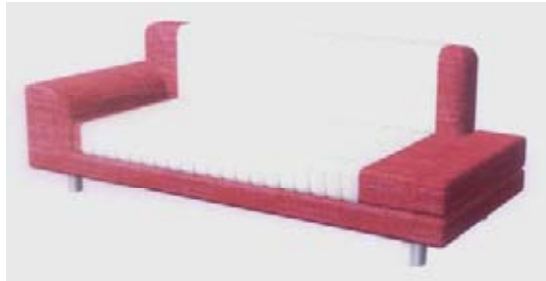

1.1



1.2



1.3

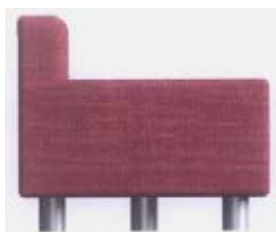

1.4



1.5



1.6

- (11) **13008**
(21) 3-2008-00241 (28) 01
(54) TÚI ĐỰNG LY (51) **09-05**
(22) 14.02.2008 (43) 25.06.2008
(71) CÔNG TY CỔ PHẦN DIỆU THƯỜNG (VN)
ấp Long Đức 1, xã Tam Phước, huyện Long Thành, tỉnh Đồng Nai
(72) Lương Huệ Phương (VN)
(74) Công ty Cổ phần Sở hữu công nghiệp INVESTIP (INVESTIP)
(55)

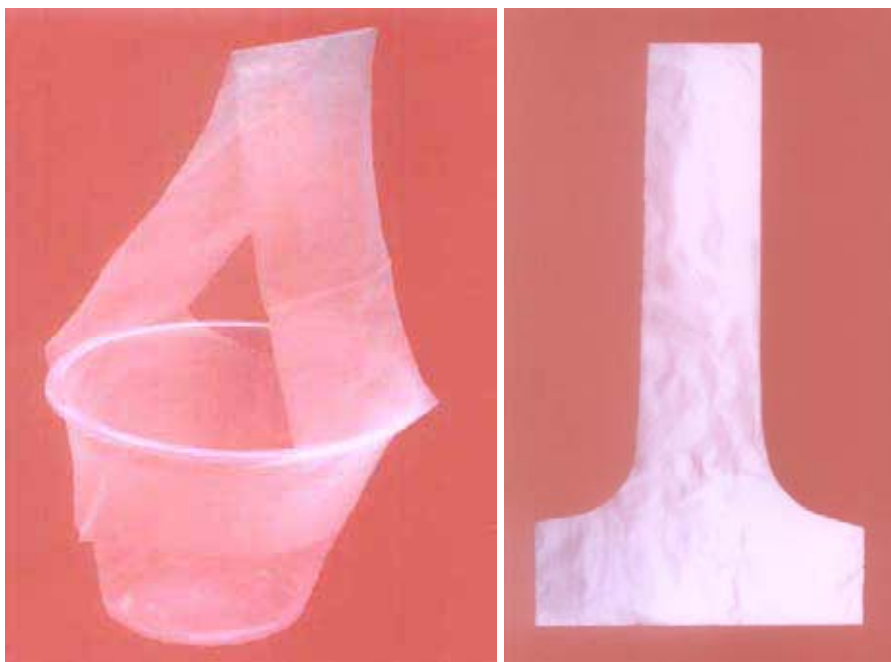

1.1

1.2

- (11) **13009**
(21) 3-2008-00242 (28) 01
(54) ĐÈN (51) **26-03**
(22) 14.02.2008 (43) 25.06.2008
(30) 000775911 21.08.2007 EM
(71) KONINKLIJKE PHILIPS ELECTRONICS N.V. (NL)
Groenewoudseweg 1, 5621 BA Eindhoven, The Netherlands
(72) Allan Quanguo Wang (CN)
(74) Công ty Cổ phần Sở hữu công nghiệp INVESTIP (INVESTIP)
(55)

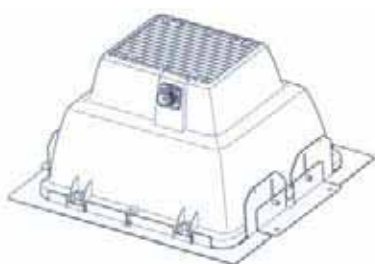

1.1

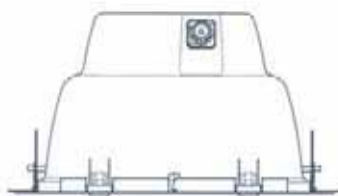

1.2

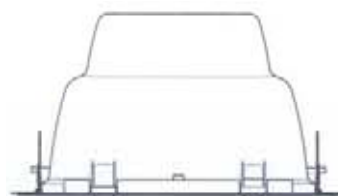

1.3



1.4

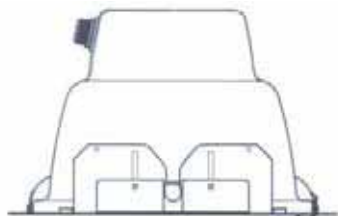

1.5

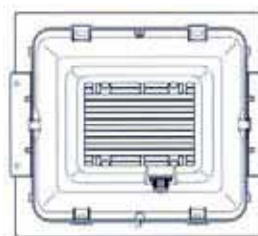

1.6

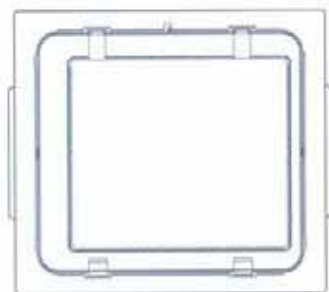

1.7

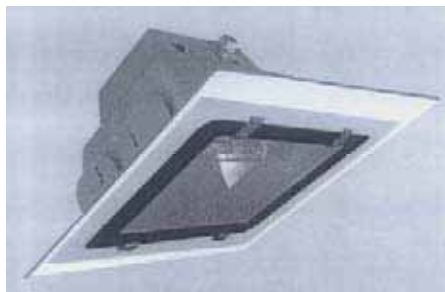

1.8

- (11) **13010**
(21) 3-2008-00253 (28) 01
(54) NHÃN SẢN PHẨM (51) **19-08**
(22) 18.02.2008 (43) 25.06.2008
(71) CÔNG TY TNHH SÀI GÒN NHÀ (VN)
132-134 Điện Biên Phủ, phường ĐaKao, quận 1, TP. Hồ Chí Minh
(72) Nguyễn Thị Thu Trâm (VN)
(74) Công ty TNHH Luật Gia Phạm (PHAM JURIST CO.,LTD.)
(55)

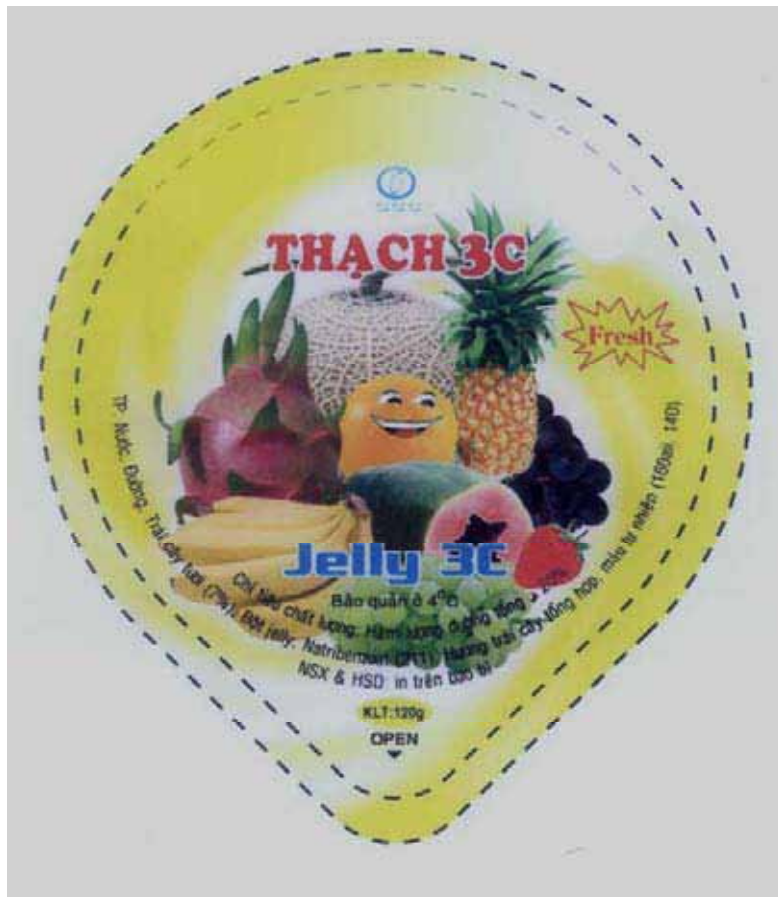

- (11) **13011**
(21) 3-2008-00254 (28) 01
(54) NHÃN SẢN PHẨM (51) **19-08**
(22) 18.02.2008 (43) 25.06.2008
(71) CÔNG TY TNHH SÀI GÒN NHÀ (VN)
132-134 Điện Biên Phủ, phường ĐaKao, quận 1, TP. Hồ Chí Minh.
(72) Nguyễn Thị Thu Trâm (VN)
(74) Công ty TNHH Luật Gia Phạm (PHAM JURIST CO.,LTD.)
(55)

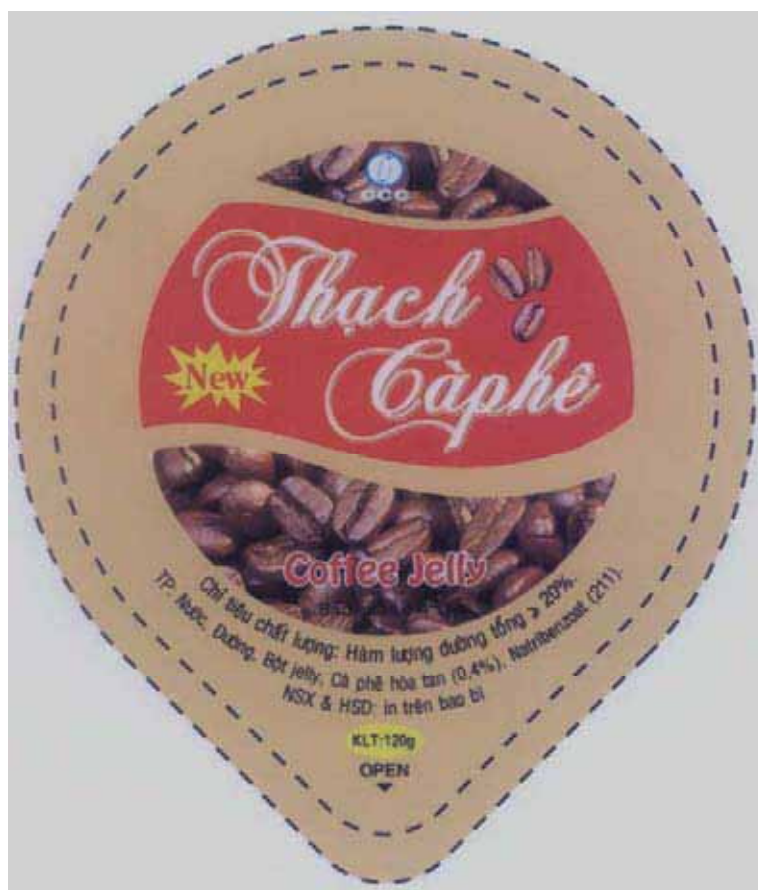

- (11) **13012**
(21) 3-2008-00255 (28) 01
(54) BAO GÓI ĐẬU PHỘNG (51) **09-05**
(22) 18.02.2008 (43) 25.06.2008
(71) CÔNG TY TNHH CÔNG NGHIỆP THỰC PHẨM TẤT THẮNG (VN)
614B, thôn 14, xã Tam Thắng, huyện Cư Jút, tỉnh Đắk Nông
(72) Nguyễn Tất Thắng (VN)
(74) Công ty TNHH Ban Ca (BANCA)
(55)



1.1



1.2

- (11) **13013**
(21) 3-2008-00256 (28) 01
(54) CHAI (51) **09-01**
(22) 18.02.2008 (43) 25.06.2008
(30) 4003996 17.08.2007 GB
(71) UNILEVER N.V. (NL)
Weena 455, 3013 AL Rotterdam, Netherlands
(72) Rolf HERING (DE)
(74) Công ty TNHH Trần Hữu Nam và Đồng sự (TRAN H.N & ASS.)
(55)

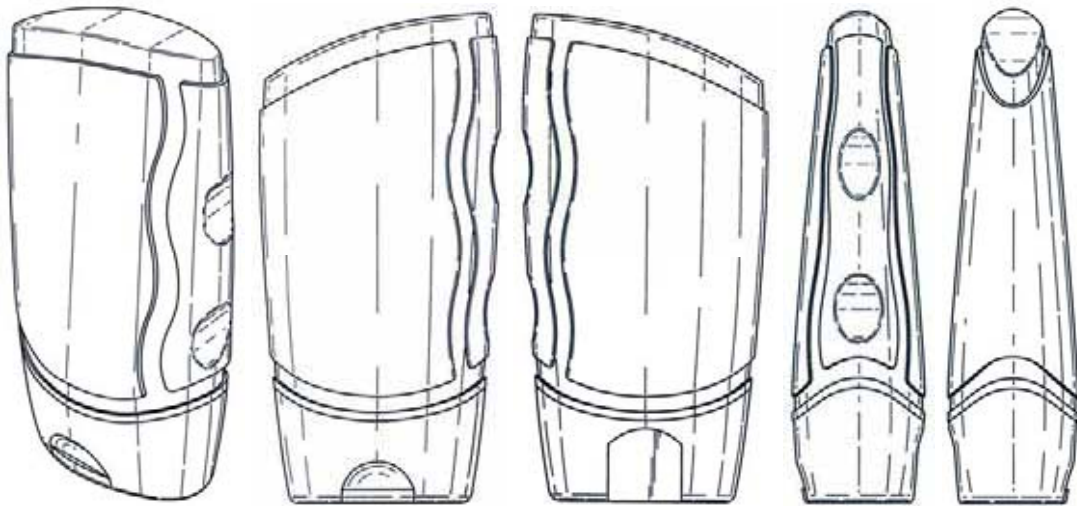

1.1

1.2

1.3

1.4

1.5

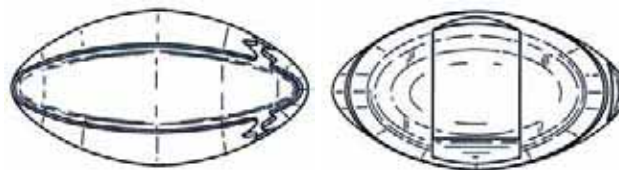

1.6

1.7

- (11) **13014**
(21) 3-2008-00260 (28) 01
(54) GHẾ (51) **06-01**
(22) 19.02.2008 (43) 25.06.2008
(71) CÔNG TY CỔ PHẦN CAO SU SÀI GÒN - KYMDAN (VN)
28 Bình Thới, phường 14, quận 11, TP. Hồ Chí Minh
(72) Nguyễn Hữu Trí (VN)
(74) Công ty TNHH Sở hữu trí tuệ Thảo Thọ Quyến (INVENCO)
(55)



1.1



1.2



1.3



1.4



1.5

- (11) **13015**
(21) 3-2008-00280 (28) 01
(54) MÁY XÚC ĐÁ PHÒNG NỔ (51) **15-04**
(22) 22.02.2008 (43) 25.06.2008
(71) CÔNG TY CỔ PHẦN CƠ ĐIỆN UÔNG BÍ (VN)
Phường Bắc Sơn, thị xã Uông Bí, tỉnh Quảng Ninh
(72) Nguyễn Trọng Quảng (VN), Nguyễn Minh Tâm (VN), Nguyễn Văn Tới (VN)
(74) Công ty TNHH Nghiên cứu và Tư vấn chuyển giao công nghệ và đầu tư (CONCETTI)
(55)



1.1

1.2

1.3



1.4

1.5

1.6



1.7

1.8

1.9

1.10

1.11

1.12

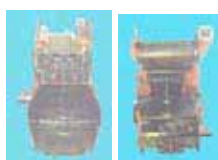

1.13

1.14

- (11) **13016**
(21) 3-2008-00281 (28) 01
(54) TỦ LẠNH (51) **15-07**
(22) 22.02.2008 (43) 25.06.2008
(30) 2007-026042 26.09.2007 JP
(71) HAIER SANYO ELECTRIC CO., LTD. (JP)
5-4, Takanawa, 1-chome, Minato-ku, Tokyo, Japan
(72) Hidehiko SATOU (JP), Naoyuki FUKUDA (JP), Nobuhiko HOSHINO (JP)
(74) Công ty TNHH Quốc tế D & N (D&N INTERNATIONAL CO.,LTD.)
(55)

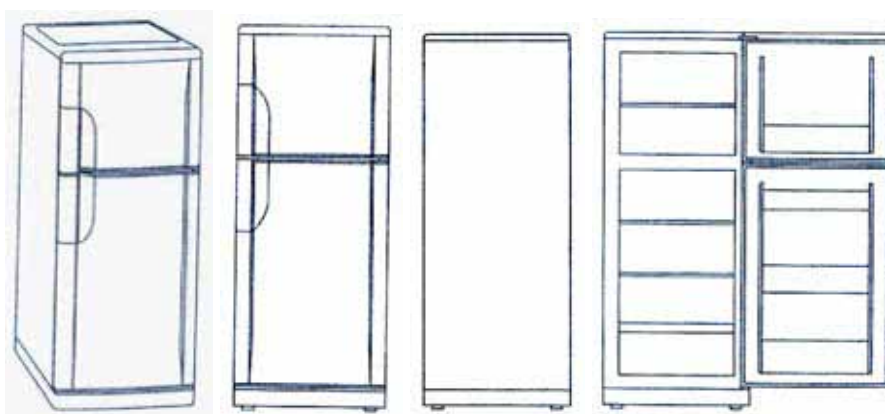

1.1

1.2

1.3

1.4

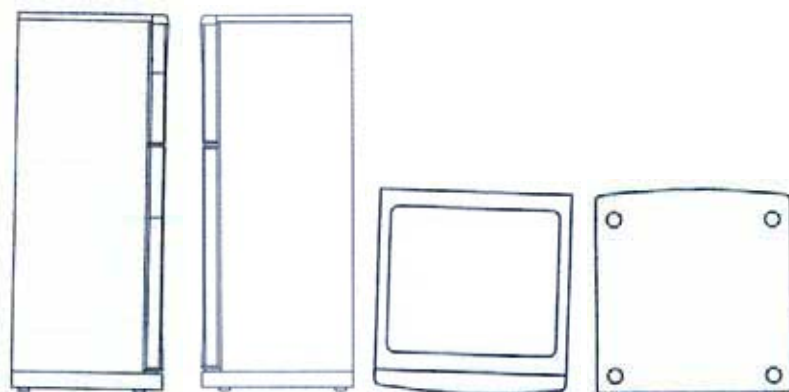

1.5

1.6

1.7

1.8

- (11) **13017**
(21) 3-2008-00282 (28) 01
(54) TỦ LẠNH (51) **15-07**
(22) 22.02.2008 (43) 25.06.2008
(30) 2007-026043 26.09.2007 JP
(71) HAIER SANYO ELECTRIC CO., LTD. (JP)
5-4, Takanawa, 1-chome, Minato-ku, Tokyo, Japan
(72) Naoyuki FUKUDA (JP), Hidehiko SATOU (JP), Susumu YAMAGUCHI (JP),
Nobuhiko HOSHINO (JP)
(74) Công ty TNHH Quốc tế D & N (D&N INTERNATIONAL CO.,LTD.)
(55)

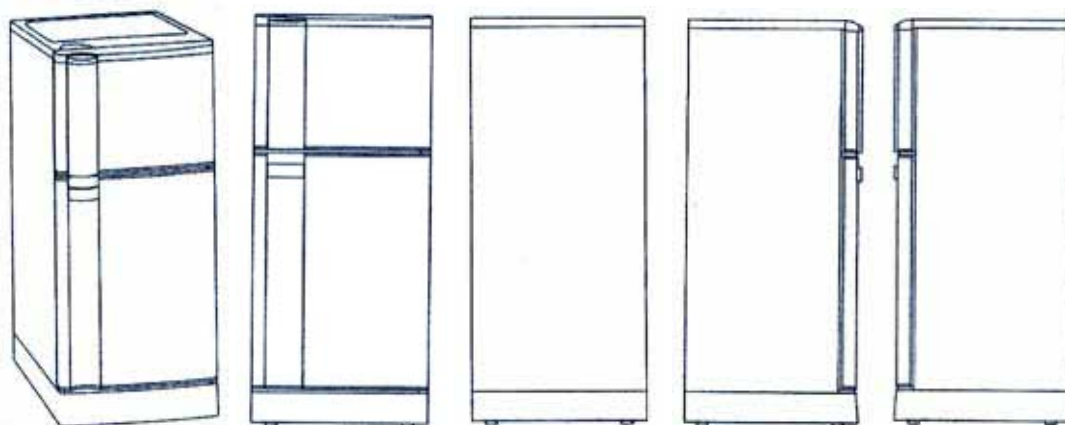

1.1

1.2

1.3

1.4

1.5

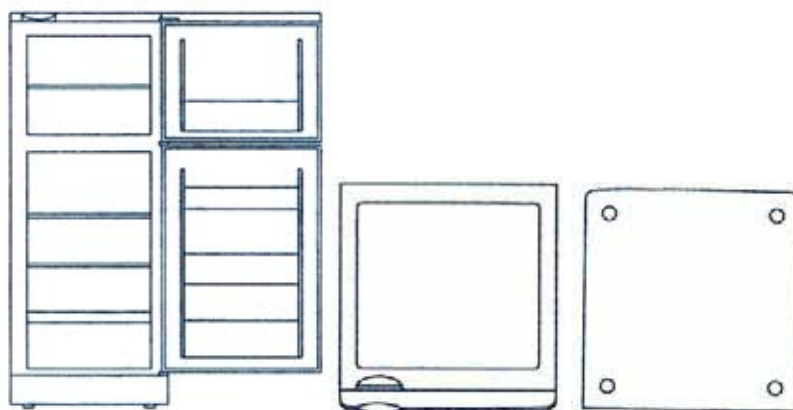

1.6

1.7

1.8

- (11) **13018**
(21) 3-2008-00291 (28) 01
(54) DÉP (51) **02-04**
(22) 26.02.2008 (43) 25.06.2008
(71) DOANH NGHIỆP TƯ NHÂN GIÀY Á CHÂU (VN)
567/K 35 J Nguyễn Tri Phương, phường 14, quận 10, TP. Hồ Chí Minh
(72) Nguyễn Đình Kim (VN)
(74) Công ty TNHH A.M.B.Y.S (AMBYS CO.LTD.)
(55)



1.1



1.2



1.3



1.4



1.5



1.6

- (11) **13019**
(21) 3-2008-00297
(54) LỌ NHỎ THUỐC
(22) 28.02.2008
(71) OTSUKA PHARMACEUTICAL CO., LTD. (JP)
2-9, Kanda-Tsukasamachi, Chiyoda-ku, Tokyo 101-8535, Japan
(72) Takashi Fujimoto (JP), Shun-ichiro Sumida (JP)
(74) Văn phòng luật sư Phạm và Liên danh (PHAM & ASSOCIATES)
(55)
- (28) 01
(51) **09-01**
(43) 25.06.2008

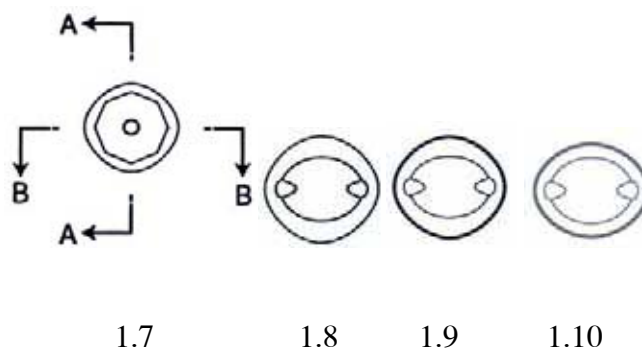
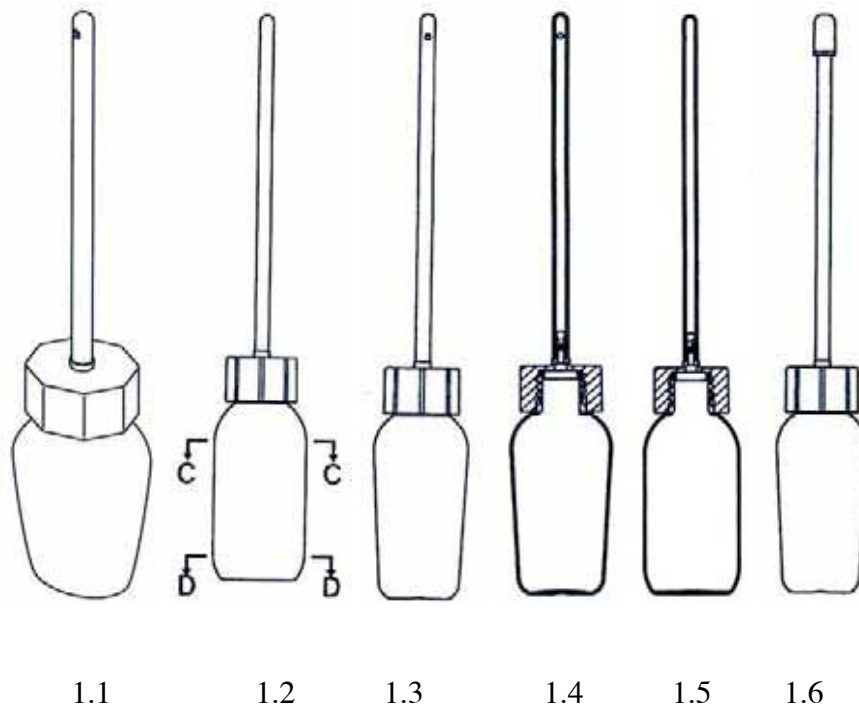

- (11) **13020**
(21) 3-2008-00306 (28) 01
(54) KHÓA ĐIỀU CHỈNH DÂY (51) **02-07**
(22) 29.02.2008 (43) 25.06.2008
(30) 96304953 06.09.2007 TW
(71) NIFCO TAIWAN CORPORATION (TW)
7th Floor, China General Plastic Bldg. No. 3, Tun-Hwa S. Road., Sec. 1, Taipei
(72) HSIAO, HSIUNG-MING (TW)
(74) Công ty TNHH Sở hữu trí tuệ Thảo Thọ Quyển (INVENCO)
(55)

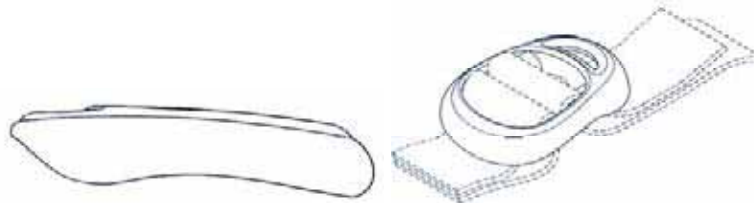
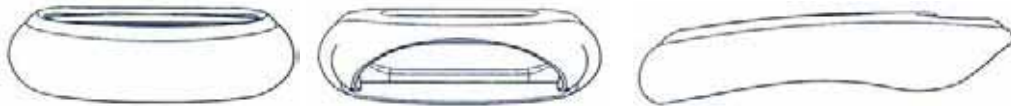
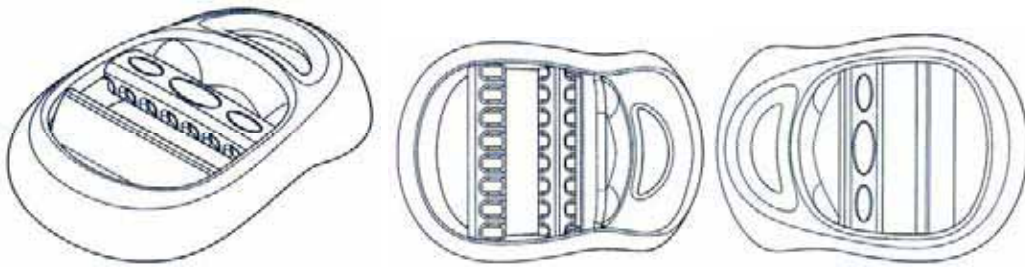

- (11) **13021**
(21) 3-2008-00309 (28) 02
(54) **ÁO QUAN** (51) **99-00**
(22) 29.02.2008 (43) 25.06.2008
(71) CÔNG TY TNHH Ý THIÊN (VN)
ấp An Hòa, xã Hoà Lợi, huyện Bến Cát, tỉnh Bình Dương
(72) Tạ Thị Kim Phượng (VN)
(74) Văn phòng Luật sư A.M.B.Y.S. Sài Gòn (AMBYS SAIGON LAW OFFICE)
(55)



1.1

1.2

1.3



1.4

1.5

1.6



1.1



1.2



1.3

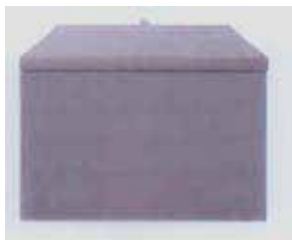

1.4



1.5



1.6

- (11) **13022**
(21) 3-2008-00313 (28) 01
(54) MÁY ĐỌC THẺ THU PHÍ TỰ ĐỘNG (51) **14-99**
(22) 03.03.2008 (43) 25.06.2008
(30) 2007-025011 14.09.2007 JP
(71) MITSUBISHI HEAVY INDUSTRIES, LTD. (JP)
16-5, Konan 2-chome, Minato-ku, Tokyo 108-8215, Japan
(72) Takashi MAEDA (JP), Takakazu TSUJI (JP), Hisaji TAKEUCHI (JP)
(74) Công ty TNHH Sở hữu trí tuệ Thảo Thọ Quyển (INVENCO)
(55)



1.1



1.2

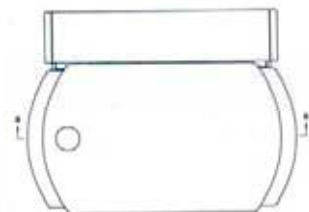

1.3

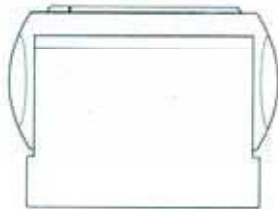

1.4



1.5



1.6



1.7



1.8



1.9



1.10

- (11) **13023**
(21) 3-2008-00315
(54) CHAI
(22) 04.03.2008
(30) 0702002335 07.09.2007 TH
(71) TROPICANA PRODUCTS INC. (US)
1001 13th Avenue East, Bradenton, Florida, 34208, United States of America
(72) Yen Heng Boon (SG)
(74) Văn phòng Luật sư Minh & Chiến (MINH, CHIEN & PARTNERS)
(55)
- (28) 01
(51) **09-01**
(43) 25.06.2008



1.1



1.2



1.3



1.4

- (11) **13024**
(21) 3-2008-00317 (28) 01
(54) BĂNG VỆ SINH (51) **24-04**
(22) 04.03.2008 (43) 25.06.2008
(30) 000790415-0001 04.09.2007 EM
(71) SCA HYGIENE PRODUCTS AB (SE)
SE-405 03, Goteborg, Sweden
(72) Cilla Persson (SE), Magdalena Gunnarsson (SE), Angelica Burvall (SE)
(74) Công ty TNHH Sở hữu trí tuệ Vàng (GINTASSET CO., LTD.)
(55)

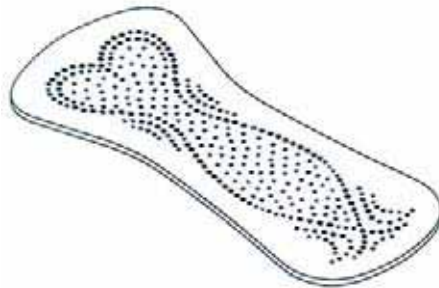

1.1

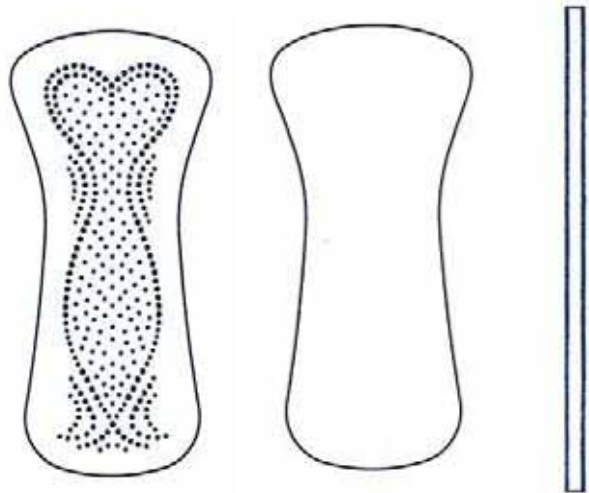

1.2

1.3

1.4



1.5

- (11) **13025**
(21) 3-2008-00318
(54) BĂNG VỆ SINH
(22) 04.03.2008
(30) 000790415-0002 04.09.2007 EM
(71) SCA HYGIENE PRODUCTS AB (SE)
SE-405 03, Goteborg, Sweden
(72) Cilla Persson (SE), Magdalena Gunnarsson (SE), Angelica Burvall (SE)
(74) Công ty TNHH Sở hữu trí tuệ Vàng (GINTASSET CO., LTD.)
(55)
- (28) 01
(51) **24-04**
(43) 25.06.2008

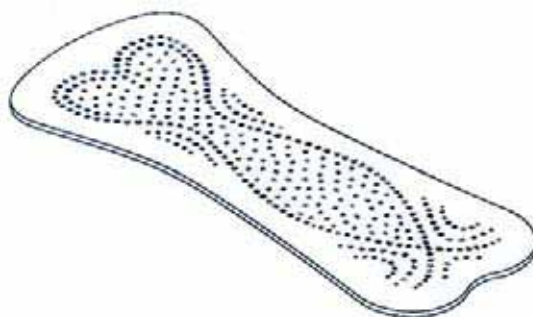

1.1

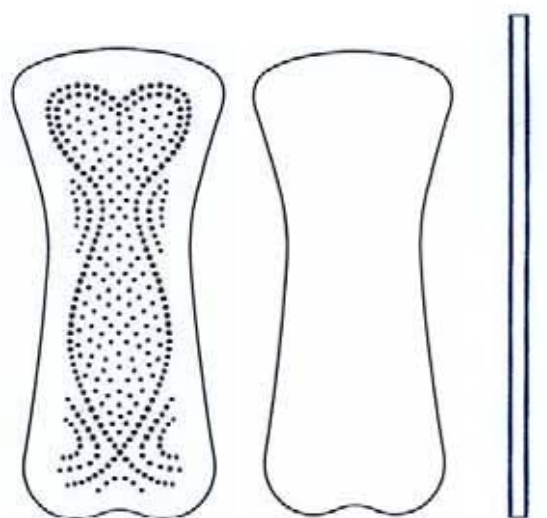

1.2

1.3

1.4

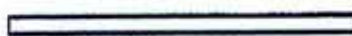

1.5

- (11) **13026**
(21) 3-2008-00319 (28) 01
(54) BĂNG VỆ SINH (51) **24-04**
(22) 04.03.2008 (43) 25.06.2008
(30) 000790415-0008 04.09.2007 EM
(71) SCA HYGIENE PRODUCTS AB (SE)
SE-405 03, Goteborg, Sweden
(72) Magdalena Gunnarsson (SE)
(74) Công ty TNHH Sở hữu trí tuệ Vàng (GINTASSET CO., LTD.)
(55)

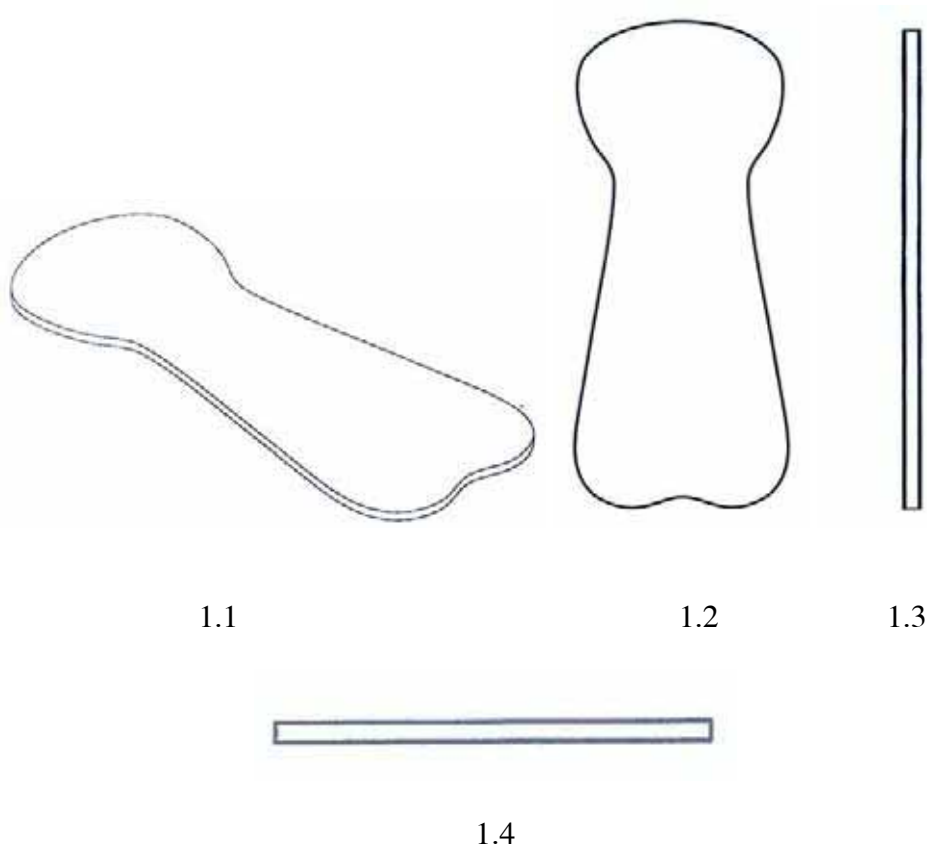

- (11) **13027**
(21) 3-2008-00320 (28) 01
(54) BĂNG VỆ SINH (51) **24-04**
(22) 04.03.2008 (43) 25.06.2008
(30) 000790415-0004 04.09.2007 EM
(71) SCA HYGIENE PRODUCTS AB (SE)
SE-405 03, Goteborg, Sweden
(72) Magdalena Gunnarsson (SE)
(74) Công ty TNHH Sở hữu trí tuệ Vàng (GINTASSET CO., LTD.)
(55)

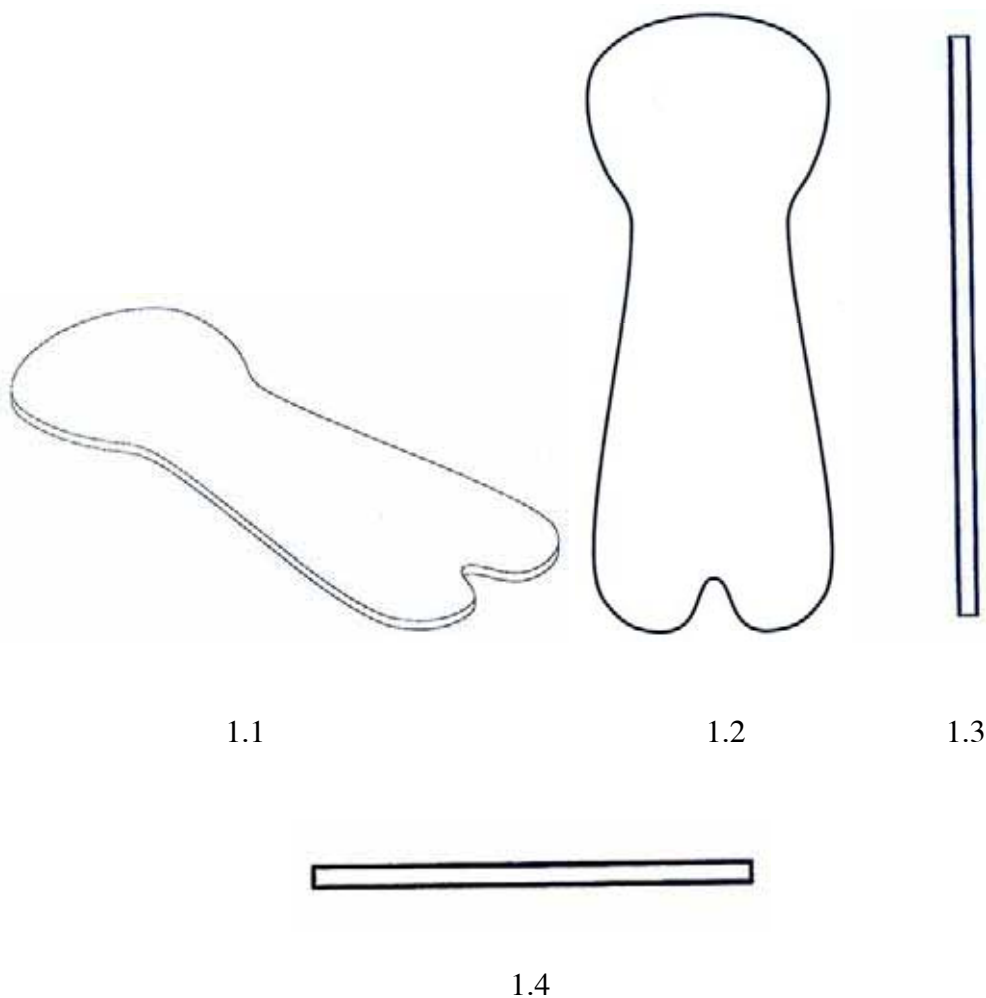

- (11) **13028**
(21) 3-2008-00321 (28) 01
(54) BÚT BI (51) **19-06**
(22) 05.03.2008 (43) 25.06.2008
(71) PLATINUM PEN CO., LTD. (JP)
3-3, Higashi Ueno 3-chome, Taito-ku, Tokyo, Japan
(72) Takashi Yanagisako (JP)
(74) Công ty TNHH một thành viên Sở hữu trí tuệ VCCI (VCCI-IP CO.,LTD)
(55)

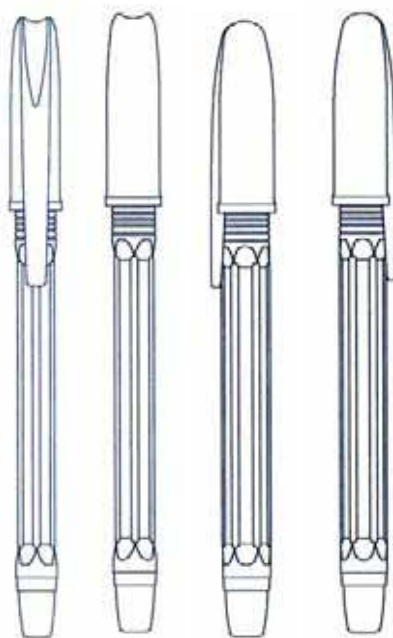

1.1 1.2 1.3 1.4

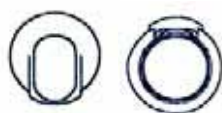

1.5 1.6

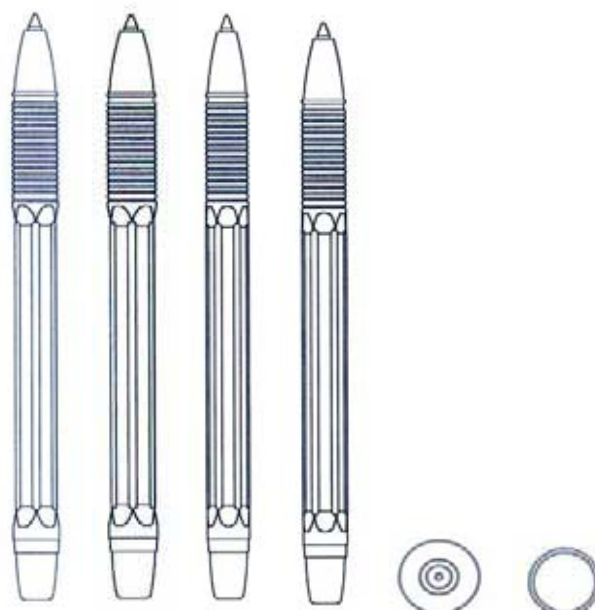

1.7 1.8 1.9 1.10 1.11 1.12

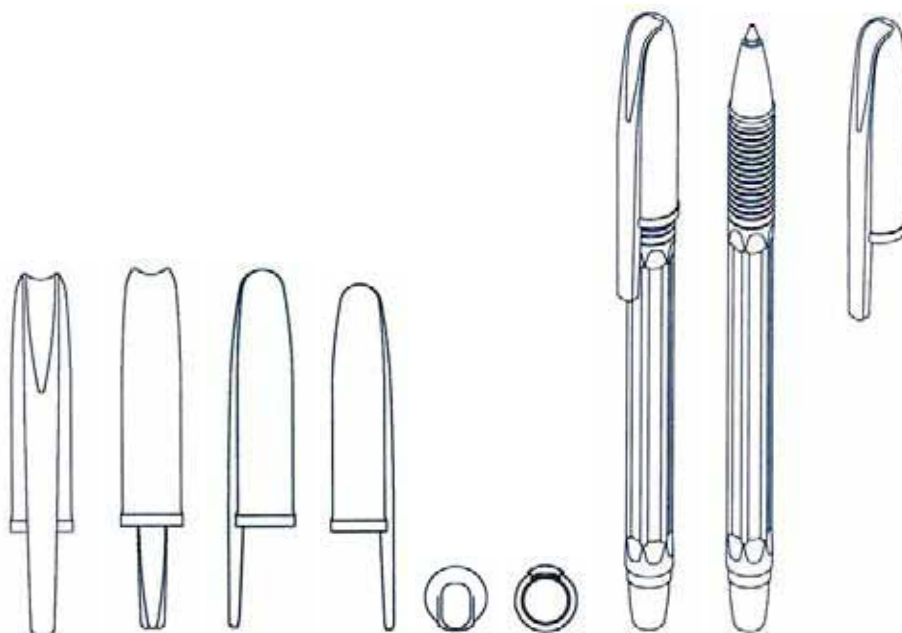

1.13 1.14 1.15 1.16 1.17 1.18 1.19 1.20

- (11) **13029**
(21) 3-2008-00330 (28) 01
(54) MÁY GIAO DỊCH TỰ ĐỘNG (51) **20-01**
(22) 06.03.2008 (43) 25.06.2008
(71) CÔNG TY CỔ PHẦN CHỨNG KHOÁN DOANH NGHIỆP NHỎ VÀ VỪA VIỆT NAM (VN)
Tầng 3-4, toà nhà Vinaplast-TaiTam, 39A Ngô Quyền, quận Hoàn Kiếm, thành phố Hà Nội
(72) Nguyễn Thanh Nam (VN)
(74) Công ty TNHH Trường Xuân (AGELESS CO.,LTD.)
(55)



1.1



1.2



1.3



1.4



1.5

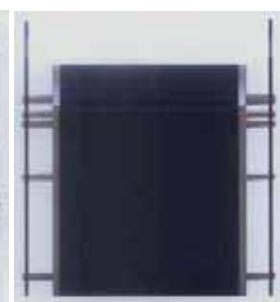

1.6

- (11) **13030**
 (21) 3-2008-00340 (28) 01
 (54) **ỐNG XÔNG THUỐC** (51) **24-02**
 (22) 07.03.2008 (43) 25.06.2008
 (30) 000788682 12.09.2007 EM
 (71) SIEGFRIED GENERICS INTERNATIONAL AG (CH)
 Untere Bruehlstrasse 4, CH-4800 Zofingen, Switzerland
 (72) Stefan MAYER (DE)
 (74) Công ty TNHH Tầm nhìn và Liên danh (VISION & ASSOCIATES CO.LTD.)
 (55)

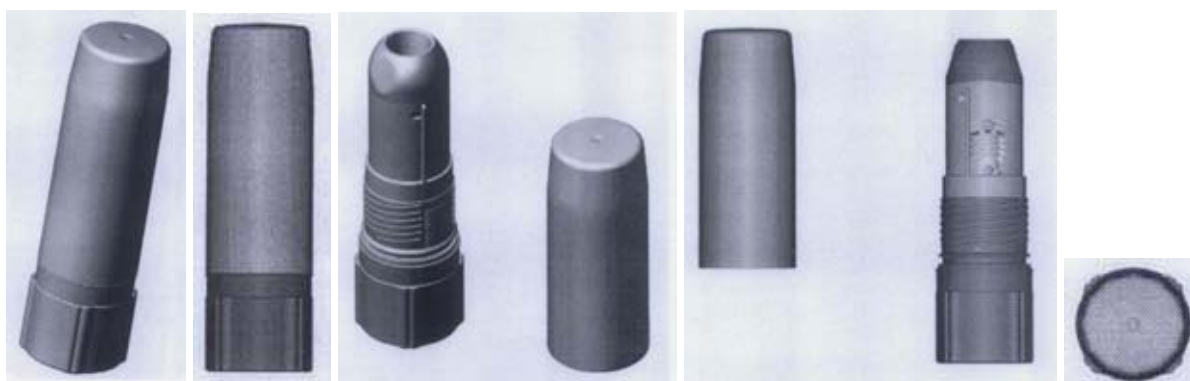

1.1

1.2

1.3

1.4

1.5

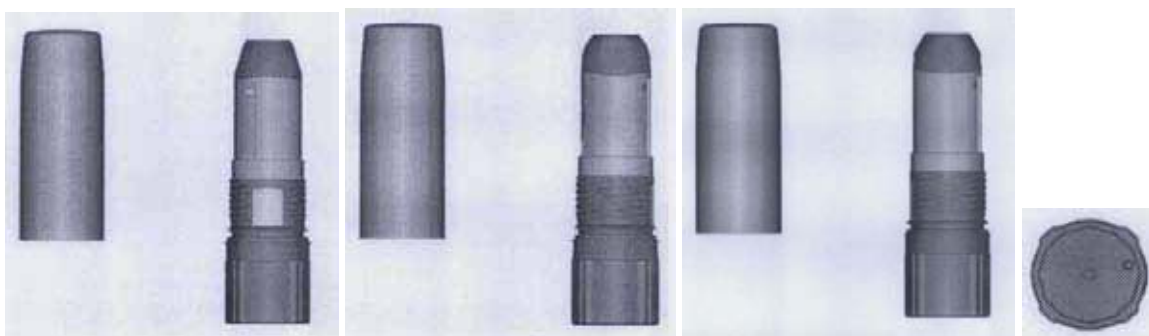

1.5

1.6

1.7

1.8

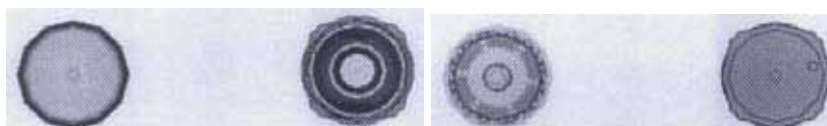

1.9

1.10

- (11) **13031**
(21) 3-2008-00341 (28) 01
(54) XE Ô TÔ (51) **12-08**
(22) 10.03.2008 (43) 25.06.2008
(71) CÔNG TY TNHH CHẾ TẠO CƠ GIỚI NÔNG NGHIỆP MIỀN BẮC (VN)
Khu công nghiệp Phố Nối A, quốc lộ 5, xã Giai Phạm, huyện Yên Mỹ, tỉnh Hưng Yên
(72) Phan Văn Thiện (VN)
(74) Công ty TNHH Trường Xuân (AGELESS CO.,LTD.)
(55)



1.1



1.2



1.3



1.4



1.5



1.6

- (11) **13032**
(21) 3-2008-00346 (28) 01
(54) LÒ NƯỚNG (51) **07-02**
(22) 11.03.2008 (43) 25.06.2008
(71) CÔNG TY TNHH SẢN XUẤT THƯƠNG MẠI KIẾN AN (VN)
269/20/7 Vĩnh Viễn, phường 5, quận 10, TP. Hồ Chí Minh
(72) Lai Cường (VN)
(74) Công ty TNHH Sở hữu trí tuệ WINCO (WINCO CO., LTD.)
(55)



1.1

1.2

1.3

1.4



1.5

1.6

1.7

- (11) **13033**
(21) 3-2008-00350 (28) 01
(54) HỘP MỤC (51) **18-02**
(22) 12.03.2008 (43) 25.06.2008
(30) 2007-025013 14.09.2007 JP
(71) TOSHIBA TEC KABUSHIKI KAISHA (JP)
2-17-2, Higashigotanda, Shinagawa-ku, Tokyo, Japan
(72) Yoshiaki TANAKA (JP)
(74) Công ty TNHH một thành viên Sở hữu trí tuệ VCCI (VCCI-IP CO.,LTD)
(55)



1.1

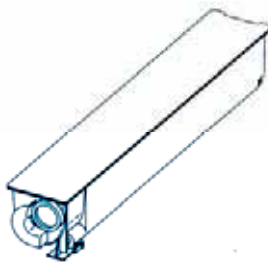

1.2



1.3



1.4



1.5



1.6



1.7



1.8



1.9



1.10



1.11



1.12

- (11) **13034**
(21) 3-2008-00351 (28) 01
(54) HỘP MỤC (51) **18-02**
(22) 12.03.2008 (43) 25.06.2008
(30) 2007-025012 14.09.2007 JP
(71) TOSHIBA TEC KABUSHIKI KAISHA (JP)
2-17-2, Higashigotanda, Shinagawa-ku, Tokyo, Japan
(72) Yoshiaki TANAKA (JP)
(74) Công ty TNHH một thành viên Sở hữu trí tuệ VCCI (VCCI-IP CO.,LTD)
(55)

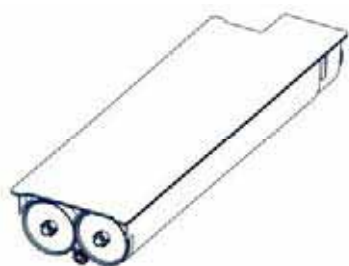

1.1



1.2



1.3



1.4



1.5



1.6



1.7

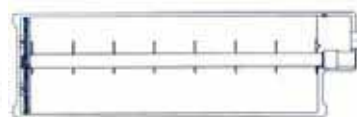

1.8



1.9



1.10



1.11



1.12

CÔNG BÁO SỞ HỮU CÔNG NGHIỆP SỐ 243 TẬP A (06.2008)

- (11) **13035**
(21) 3-2008-00417 (28) 02
(54) BAO GÓI SNACK CUA (51) **09-05**
(22) 26.03.2008 (43) 25.06.2008
(71) CÔNG TY CỔ PHẦN TRÀNG AN (TRANG AN JOINT-STOCK COMPANY) (VN)
Phố Phùng Chí Kiên, phường Nghĩa Đô, quận Cầu Giấy, thành phố Hà Nội
(72) Trịnh Sỹ (VN)
(74) Công ty TNHH Sở hữu trí tuệ Thảo Thọ Quyến (INVENCO)
(55)



1.1



1.2



2.1



2.2

- (11) **13036**
 (21) 3-2008-00418 (28) 02
 (54) BAO GÓI SNACK BÒ (51) **09-05**
 (22) 26.03.2008 (43) 25.06.2008
 (71) CÔNG TY CỔ PHẦN TRĂNG AN (TRANG AN JOINT-STOCK COMPANY) (VN)
 Phố Phùng Chí Kiên, phường Nghĩa Đô, quận Cầu Giấy, thành phố Hà Nội
 (72) Trịnh Sỹ (VN)
 (74) Công ty TNHH Sở hữu trí tuệ Thảo Thọ Quyến (INVENCO)
 (55)



1.1



1.2



2.1



2.2

- (11) **13037**
(21) 3-2008-00422 (28) 01
(54) THIẾT BỊ NỐI ĐIỆN (51) **13-03**
(22) 27.03.2008 (43) 25.06.2008
(30) 2007-029148 27.09.2007 JP
(71) SMK CORPORATION (JP)
5-5, Togoshi 6-chome, Shinagawa-ku, Tokyo, JAPAN
(72) KOJI HISADA (JP)
(74) Công ty Luật TNHH AMBYS Hà Nội (AMBYS HANOI)
(55)



1.1

1.2

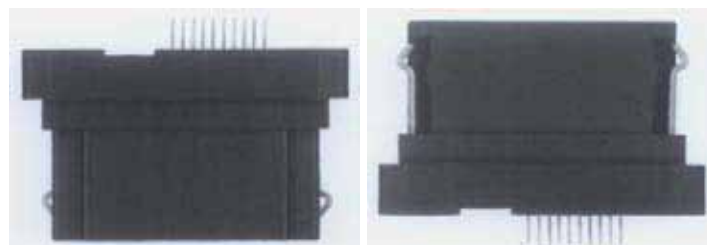

1.3

1.4



1.5

1.6



1.7

1.8

- (11) **13038**
 (21) 3-2008-00429 (28) 01
 (54) BAO GÓI SẢN PHẨM PHÂN BÓN (51) **09-05**
 (22) 27.03.2008 (43) 25.06.2008
 (71) CÔNG TY CỔ PHẦN SINH HÓA MINH ĐỨC (VN)
 Nội Bài, xã Phú Minh, huyện Sóc Sơn, thành phố Hà Nội
 (72) Nguyễn Thanh Đức (VN)
 (55)



1.1

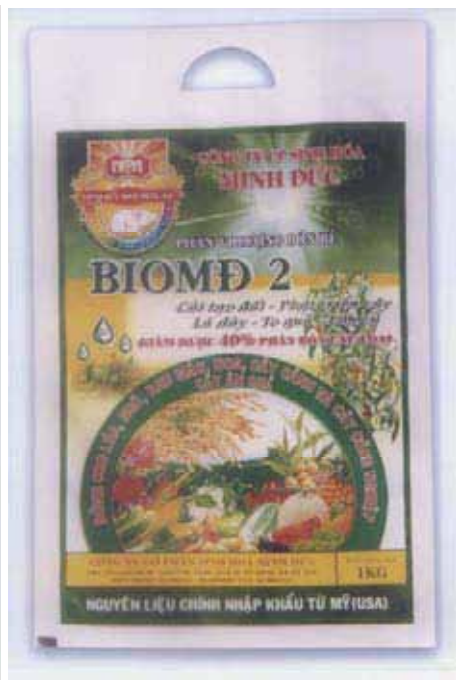

1.2



1.3

- (11) **13039**
 (21) 3-2008-00430 (28) 01
 (54) BAO GÓI SẢN PHẨM PHÂN BÓN (51) **09-05**
 (22) 27.03.2008 (43) 25.06.2008
 (71) CÔNG TY CỔ PHẦN SINH HÓA MINH ĐỨC (VN)
 Nội Bài, xã Phú Minh, huyện Sóc Sơn, thành phố Hà Nội
 (72) Nguyễn Thanh Đức (VN)
 (55)



1.1

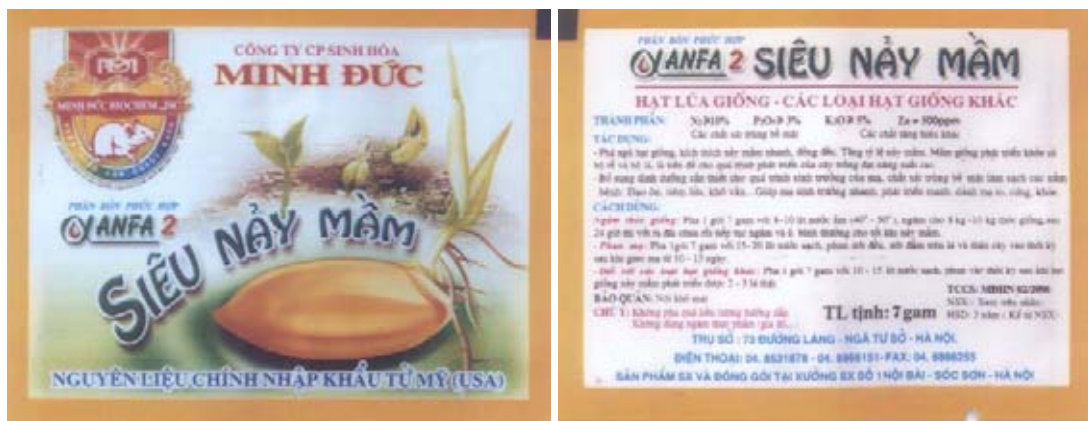

1.2

1.3

- (11) **13040**
(21) 3-2008-00431 (28) 01
(54) VÒI NƯỚC (51) **23-01**
(22) 27.03.2008 (43) 25.06.2008
(71) CÔNG TY TNHH KỸ THUẬT NƯỚC VI NA (VN)
63/18/24 Chu Thiên, phường Hiệp Tân, quận Tân Phú, TP. Hồ Chí Minh
(72) Lương Thị Phượng (VN)
(55)



1.1

1.2



1.3

1.4

1.5

1.6

- (11) **13041**
(21) 3-2008-00433 (28) 03
(54) VÒI NƯỚC (51) **23-01**
(22) 27.03.2008 (43) 25.06.2008
(71) CÔNG TY TNHH KỸ THUẬT NƯỚC VI NA (VN)
63/18/24 Chu Thiên, phường Hiệp Tân, quận Tân Phú, TP. Hồ Chí Minh
(72) Lương Thị Phượng (VN)
(55)



1.1

1.2



1.3

1.4

1.5

1.6



2.1



2.2



2.3



2.4



2.5



2.6



3.1



3.2



3.3



3.4

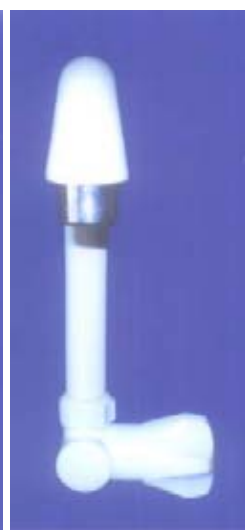

3.5



3.6



3.7

- (11) **13042**
(21) 3-2008-00437 (28) 01
(54) NHÃN SẢN PHẨM (51) **19-08**
(22) 28.03.2008 (43) 25.06.2008
(71) CÔNG TY CỔ PHẦN NƯỚC MẮM PHAN THIẾT (VN)
Đường Nguyễn Thông, phường Phú Hải, thành phố Phan Thiết
(72) Lê Trần Phú Đức (VN)
(74) Văn phòng luật sư Phạm và Liên danh (PHAM & ASSOCIATES)
(55)



1.1



1.2

- (11) **13043**
(21) 3-2008-00438 (28) 01
(54) NHÃN SẢN PHẨM (51) **19-08**
(22) 28.03.2008 (43) 25.06.2008
(71) CÔNG TY CỔ PHẦN NƯỚC MẮM PHAN THIẾT (VN)
Đường Nguyễn Thông, phường Phú Hải, thành phố Phan Thiết
(72) Lê Trần Phú Đức (VN)
(74) Văn phòng luật sư Phạm và Liên danh (PHAM & ASSOCIATES)
(55)



1.1



1.2

- (11) **13044**
(21) 3-2008-00439 (28) 01
(54) NHÃN SẢN PHẨM (51) **19-08**
(22) 28.03.2008 (43) 25.06.2008
(71) CÔNG TY CỔ PHẦN NƯỚC MẮM PHAN THIẾT (VN)
Đường Nguyễn Thông, phường Phú Hải, thành phố Phan Thiết
(72) Lê Trần Phú Đức (VN)
(74) Văn phòng luật sư Phạm và Liên danh (PHAM & ASSOCIATES)
(55)



1.1



1.2

- (11) **13045**
(21) 3-2008-00440 (28) 01
(54) NHÃN SẢN PHẨM (51) **19-08**
(22) 28.03.2008 (43) 25.06.2008
(71) CÔNG TY CỔ PHẦN NƯỚC MẮM PHAN THIẾT (VN)
Đường Nguyễn Thông, phường Phú Hải, thành phố Phan Thiết
(72) Lê Trần Phú Đức (VN)
(74) Văn phòng luật sư Phạm và Liên danh (PHAM & ASSOCIATES)
(55)



1.1



1.2

- (11) **13046**
(21) 3-2008-00442 (28) 01
(54) TẤM THẨM (51) **06-11**
(22) 28.03.2008 (43) 25.06.2008
(71) 1. NARIKO OHARA (KR)
538-18, Ayameikeminami 7-chome, Nara-shi, Nara 631-0033, Japan
2. Kuniaki TAKAMATSU (JP)
34-22, Oaza, Shinchaya, Meiwa-cho, Taki-gun, Mie 515-0314 Japan
(72) Nariko Ohara (KR)
(74) Công ty TNHH Sở hữu trí tuệ WINCO (WINCO CO., LTD.)
(55)



1.1

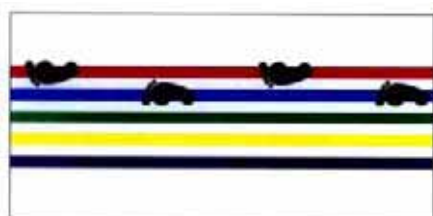

1.2



1.3



1.4



1.5

- (11) **13047**
(21) 3-2008-00443 (28) 01
(54) VÒI NƯỚC (51) **23-01**
(22) 31.03.2008 (43) 25.06.2008
(71) CÔNG TY CỔ PHẦN THIẾT BỊ VỆ SINH CAESAR VIỆT NAM (VN)
Khu công nghiệp Nhơn Trạch 1, huyện Nhơn Trạch, tỉnh Đồng Nai
(72) HSIEH, YU YU (TW)
(74) Công ty TNHH Sở hữu trí tuệ Thảo Thọ Quyển (INVENCO)
(55)



1.1



1.2



1.3



1.4



1.5



1.6

- (11) **13048**
(21) 3-2008-00444 (28) 01
(54) CHAI NHỰA (51) **09-01**
(22) 31.03.2008 (43) 25.06.2008
(71) CÔNG TY TRÁCH NHIỆM HỮU HẠN SẢN XUẤT THƯƠNG MẠI ĐẠI VIỆT
HƯƠNG (VN)
111 Nguyễn Trãi, phường Bến Thành, quận 1, TP. Hồ Chí Minh
(72) Ngô Trung Quân (VN)
(74) Công ty TNHH Sở hữu trí tuệ Thảo Thọ Quyển (INVENCO)
(55)



1.1

1.2

1.3

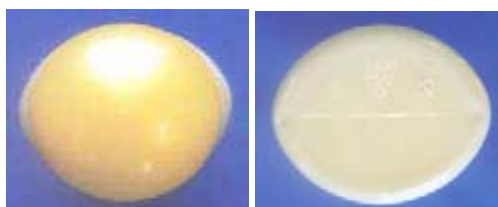

1.4

1.5

- (11) **13049**
(21) 3-2008-00445 (28) 01
(54) CHAI NHỰA (51) **09-01**
(22) 31.03.2008 (43) 25.06.2008
(71) CÔNG TY TRÁCH NHIỆM HỮU HẠN SẢN XUẤT THƯƠNG MẠI ĐẠI VIỆT
HƯƠNG (VN)
111 Nguyễn Trãi, phường Bến Thành, quận 1, TP. Hồ Chí Minh
(72) Ngô Trung Quân (VN)
(74) Công ty TNHH Sở hữu trí tuệ Thảo Thọ Quyến (INVENCO)
(55)



1.1

1.2

1.3



1.4

1.5

- (11) **13050**
(21) 3-2008-00457 (28) 01
(54) ĐỒNG HỒ (51) **10-01**
(22) 31.03.2008 (43) 25.06.2008
(71) CÔNG TY TNHH TRÍ BÌNH (VN)
D16/79 đường Lê Đình Cẩn, khu phố 6, phường Tân Tạo, quận Bình Tân, TP. Hồ Chí Minh
(72) Huỳnh Minh Tân (VN)
(74) Công ty TNHH Sở hữu trí tuệ WINCO (WINCO CO., LTD.)
(55)



1.1

1.2

1.3

1.4



1.5

1.6

- (11) **13051**
(21) 3-2008-00459 (28) 01
(54) NHÃN SẢN PHẨM (51) **19-08**
(22) 31.03.2008 (43) 25.06.2008
(71) CÔNG TY CỔ PHẦN SINH HÓA MINH ĐỨC (VN)
Nội Bài, xã Phú Minh, huyện Sóc Sơn, thành phố Hà Nội
(72) Nguyễn Thanh Đức (VN)
(55)



- (11) **13052**
(21) 3-2008-00460 (28) 01
(54) NHÃN SẢN PHẨM (51) **19-08**
(22) 31.03.2008 (43) 25.06.2008
(71) CÔNG TY CỔ PHẦN SINH HÓA MINH ĐỨC (VN)
Nội Bài, xã Phú Minh, huyện Sóc Sơn, thành phố Hà Nội
(72) Nguyễn Thanh Đức (VN)
(55)



- (11) **13053**
(21) 3-2008-00461 (28) 01
(54) NHÃN SẢN PHẨM (51) **19-08**
(22) 31.03.2008 (43) 25.06.2008
(71) CÔNG TY CỔ PHẦN SINH HÓA MINH ĐỨC (VN)
Nội Bài, xã Phú Minh, huyện Sóc Sơn, thành phố Hà Nội
(72) Nguyễn Thanh Đức (VN)
(55)



- (11) **13054**
(21) 3-2008-00462 (28) 01
(54) GHẾ (51) **06-01**
(22) 01.04.2008 (43) 25.06.2008
(71) CÔNG TY TRÁCH NHIỆM HỮU HẠN MỘT THÀNH VIÊN THƯƠNG MẠI VIỆT
ĐẠI THÀNH (VN)
393 Xô Viết Nghệ Tĩnh, phường 24, quận Bình Thạnh, TP. Hồ Chí Minh
(72) Chokchai Charoenapornwatana (TH)
(74) Công ty TNHH một thành viên Trường Luật (CÔNG TY TRUONG LUAT)
(55)

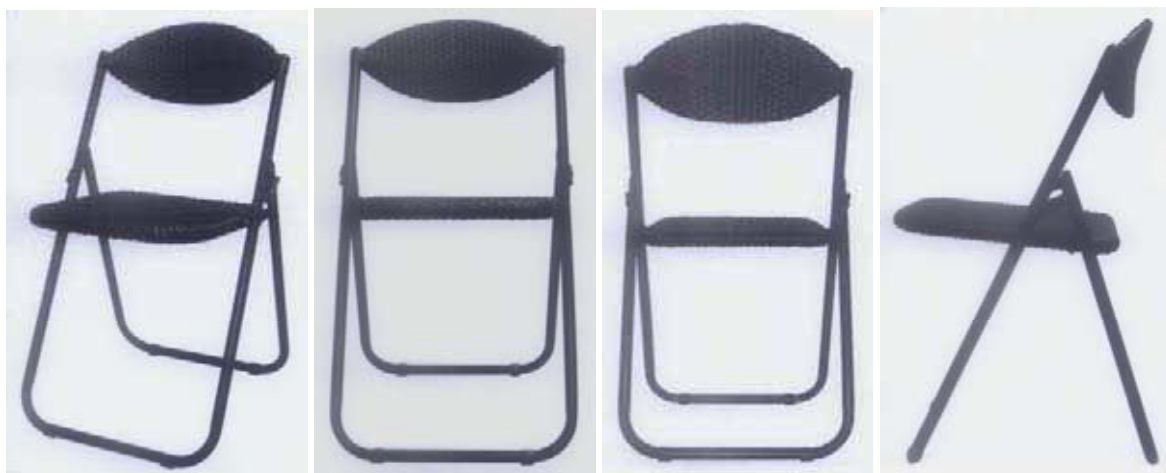

1.1

1.2

1.3

1.4



1.5

1.6

CÔNG BÁO SỞ HỮU CÔNG NGHIỆP SỐ 243 TẬP A (06.2008)

- | | | | |
|------|--|------|--------------|
| (11) | 13055 | | |
| (21) | 3-2008-00463 | (28) | 01 |
| (54) | NHÃN SẢN PHẨM | (51) | 19-08 |
| (22) | 01.04.2008 | (43) | 25.06.2008 |
| (71) | CÔNG TY CỔ PHẦN TÂN TẤN PHÁT (VN)
170 Nguyễn Trung Trực, phường Vĩnh Bảo, thành phố Rạch Giá, tỉnh Kiên Giang | | |
| (72) | Hà Chí Dũng (VN) | | |
| (74) | Công ty TNHH Sở hữu trí tuệ Bình Minh (SUNRISE IP CO.,LTD.) | | |
| (55) | | | |



- (11) **13056**
(21) 3-2008-00468 (28) 01
(54) ÁO MƯA (51) **02-02**
(22) 01.04.2008 (43) 25.06.2008
(71) CÔNG TY TNHH XÂY DỰNG - THƯƠNG MẠI - DỊCH VỤ - SẢN XUẤT - XUẤT
NHẬP KHẨU QUANG VINH (VN)
2900 Phạm Thế Hiển, phường 7, quận 8, TP. Hồ Chí Minh
(72) Lê Thị Thu Nga (VN)
(74) Công ty Cổ phần Sở hữu công nghiệp INVESTIP (INVESTIP)
(55)



1.1



1.2



1.3

- (11) **13057**
(21) 3-2008-00481 (28) 01
(54) HỘ ĐUNG SẢN PHẨM (51) **09-03**
(22) 04.04.2008 (43) 25.06.2008
(71) CÔNG TY LIÊN DOANH TNHH HẢI HÀ - KOTOBUKI (VN)
25 Trương Định, quận Hai Bà Trưng, thành phố Hà Nội
(72) Doãn Minh Dũng (VN)
(74) Văn phòng luật sư Phạm và Liên danh (PHAM & ASSOCIATES)
(55)



1.1



1.2



1.3



1.4



1.5



1.6



1.7

- (11) **13058**
(21) 3-2008-00486 (28) 03
(54) BAO GÓI (51) **09-05**
(22) 04.04.2008 (43) 25.06.2008
(71) CÔNG TY CỔ PHẦN ACECOOK VIỆT NAM (VN)
Lô II-3, đường 11, KCN Tân Bình, phường Tây Thạnh, quận Tân Phú, TP. Hồ Chí Minh
(72) Hoàng Cao Trí (VN)
(74) Văn phòng luật sư Phạm và Liên danh (PHAM & ASSOCIATES)
(55)

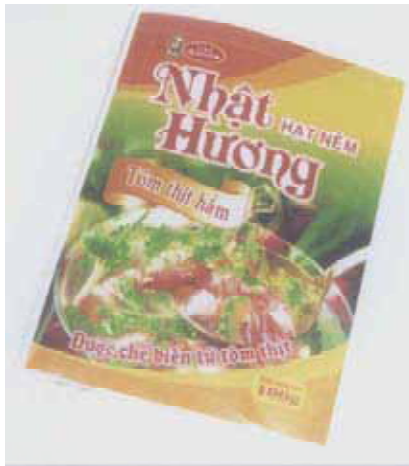

1.1



1.2



2.1



2.2



3.1

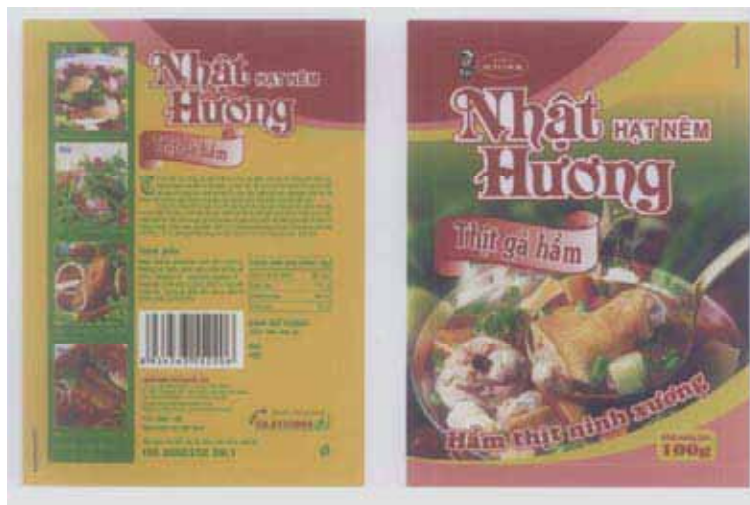

3.2

- (11) **13059**
(21) 3-2008-00488 (28) 01
(54) BAO GÓI (51) **09-05**
(22) 07.04.2008 (43) 25.06.2008
(71) CÔNG TY CỔ PHẦN VINA CAFÉ BIÊN HÒA (VN)
Khu công nghiệp Biên Hoà 1, tỉnh Đồng Nai
(72) Bùi Xuân Thoa (VN)
(74) Công ty TNHH Sở hữu trí tuệ Thảo Thọ Quyến (INVENCO)
(55)



1.1



1.2

- (11) **13060**
(21) 3-2008-00489 (28) 01
(54) HỘP (51) **09-03**
(22) 07.04.2008 (43) 25.06.2008
(71) CÔNG TY CỔ PHẦN VINA CAFÉ BIÊN HÒA (VN)
Khu công nghiệp Biên Hoà 1, tỉnh Đồng Nai
(72) Bùi Xuân Thoa (VN)
(74) Công ty TNHH Sở hữu trí tuệ Thảo Thọ Quyến (INVENCO)
(55)

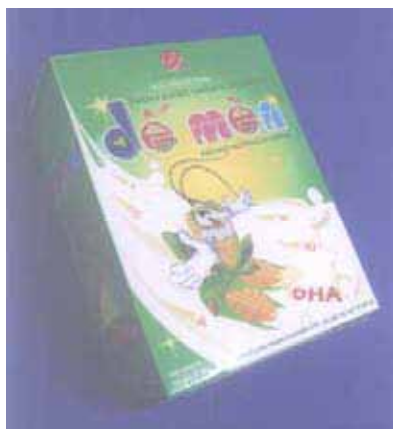

1.1



1.2

- (11) **13061**
(21) 3-2008-00490 (28) 01
(54) BAO GÓI MIẾN (51) **09-05**
(22) 07.04.2008 (43) 25.06.2008
(71) CÔNG TY CỔ PHẦN LƯƠNG THỰC THỰC PHẨM COLUSA - MILIKET (VN)
1230 Kha Vạn Cân, phường Linh Trung, quận Thủ Đức, TP. Hồ Chí Minh
(72) Võ Văn út (VN)
(74) Công ty Cổ phần Sở hữu công nghiệp INVESTIP (INVESTIP)
(55)



1.1



1.2

- (11) **13062**
(21) 3-2008-00491 (28) 01
(54) BAO GÓI MIẾN (51) **09-05**
(22) 07.04.2008 (43) 25.06.2008
(71) CÔNG TY CỔ PHẦN LƯƠNG THỰC THỰC PHẨM COLUSA - MILIKET (VN)
1230 Kha Vạn Cân, phường Linh Trung, quận Thủ Đức, TP. Hồ Chí Minh
(72) Võ Văn út (VN)
(74) Công ty Cổ phần Sở hữu công nghiệp INVESTIP (INVESTIP)
(55)



1.1



1.2

- (11) **13063**
(21) 3-2008-00492 (28) 01
(54) THANH NHÔM (51) **25-01**
(22) 08.04.2008 (43) 25.06.2008
(71) CÔNG TY TNHH THƯƠNG MẠI VÀ XÂY DỰNG ĐỨC HẠNH (VN)
Số 297, ngõ Văn Chương, phường Văn Chương, quận Đống Đa, thành phố Hà Nội
(72) Lê Duy Đức (VN)
(55)



1.1

1.2

1.3

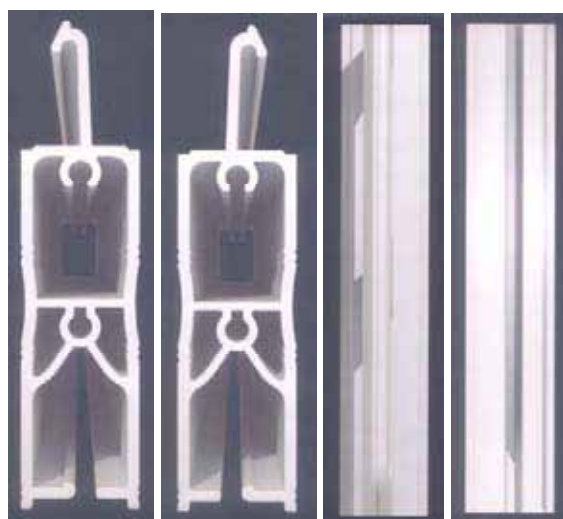

1.4

1.5

1.6

1.7

- (11) **13064**
(21) 3-2008-00498 (28) 01
(54) MÁY KỂ CHUYỆN (51) **14-03**
(22) 08.04.2008 (43) 25.06.2008
(71) CÔNG TY TNHH ĐẦU TƯ - THƯƠNG MẠI TÂM NHẬT MINH (VN)
158D Trần Quang Khải, phường Tân Định, quận 1, TP. Hồ Chí Minh
(72) Bùi Nữ Thục Vy (VN)
(74) Công ty TNHH Sở hữu trí tuệ WINCO (WINCO CO., LTD.)
(55)



1.1



1.2



1.3



1.4



1.5



1.6



1.7

- (11) **13065**
(21) 3-2008-00499 (28) 02
(54) XE Ô TÔ (51) **12-08**
(22) 08.04.2008 (43) 25.06.2008
(30) 2007-027544 09.10.2007 JP
2007-027546 09.10.2007 JP
(71) TOYOTA JIDOSHA KABUSHIKI KAISHA (JP)
1, Toyota-cho, Toyota-shi, Aichi-ken 471-8571, Japan
(72) Masanari SAKAE (JP), Hiroyuki TADA (JP), Shinno KATO (JP), Tokiko GAMOU (JP)
(74) Công ty TNHH Quốc tế D & N (D&N INTERNATIONAL CO.,LTD.)
(55)



1.1



1.2



1.3



1.4



1.5



1.6



2.1



2.2



2.3

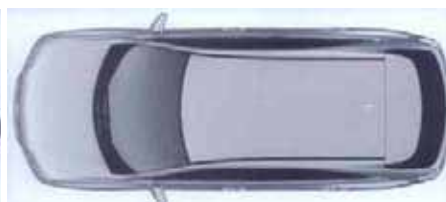

2.4



2.5



2.6

- (11) **13066**
(21) 3-2008-00500
(54) HỘP THUỐC
(22) 09.04.2008
(71) CÔNG TY TNHH THƯƠNG MẠI VÀ DƯỢC PHẨM HUNG VIỆT (VN)
P10/ A1 tập thể Nghĩa Tân, Cầu Giấy, thành phố Hà Nội
(72) Phùng Quang Minh (VN)
(74) Công ty TNHH Sở hữu trí tuệ Sao Việt (VIPAT CO., LTD.)
(55)
- (28) 01
(51) **09-03**
(43) 25.06.2008



1.1



1.2

- (11) **13067**
 (21) 3-2008-00501
 (54) HỘP THUỐC
 (22) 09.04.2008
 (71) CÔNG TY TNHH THƯƠNG MẠI VÀ DƯỢC PHẨM HUNG VIỆT (VN)
 P10/ A1 tập thể Nghĩa Tân, Cầu Giấy, thành phố Hà Nội
 (72) Phùng Quang Minh (VN)
 (74) Công ty TNHH Sở hữu trí tuệ Sao Việt (VIPAT CO., LTD.)
 (55)



1.1



1.2

- (11) **13068**
(21) 3-2008-00502 (28) 01
(54) BAO GÓI BÁNH SNACK (51) **09-05**
(22) 09.04.2008 (43) 25.06.2008
(71) CÔNG TY CỔ PHẦN THƯƠNG MẠI VÀ DỊCH VỤ THIÊN ĐỨC (VN)
Cụm công nghiệp thực phẩm Hapro, xã Lệ Chi, huyện Gia Lâm, thành phố Hà Nội
(72) Vũ Văn Quang (VN)
(55)



1.1



1.2

- (11) **13069**
(21) 3-2008-00503 (28) 01
(54) BAO GÓI BÁNH SNACK (51) **09-05**
(22) 09.04.2008 (43) 25.06.2008
(71) CÔNG TY CỔ PHẦN THƯƠNG MẠI VÀ DỊCH VỤ THIÊN ĐỨC (VN)
Cụm công nghiệp thực phẩm Hapro, xã Lệ Chi, huyện Gia Lâm, thành phố Hà Nội
(72) Vũ Văn Quang (VN)
(55)



1.1



1.2

- (11) **13070**
(21) 3-2008-00504 (28) 01
(54) BAO GÓI BÁNH SNACK (51) **09-05**
(22) 09.04.2008 (43) 25.06.2008
(71) CÔNG TY CỔ PHẦN THƯƠNG MẠI VÀ DỊCH VỤ THIÊN ĐỨC (VN)
Cụm công nghiệp thực phẩm Hapro, xã Lệ Chi, huyện Gia Lâm, thành phố Hà Nội
(72) Vũ Văn Quang (VN)
(55)



1.1



1.2

- (11) **13071**
(21) 3-2008-00505 (28) 01
(54) BAO GÓI BÁNH SNACK (51) **09-05**
(22) 09.04.2008 (43) 25.06.2008
(71) CÔNG TY CỔ PHẦN THƯƠNG MẠI VÀ DỊCH VỤ THIÊN ĐỨC (VN)
Cụm công nghiệp thực phẩm Hapro, xã Lệ Chi, huyện Gia Lâm, thành phố Hà Nội
(72) Vũ Văn Quang (VN)
(55)



1.1



1.2

- (11) **13072**
(21) 3-2008-00506 (28) 01
(54) BAO GÓI BÁNH SNACK (51) **09-05**
(22) 09.04.2008 (43) 25.06.2008
(71) CÔNG TY CỔ PHẦN THƯƠNG MẠI VÀ DỊCH VỤ THIÊN ĐỨC (VN)
Cụm công nghiệp thực phẩm Hapro, xã Lệ Chi, huyện Gia Lâm, thành phố Hà Nội
(72) Vũ Văn Quang (VN)
(55)



1.1



1.2

- (11) **13073**
(21) 3-2008-00507 (28) 01
(54) BAO GÓI BÁNH SNACK (51) **09-05**
(22) 09.04.2008 (43) 25.06.2008
(71) CÔNG TY CỔ PHẦN THƯƠNG MẠI VÀ DỊCH VỤ THIÊN ĐỨC (VN)
Cụm công nghiệp thực phẩm Hapro, xã Lệ Chi, huyện Gia Lâm, thành phố Hà Nội
(72) Vũ Văn Quang (VN)
(55)



1.1



1.2

- (11) **13074**
(21) 3-2008-00508 (28) 01
(54) BAO GÓI BÁNH SNACK (51) **09-05**
(22) 09.04.2008 (43) 25.06.2008
(71) CÔNG TY CỔ PHẦN THƯƠNG MẠI VÀ DỊCH VỤ THIÊN ĐỨC (VN)
Cụm công nghiệp thực phẩm Hapro, xã Lệ Chi, huyện Gia Lâm, thành phố Hà Nội
(72) Vũ Văn Quang (VN)
(55)



1.1

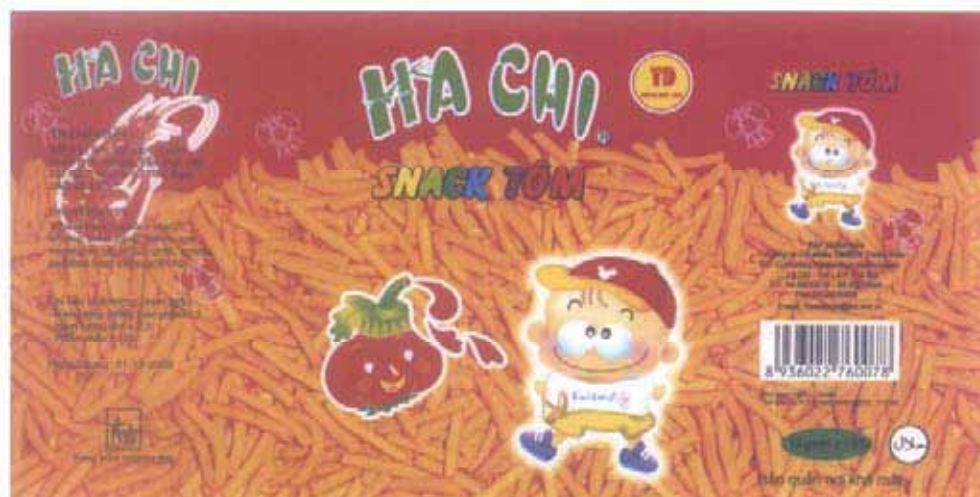

1.2

- (11) **13075**
(21) 3-2008-00509 (28) 01
(54) BAO GÓI BÁNH SNACK (51) **09-05**
(22) 09.04.2008 (43) 25.06.2008
(71) CÔNG TY CỔ PHẦN THƯƠNG MẠI VÀ DỊCH VỤ THIÊN ĐỨC (VN)
Cụm công nghiệp thực phẩm Hapro, xã Lệ Chi, huyện Gia Lâm, thành phố Hà Nội
(72) Vũ Văn Quang (VN)
(55)



1.1

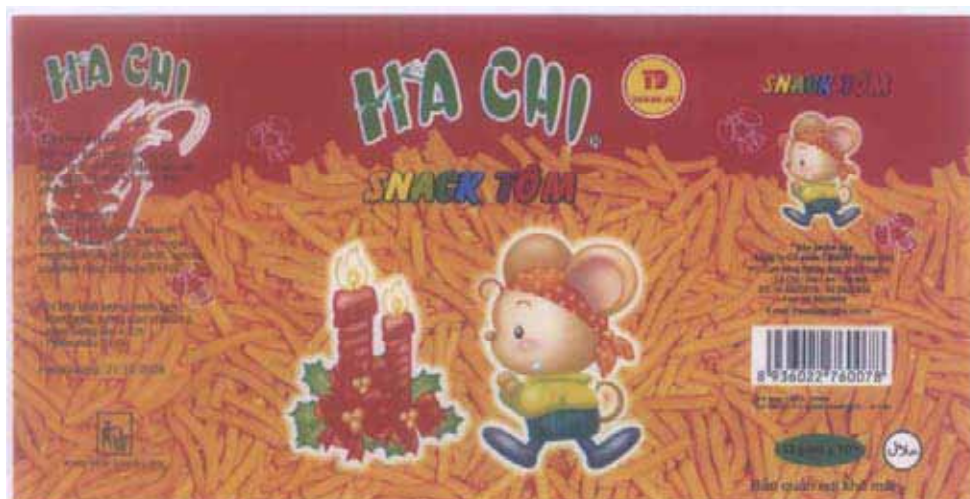

1.2

- (11) **13076**
(21) 3-2008-00511 (28) 01
(54) KHÓA ĐIỀU CHỈNH DÂY (51) **02-07**
(22) 09.04.2008 (43) 25.06.2008
(30) 96306327 20.11.2007 TW
(71) NIFCO TAIWAN CORPORATION (TW)
7th Floor, China General Plastic Bldg. No. 3, Tun-Hwa S. Road., Sec. 1, Taipei
(72) CHANG, PEI-HSUAN (TW)
(74) Công ty TNHH Sở hữu trí tuệ Thảo Thọ Quyển (INVENCO)
(55)

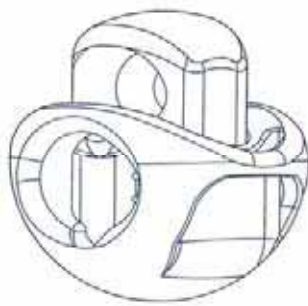

1.1

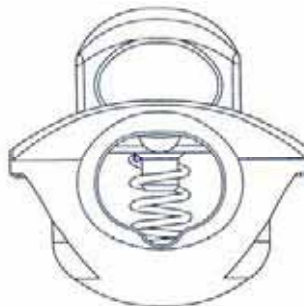

1.2

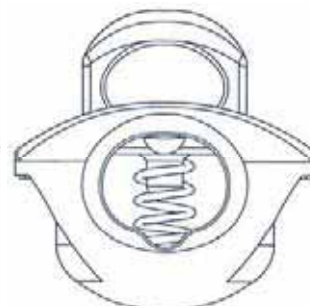

1.3

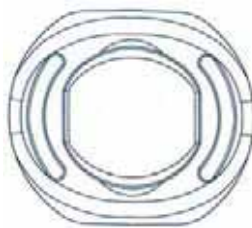

1.4

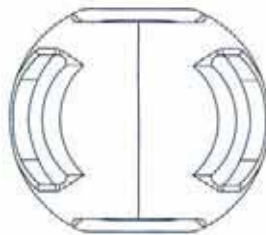

1.5



1.6

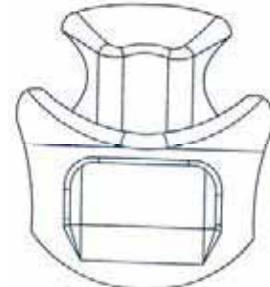

1.7

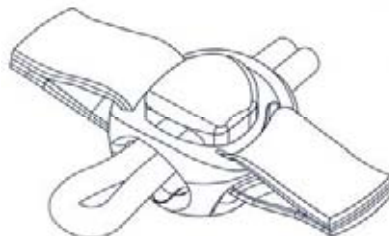

1.8

- (11) **13077**
(21) 3-2008-00512 (28) 01
(54) THÙNG (51) **09-02**
(22) 09.04.2008 (43) 25.06.2008
(30) 29/295921 10.10.2007 US
(71) ABBOTT LABORATORIES (US)
Dept. 377 Bldg AP6A-1, 100 Abbott Park Road, Abbott Park, Illinois 60064-6008, USA
(72) James P. Perry (US), Craig A. McCardell (US), Jeremy McBroom (CA), David Compeau (US), Ashley A. Gohlke (US), William J. Hook (US), Katherine J. Jordan (US), Frank S. Walczak (CA), Peter B. Clarke (US), J. Kevin Clay (US)
(74) Công ty TNHH Sở hữu trí tuệ Thảo Thọ Quyển (INVENCO)
(55)



1.1



1.2



1.3

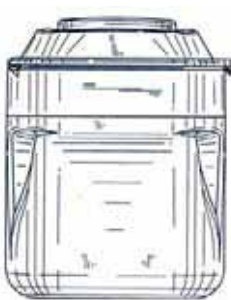

1.4

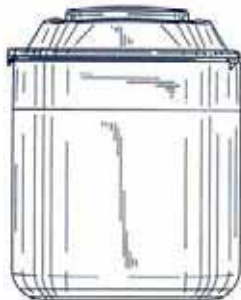

1.5



1.6



1.7

- (11) **13078**
(21) 3-2008-00513 (28) 01
(54) THÙNG (51) **09-02**
(22) 09.04.2008 (43) 25.06.2008
(30) 29/295921 10.10.2007 US
29/299729 03.01.2008 US
(71) ABBOTT LABORATORIES (US)
Dept. 377 Bldg AP6A-1, 100 Abbott Park Road, Abbott Park, Illinois 60064-6008, USA
(72) James P. Perry (US), Ashley A. Gohlke (US), William J. Hook (US), Katherine J. Jordan
(US), Frank S. Walczak (CA), Peter B. Clarke (US), J. Kevin Clay (US)
(74) Công ty TNHH Sở hữu trí tuệ Thảo Thọ Quyển (INVENCO)
(55)

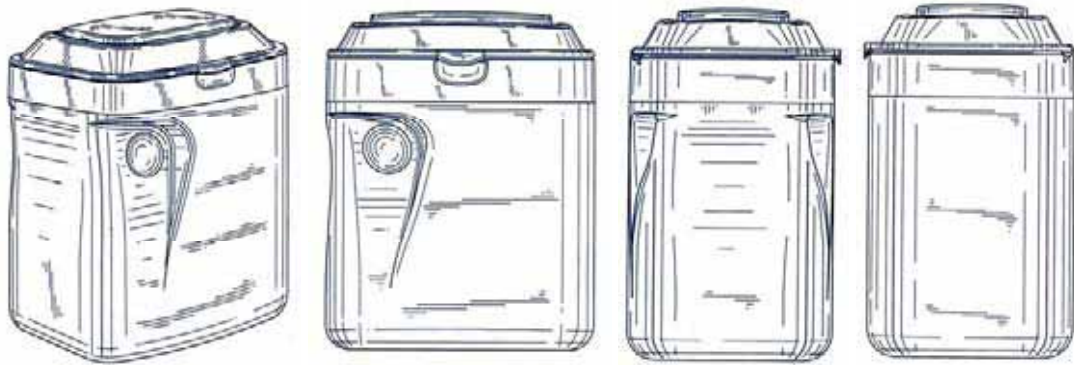

1.1

1.2

1.3

1.4

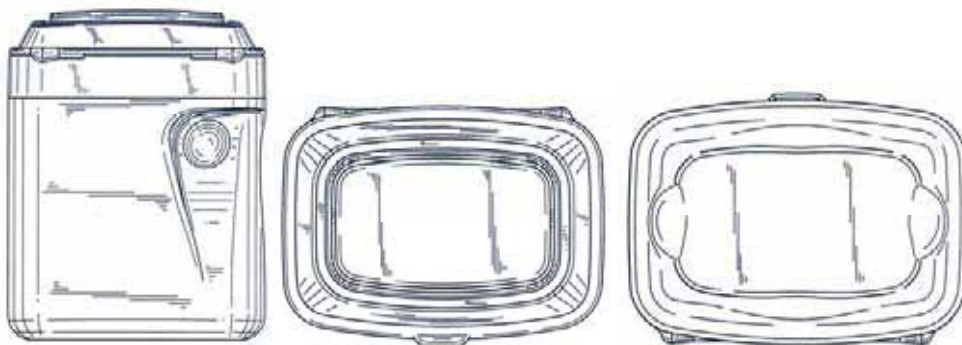

1.5

1.6

1.7

- (11) **13079**
(21) 3-2008-00515 (28) 04
(54) NHÃN SẢN PHẨM (51) **19-08**
(22) 09.04.2008 (43) 25.06.2008
(71) CÔNG TY CỔ PHẦN THỰC PHẨM QUỐC TẾ (VN)
Lô 13, khu công nghiệp Tam Phước, Long Thành, tỉnh Đồng Nai
(72) CHEN TUCK BOON (MY)
(74) Công ty TNHH Sở hữu trí tuệ WINCO (WINCO CO., LTD.)
(55)



1



2



3



4

- (11) **13080**
(21) 3-2008-00516 (28) 01
(54) HỘP ĐỰNG THUỐC (51) **09-03**
(22) 10.04.2008 (43) 25.06.2008
(71) CÔNG TY CỔ PHẦN DƯỢC TW MEDIPLANTEX (VN)
358 đường Giải Phóng, phường Phương Liệt, quận Thanh Xuân, thành phố Hà Nội
(72) Trần Bình Duyên (VN)
(74) Công ty TNHH Sở hữu trí tuệ PADEMARK (PADEMARK CO.,LTD.)
(55)



1.1



1.2

- (11) **13081**
(21) 3-2008-00517 (28) 01
(54) HỘP ĐỰNG THUỐC (51) **09-03**
(22) 10.04.2008 (43) 25.06.2008
(71) CÔNG TY CỔ PHẦN DƯỢC TW MEDIPLANTEX (VN)
358 đường Giải Phóng, phường Phương Liệt, quận Thanh Xuân, thành phố Hà Nội
(72) Trần Bình Duyên (VN)
(74) Công ty TNHH Sở hữu trí tuệ PADEMARK (PADEMARK CO.,LTD.)
(55)



1.1



1.2

- (11) **13082**
(21) 3-2008-00518 (28) 01
(54) HỘP ĐỰNG THUỐC (51) **09-03**
(22) 10.04.2008 (43) 25.06.2008
(71) CÔNG TY CỔ PHẦN DƯỢC TW MEDIPLANTEX (VN)
358 đường Giải Phóng, phường Phương Liệt, quận Thanh Xuân, thành phố Hà Nội
(72) Trần Bình Duyên (VN)
(74) Công ty TNHH Sở hữu trí tuệ PADEMARK (PADEMARK CO.,LTD.)
(55)



1.1



1.2

- (11) **13083**
(21) 3-2008-00519 (28) 01
(54) HỘP ĐỰNG THUỐC (51) **09-03**
(22) 10.04.2008 (43) 25.06.2008
(71) CÔNG TY CỔ PHẦN DƯỢC TW MEDIPLANTEX (VN)
358 đường Giải Phóng, phường Phương Liệt, quận Thanh Xuân, thành phố Hà Nội
(72) Trần Bình Duyên (VN)
(74) Công ty TNHH Sở hữu trí tuệ PADEMARK (PADEMARK CO.,LTD.)
(55)



1.1



1.2

- (11) **13084**
(21) 3-2008-00520 (28) 01
(54) LỢ (51) **09-01**
(22) 11.04.2008 (43) 25.06.2008
(71) SUPON CHAISATAPORN (TH)
99/99 Moo7, Sukhapibal 2 Road, Om-Noi, Krathumban, Samut Sakhon 74130, Thailand
(72) Supon Chaisataporn (TH)
(74) Công ty TNHH Tâm nhìn và Liên danh (VISION & ASSOCIATES CO.LTD.)
(55)

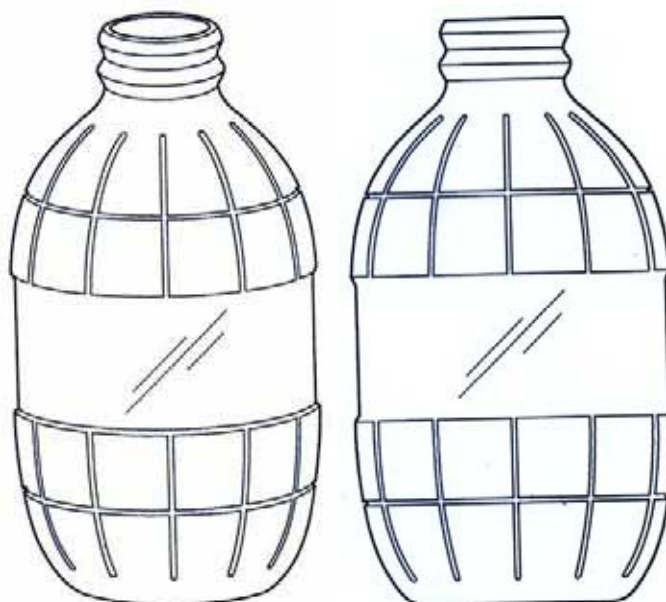

1.1

1.2

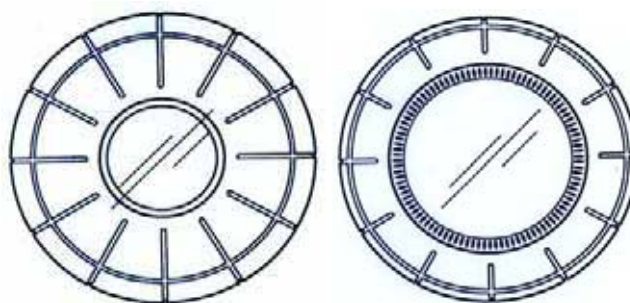

1.3

1.4

- (11) **13085**
(21) 3-2008-00521 (28) 01
(54) LỢ (51) **09-01**
(22) 11.04.2008 (43) 25.06.2008
(71) SUPON CHAISATAPORN (TH)
99/99 Moo7, Sukhapibal 2 Road, Om-Noi, Krathumban, Samut Sakhon 74130, Thailand
(72) Supon Chaisataporn (TH)
(74) Công ty TNHH Tâm nhìn và Liên danh (VISION & ASSOCIATES CO.LTD.)
(55)



1.1

1.2

1.3

1.4

1.5

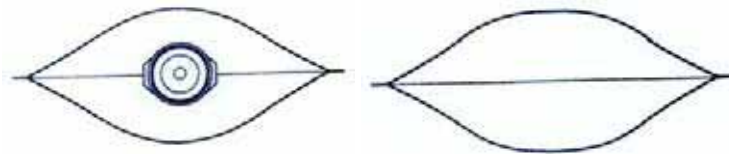

1.6

1.7

- (11) **13086**
(21) 3-2008-00523 (28) 01
(54) GHẾ NHỰA (51) **06-01**
(22) 11.04.2008 (43) 25.06.2008
(71) CÔNG TY CỔ PHẦN ĐẠI ĐỒNG TIẾN (VN)
216 Tân Thành, phường 15, quận 5, TP. Hồ Chí Minh
(72) Trịnh Đồng (VN)
(74) DNTN Dịch vụ thương mại và sở hữu công nghiệp Song Ngọc (I.P.T.S.)
(55)

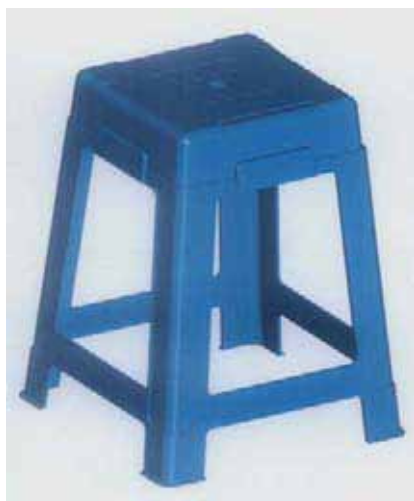

1.1

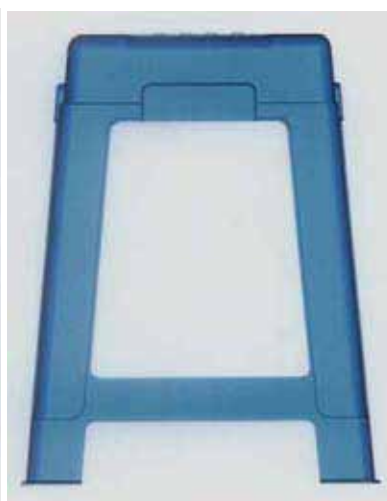

1.2

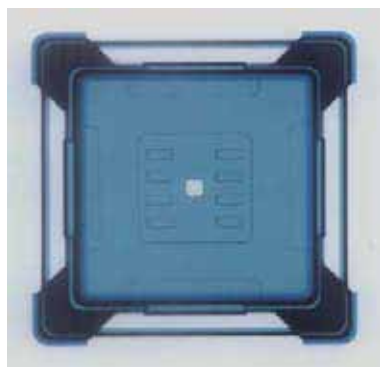

1.3

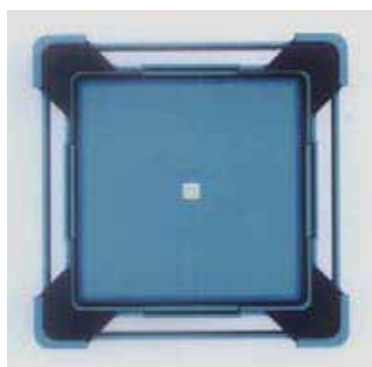

1.4

- (11) **13087**
(21) 3-2008-00524 (28) 01
(54) BÌNH NHỰA (51) **07-07**
(22) 11.04.2008 (43) 25.06.2008
(71) CÔNG TY CỔ PHẦN ĐẠI ĐỒNG TIẾN (VN)
216 Tân Thành, phường 15, quận 5, TP. Hồ Chí Minh
(72) Trịnh Đồng (VN)
(74) DNTN Dịch vụ thương mại và sở hữu công nghiệp Song Ngọc (I.P.T.S.)
(55)



1.1

1.2

1.3

1.4

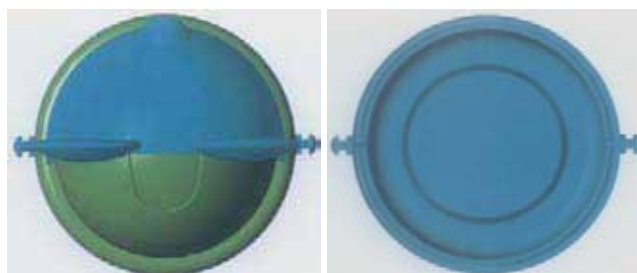

1.5

1.6

(11) **13088**

(21) 3-2008-00525

(54) VÒI NƯỚC

(22) 11.04.2008

(71) CÔNG TY TNHH ĐẠI ÁNH SÁNG (VN)

Lô số 17, khu công nghiệp Tân Tạo, đường Tân Tạo, phường Tân Tạo A, quận Bình Tân, TP. Hồ Chí Minh

(72) Vương Diệu Tinh (VN)

(74) DNTN Dịch vụ thương mại và sở hữu công nghiệp Song Ngọc (I.P.T.S.)

(55)

(28) 01

(51) **23-01**

(43) 25.06.2008



1.1

1.2

1.3

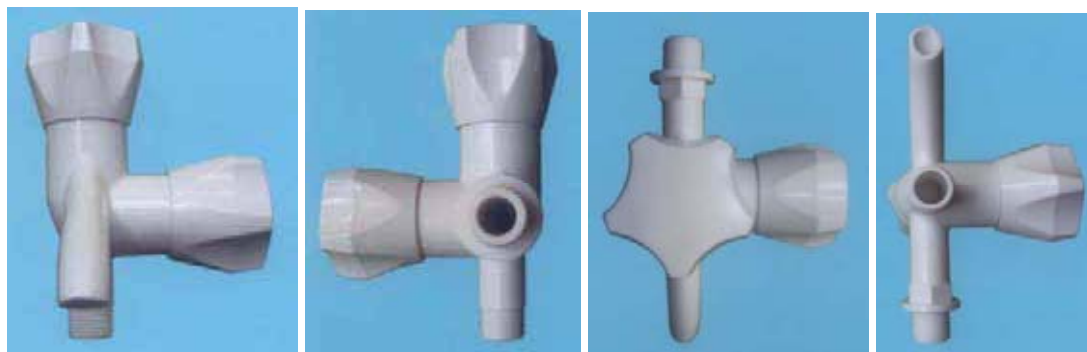

1.4

1.5

1.6

1.7

- (11) **13089**
(21) 3-2008-00526 (28) 01
(54) CHAI (51) **09-01**
(22) 14.04.2008 (43) 25.06.2008
(30) 200730320275.4 26.10.2007 CN
(71) THE COCA-COLA COMPANY (US)
One Coca-Cola Plaza, NW, Atlanta, Georgia 30313, United States of America
(72) Wing AU-YEUNG (GB), Zhe Yu CHEN (CN), Jun Hua XU (CN)
(74) Văn phòng Luật sư Đoàn Hồng Sơn (VPLS DOANHONGSON)
(55)

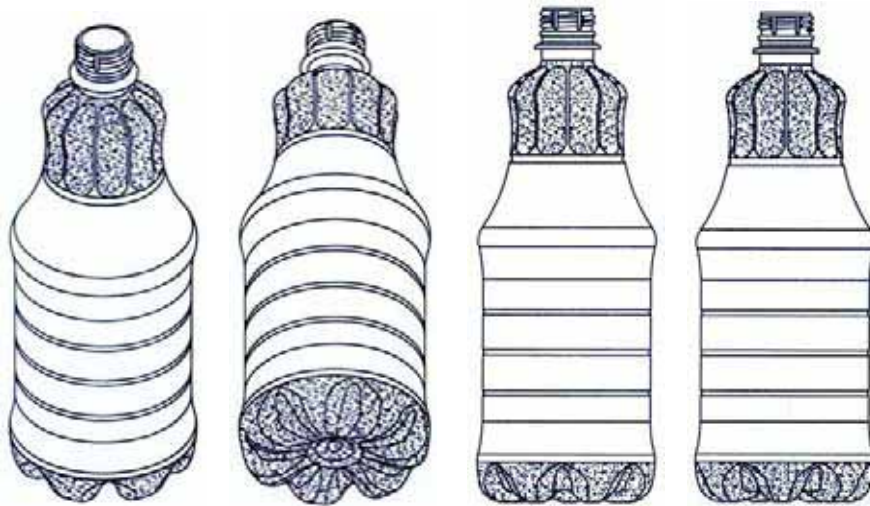

1.1

1.2

1.3

1.4

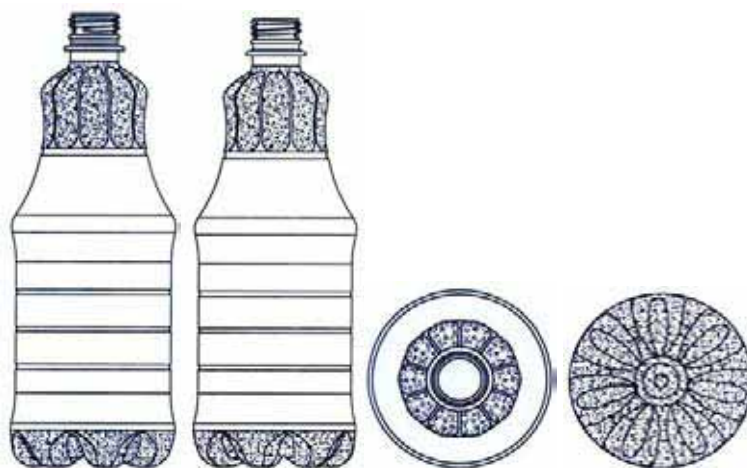

1.5

1.6

1.7

1.8

- (11) **13090**
(21) 3-2008-00527 (28) 01
(54) TẤM LÓT NÓN BẢO HIỂM (51) **02-03**
(22) 14.04.2008 (43) 25.06.2008
(71) CÔNG TY TNHH THỜI TRANG NÓN SƠN (VN)
94 Nguyễn Thị Minh Khai, phường 6, quận 3, TP. Hồ Chí Minh
(72) Trần Anh Sơn (VN)
(74) Công ty Cổ phần Sở hữu công nghiệp INVESTIP (INVESTIP)
(55)



1.1



1.2



1.3

- (11) **13091**
(21) 3-2008-00531 (28) 01
(54) HỘP (51) **09-03**
(22) 16.04.2008 (43) 25.06.2008
(30) 30-2007-0044093 24.10.2007 KR
(71) LOCK & LOCK COMPANY LIMITED (KR)
Lock&Lock Bldg. 1556-1, Seocho-3 Dong, Seocho-gu, Seoul, Korea
(72) Kim Chang Ho (KR)
(74) Công ty TNHH Tầm nhìn và Liên danh (VISION & ASSOCIATES CO.LTD.)
(55)

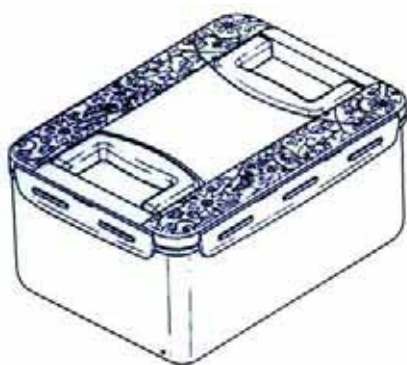

1.1

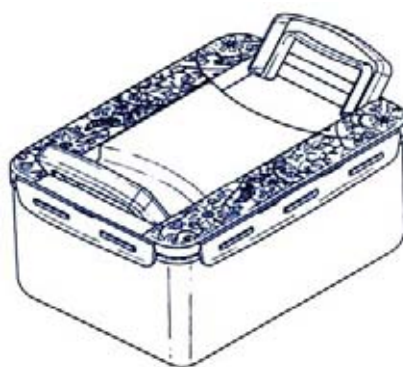

1.2

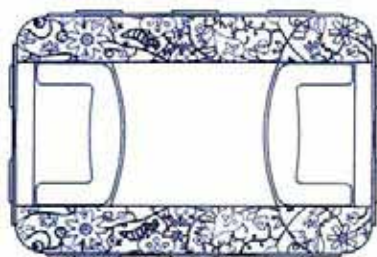

1.3



1.4

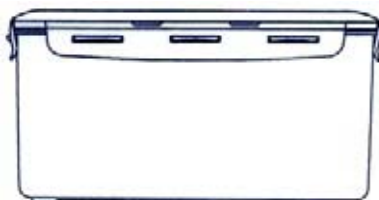

1.5



1.6

- (11) **13092**
(21) 3-2008-00533 (28) 02
(54) HỘP (51) **09-03**
(22) 17.04.2008 (43) 25.06.2008
(71) CÔNG TY TRÁCH NHIỆM HỮU HẠN THƯƠNG MẠI VÀ DỊCH VỤ K & H (VN)
Lô 5 đường Nước Lên, khu công nghiệp Tân Tạo, quận Bình Tân, TP. Hồ Chí Minh
(72) Nguyễn Thiên Hương (VN)
(74) Công ty TNHH Sở hữu trí tuệ Thảo Thọ Quyến (INVENCO)
(55)

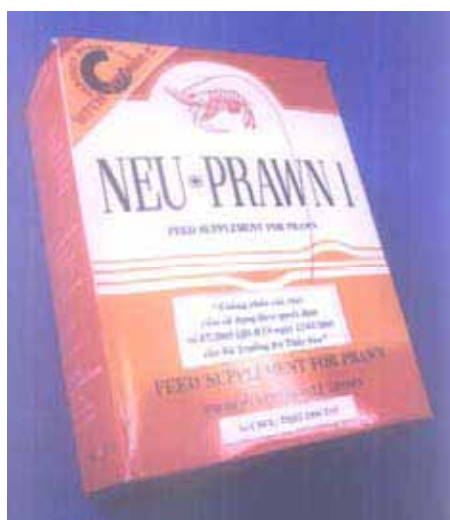

1.1



1.2

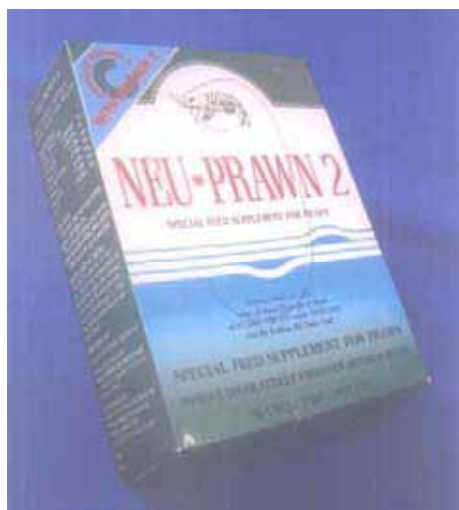

2.1



2.2

- (11) **13093**
(21) 3-2008-00534 (28) 01
(54) BAO GÓI (51) **09-05**
(22) 17.04.2008 (43) 25.06.2008
(71) CÔNG TY TRÁCH NHIỆM HỮU HẠN THƯƠNG MẠI VÀ DỊCH VỤ K & H (VN)
Lô 5 đường Nước Lên, khu công nghiệp Tân Tạo, quận Bình Tân, TP. Hồ Chí Minh
(72) Nguyễn Thiên Hương (VN)
(74) Công ty TNHH Sở hữu trí tuệ Thảo Thọ Quyến (INVENCO)
(55)



1.1



1.2

- (11) **13094**
(21) 3-2008-00535 (28) 01
(54) NHÃN SẢN PHẨM (51) **19-08**
(22) 17.04.2008 (43) 25.06.2008
(71) CÔNG TY TRÁCH NHIỆM HỮU HẠN THƯƠNG MẠI VÀ DỊCH VỤ K & H (VN)
Lô 5 đường Nước Lên, khu công nghiệp Tân Tạo, quận Bình Tân, TP. Hồ Chí Minh
(72) Nguyễn Thiên Hương (VN)
(74) Công ty TNHH Sở hữu trí tuệ Thảo Thọ Quyến (INVENCO)
(55)



1.1



1.2

- (11) **13095**
(21) 3-2008-00536 (28) 01
(54) BAO GÓI (51) **09-05**
(22) 17.04.2008 (43) 25.06.2008
(71) CÔNG TY TRÁCH NHIỆM HỮU HẠN THƯƠNG MẠI VÀ DỊCH VỤ K & H (VN)
Lô 5 đường Nước Lên, khu công nghiệp Tân Tạo, quận Bình Tân, TP. Hồ Chí Minh
(72) Nguyễn Thiên Hương (VN)
(74) Công ty TNHH Sở hữu trí tuệ Thảo Thọ Quyến (INVENCO)
(55)

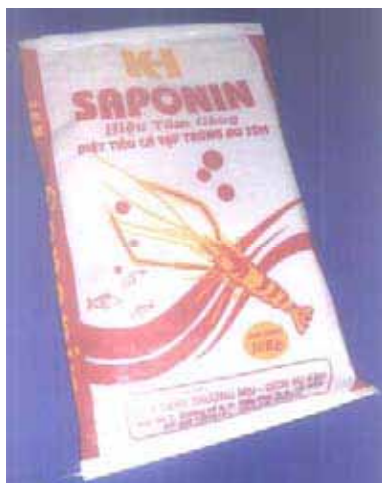

1.1



1.2

- (11) **13096**
(21) 3-2008-00537 (28) 01
(54) GHẾ (51) **06-01**
(22) 17.04.2008 (43) 25.06.2008
(71) CÔNG TY CỔ PHẦN CAO SU SÀI GÒN - KYMDAN (VN)
28 Bình Thới, phường 14, quận 11, TP. Hồ Chí Minh
(72) Nguyễn Hữu Trí (VN)
(74) Công ty TNHH Sở hữu trí tuệ Thảo Thọ Quyến (INVENCO)
(55)



1.1



1.2



1.3



1.4



1.5

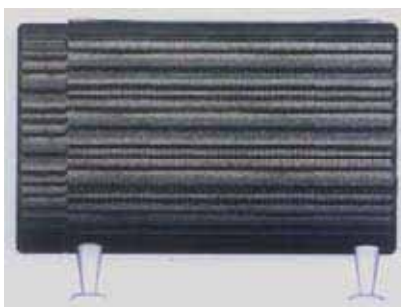

1.6

- (11) **13097**
(21) 3-2008-00538 (28) 01
(54) GHẾ (51) **06-01**
(22) 17.04.2008 (43) 25.06.2008
(71) CÔNG TY CỔ PHẦN CAO SU SÀI GÒN - KYMDAN (VN)
28 Bình Thới, phường 14, quận 11, TP. Hồ Chí Minh
(72) Nguyễn Hữu Trí (VN)
(74) Công ty TNHH Sở hữu trí tuệ Thảo Thọ Quyến (INVENCO)
(55)



1.1

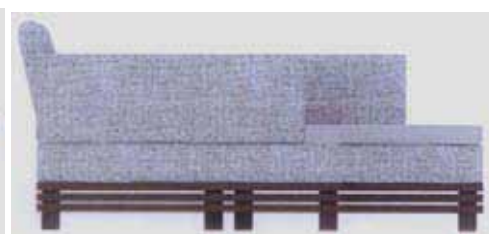

1.2



1.3

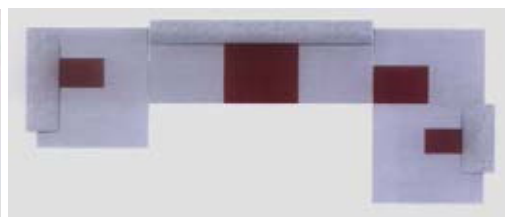

1.4



1.5



1.6

- (11) **13098**
(21) 3-2008-00544 (28) 01
(54) ĐĨA (51) **07-01**
(22) 17.04.2008 (43) 25.06.2008
(71) SRITHAI SUPERWARE PUBLIC COMPANY LIMITED (TH)
355 Suksawat Rd., Soi 36 Rasburana Bangkok 10140, Thailand
(72) SUPAP KITIPOON (TH)
(74) Công ty Cổ phần Sở hữu công nghiệp INVESTIP (INVESTIP)
(55)



1.1

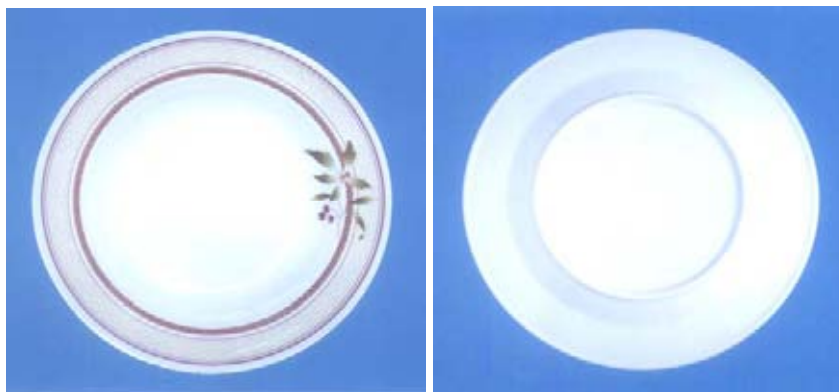

1.2

1.3



1.4

- (11) **13099**
(21) 3-2008-00545
(54) CHAI
(22) 17.04.2008
(71) CÔNG TY TNHH CHẾ BIẾN NƯỚC CHẤM MEKONG (VN)
Tỉnh lộ 10, xã Đức Hòa Hạ, huyện Đức Hoà, tỉnh Long An
(72) Phan Bảo Duy (VN)
(74) Văn phòng luật sư Phạm và Liên danh (PHAM & ASSOCIATES)
(55)
- (28) 01
(51) **09-01**
(43) 25.06.2008

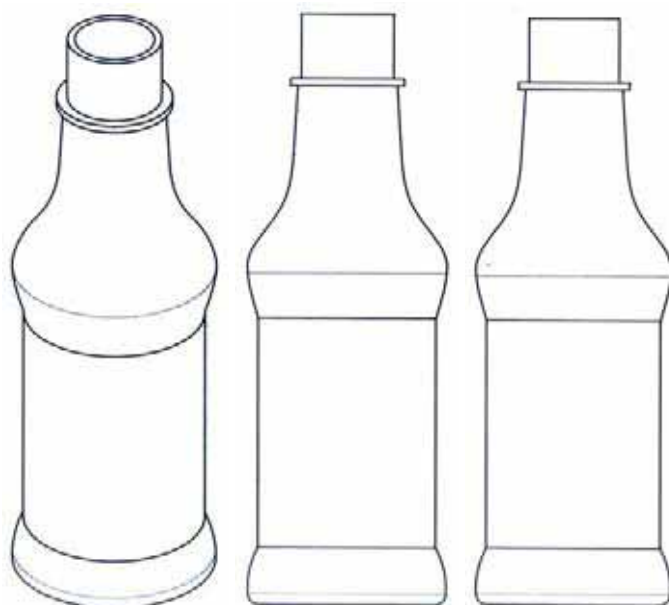

1.1

1.2

1.3

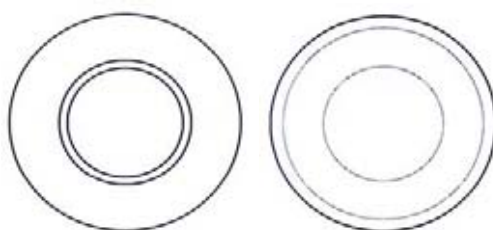

1.4

1.5

- (11) **13100**
(21) 3-2008-00546
(54) CHAI
(22) 17.04.2008
(71) CÔNG TY TNHH CHẾ BIẾN NƯỚC CHẤM MEKONG (VN)
Tỉnh lộ 10, xã Đức Hòa Hạ, huyện Đức Hoà, tỉnh Long An
(72) Phan Bảo Duy (VN)
(74) Văn phòng luật sư Phạm và Liên danh (PHAM & ASSOCIATES)
(55)
- (28) 01
(51) **09-01**
(43) 25.06.2008

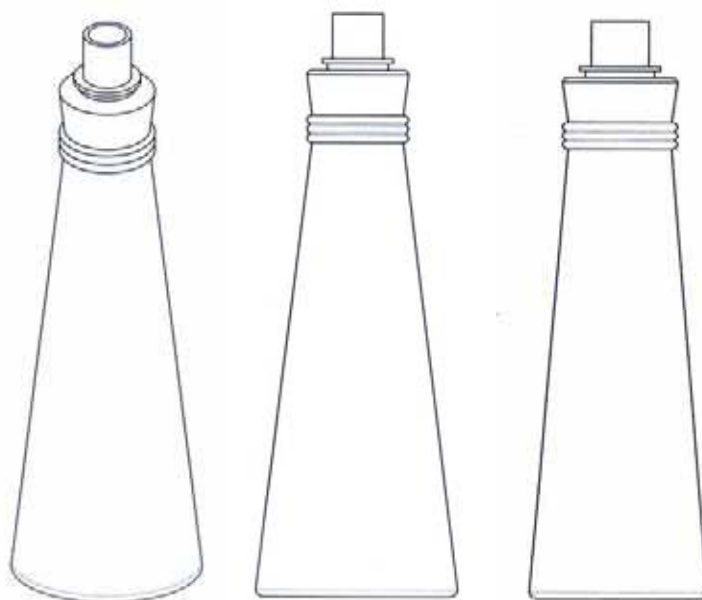

1.1

1.2

1.3

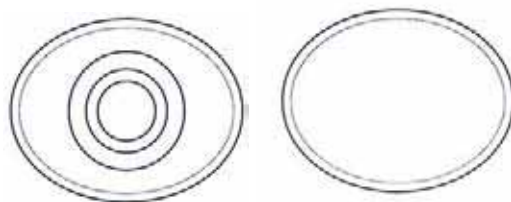

1.4

1.5

- (11) **13101**
(21) 3-2008-00551 (28) 01
(54) NHÃN SẢN PHẨM (51) **19-08**
(22) 21.04.2008 (43) 25.06.2008
(71) CÔNG TY TRÁCH NHIỆM HỮU HẠN THƯƠNG MẠI VÀ DỊCH VỤ K & H (VN)
Lô 5 đường Nước Lên, khu công nghiệp Tân Tạo, quận Bình Tân, TP. Hồ Chí Minh
(72) Nguyễn Thiên Hương (VN)
(74) Công ty TNHH Sở hữu trí tuệ Thảo Thọ Quyến (INVENCO)
(55)



1.1

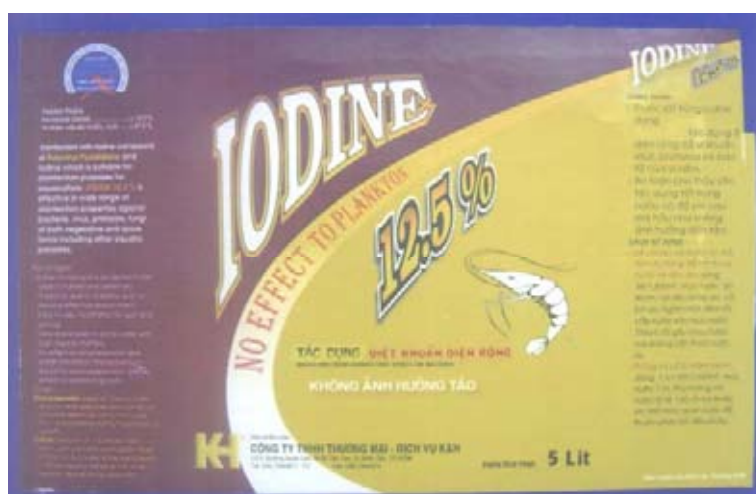

1.2

- (11) **13102**
(21) 3-2008-00553 (28) 01
(54) BAO GÓI THUỐC (51) **09-05**
(22) 21.04.2008 (43) 25.06.2008
(71) CÔNG TY CỔ PHẦN DƯỢC TW MEDIPLANTEX (VN)
358 đường Giải Phóng, phường Phương Liệt, quận Thanh Xuân, thành phố Hà Nội
(72) Trần Bình Duyên (VN)
(74) Công ty TNHH Sở hữu trí tuệ PADEMARK (PADEMARK CO.,LTD.)
(55)



1.1



1.2

- (11) **13103**
(21) 3-2008-00554 (28) 02
(54) **ĐĨA** (51) **07-01**
(22) 21.04.2008 (43) 25.06.2008
(71) **SRITHAI SUPERWARE PUBLIC COMPANY LIMITED (TH)**
355 Suksawat Rd., Soi 36 Rasburana Bangkok 10140, Thailand
(72) Udon Wansean (TH)
(74) Công ty Cổ phần Sở hữu công nghiệp INVESTIP (INVESTIP)
(55)



1.1

1.2

1.3



1.4

1.5

1.6



1.7

1.8

- (11) **13104**
(21) 3-2008-00555 (28) 01
(54) ĐĨA (51) **07-01**
(22) 21.04.2008 (43) 25.06.2008
(71) SRITHAI SUPERWARE PUBLIC COMPANY LIMITED (TH)
355 Suksawat Rd., Soi 36 Rasburana Bangkok 10140, Thailand
(72) UDON WANSEAN (TH)
(74) Công ty Cổ phần Sở hữu công nghiệp INVESTIP (INVESTIP)
(55)



1.1



1.2

1.3



1.4

- (11) **13105**
(21) 3-2008-00556 (28) 01
(54) ĐĨA (51) **07-01**
(22) 21.04.2008 (43) 25.06.2008
(71) SRITHAI SUPERWARE PUBLIC COMPANY LIMITED (TH)
355 Suksawat Rd., Soi 36 Rasburana Bangkok 10140, Thailand
(72) SOMCHAI NUNPUN (TH)
(74) Công ty Cổ phần Sở hữu công nghiệp INVESTIP (INVESTIP)
(55)



1.1

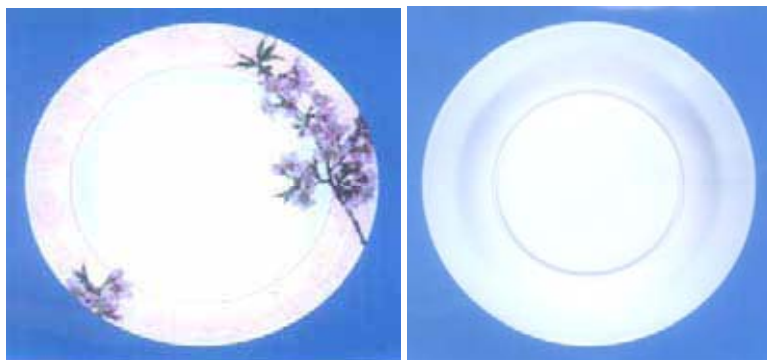

1.2

1.3



1.4

- (11) **13106**
(21) 3-2008-00557 (28) 01
(54) ĐÈN BÀN (51) **26-05**
(22) 21.04.2008 (43) 25.06.2008
(71) CÔNG TY TNHH SẢN XUẤT - THƯƠNG MẠI - DỊCH VỤ - XUẤT NHẬP KHẨU
TUẤN BẢO (VN)
8-10-12-14 lô A đường số 3, phường 11, quận 6, TP. Hồ Chí Minh
(72) Trần Anh Tuấn (VN)
(74) DNTN Dịch vụ thương mại và sở hữu công nghiệp Song Ngọc (I.P.T.S.)
(55)



1.1



1.2



1.3



1.4



1.5



1.6



1.7

- (11) **13107**
(21) 3-2008-00558 (28) 01
(54) VÒI NƯỚC (51) **23-01**
(22) 22.04.2008 (43) 25.06.2008
(71) CÔNG TY TNHH KỸ THUẬT NƯỚC VI NA (VN)
63/18/24 Chu Thiên, phường Hiệp Tân, quận Tân Phú, TP. Hồ Chí Minh
(72) Lương Thị Phượng (VN)
(55)

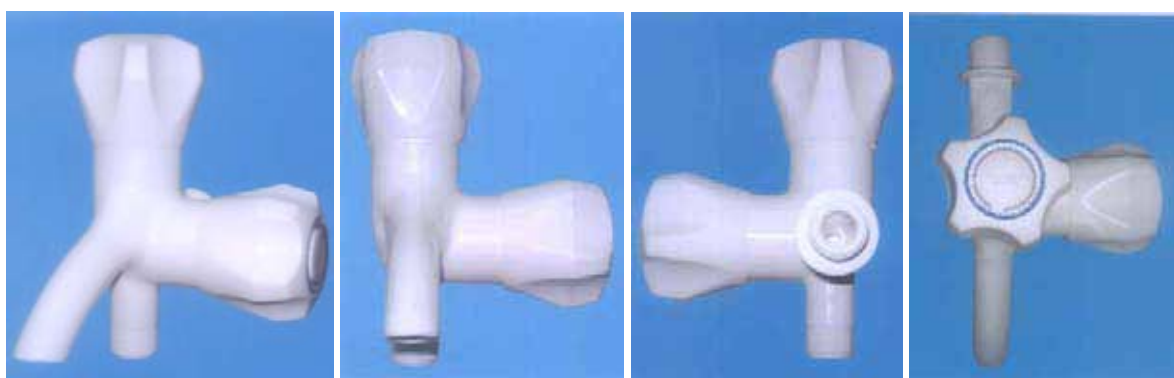

1.1

1.2

1.3

1.4

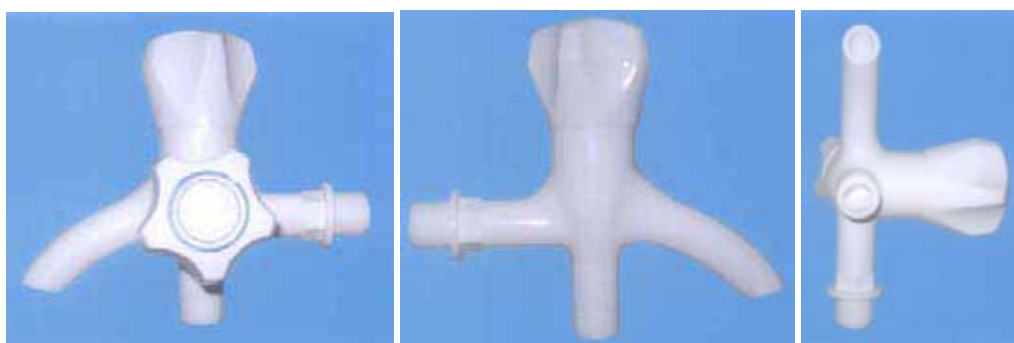

1.5

1.6

1.7

- (11) **13108**
(21) 3-2008-00564 (28) 01
(54) ĐĨA (51) **07-01**
(22) 22.04.2008 (43) 25.06.2008
(71) SRITHAI SUPERWARE PUBLIC COMPANY LIMITED (TH)
355 Suksawat Rd., Soi 36 Rasburana Bangkok 10140, Thailand
(72) SUPAP KITIPOON (TH)
(74) Công ty Cổ phần Sở hữu công nghiệp INVESTIP (INVESTIP)
(55)



1.1



1.2

1.3



1.4

- (11) **13109**
(21) 3-2008-00565 (28) 01
(54) ĐĨA (51) **07-01**
(22) 22.04.2008 (43) 25.06.2008
(71) SRITHAI SUPERWARE PUBLIC COMPANY LIMITED (TH)
355 Suksawat Rd., Soi 36 Rasburana Bangkok 10140, Thailand
(72) UDON WANSEAN (TH)
(74) Công ty Cổ phần Sở hữu công nghiệp INVESTIP (INVESTIP)
(55)



1.1



1.2

1.3

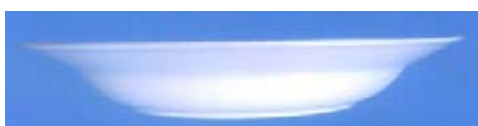

1.4

- (11) **13110**
(21) 3-2008-00572 (28) 01
(54) VÒI NƯỚC (51) **23-01**
(22) 23.04.2008 (43) 25.06.2008
(71) WATERTEC (MALAYSIA) SDN BHD (MY)
Lot 6 Jalan Halba 16/16, Section 16, 40200 Shah Alam, Selangor, Malaysia
(72) Mohd Nizam Bin Najmuddin (MY)
(74) Công ty TNHH Tư vấn Phạm Anh Nguyên (ANPHAMCO CO.,LTD.)
(55)



1.1



1.2

1.3

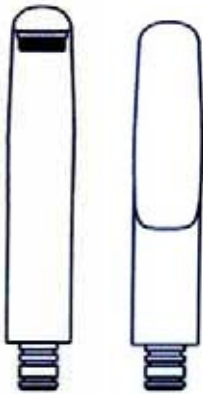

1.4



1.5



1.6

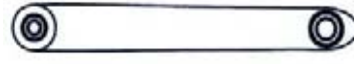

1.7

- (11) **13111**
(21) 3-2008-00573 (28) 01
(54) **VÒI NƯỚC** (51) **23-01**
(22) 23.04.2008 (43) 25.06.2008
(71) WATERTEC (MALAYSIA) SDN BHD (MY)
Lot 6 Jalan Halba 16/16, Section 16, 40200 Shah Alam, Selangor, Malaysia
(72) Mohd Nizam Bin Najmuddin (MY)
(74) Công ty TNHH Tư vấn Phạm Anh Nguyên (ANPHAMCO CO.,LTD.)
(55)



1.1

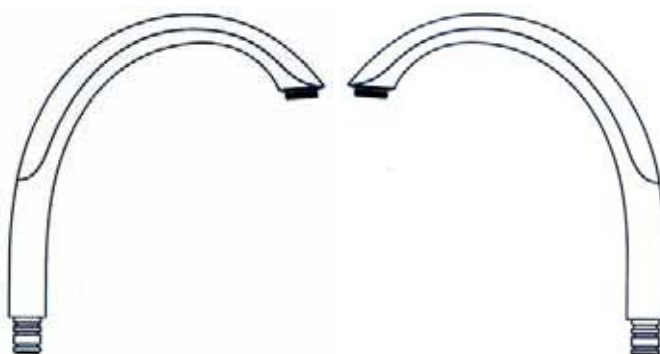

1.2

1.3



1.4



1.5

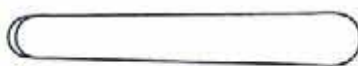

1.6



1.7

- (11) **13112**
(21) 3-2008-00577 (28) 01
(54) **ĐĨA** (51) **07-01**
(22) 23.04.2008 (43) 25.06.2008
(71) SRITHAI SUPERWARE PUBLIC COMPANY LIMITED (TH)
355 Suksawat Rd., Soi 36 Rasburana Bangkok 10140, Thailand
(72) UDON WANSEAN (TH)
(74) Công ty Cổ phần Sở hữu công nghiệp INVESTIP (INVESTIP)
(55)

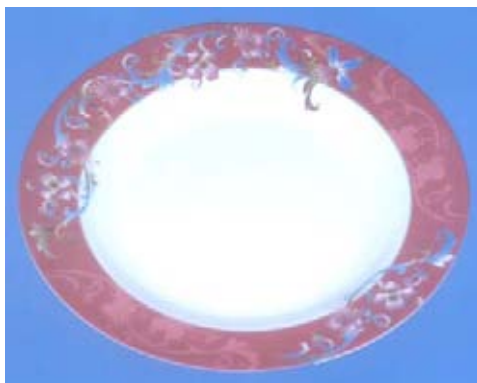

1.2



1.2

1.3



1.4

- (11) **13113**
(21) 3-2008-00581 (28) 01
(54) TỦ NHỰA (51) **06-04**
(22) 25.04.2008 (43) 25.06.2008
(71) CÔNG TY CỔ PHẦN ĐẠI ĐỒNG TIẾN (VN)
216 Tân Thành, phường 15, quận 5, TP. Hồ Chí Minh
(72) Trịnh Đồng (VN)
(74) DNTN Dịch vụ thương mại và sở hữu công nghiệp Song Ngọc (I.P.T.S.)
(55)

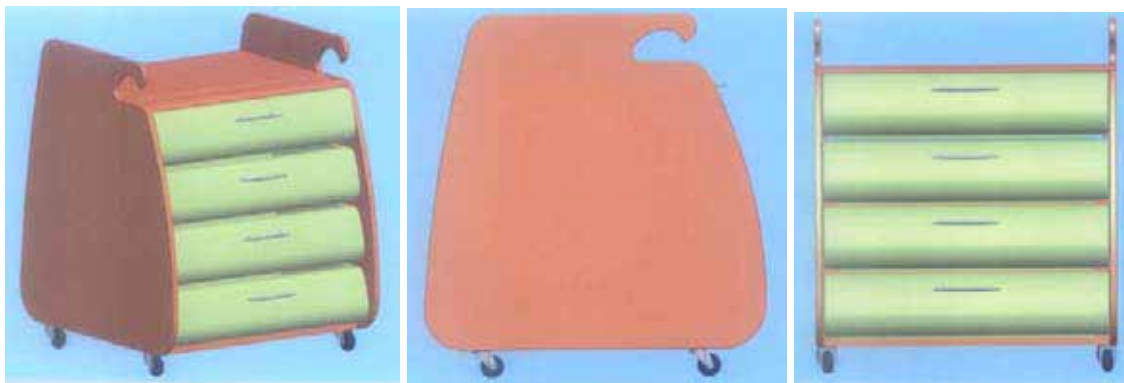

1.1

1.2

1.3

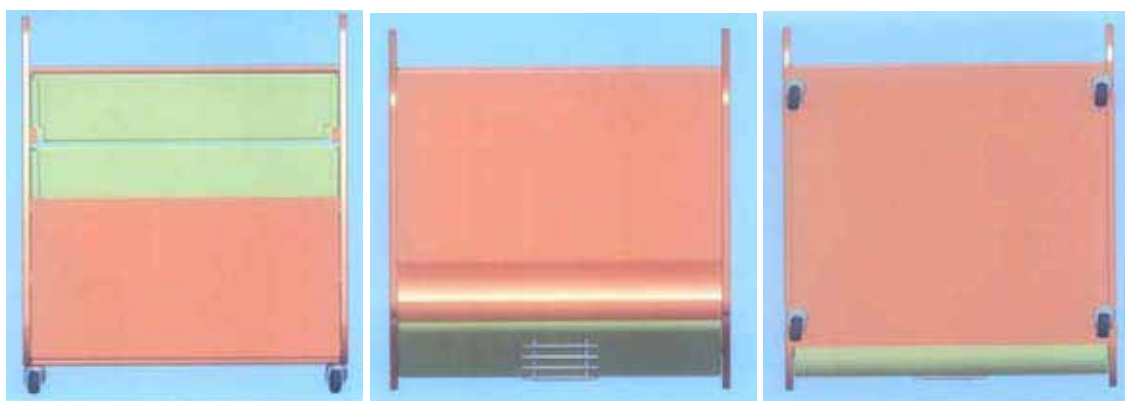

1.4

1.5

1.6

- (11) **13114**
(21) 3-2008-00582 (28) 01
(54) GHẾ NHỰA (51) **06-01**
(22) 25.04.2008 (43) 25.06.2008
(71) CÔNG TY CỔ PHẦN ĐẠI ĐỒNG TIẾN (VN)
216 Tân Thành, phường 15, quận 5, TP. Hồ Chí Minh
(72) Trịnh Đồng (VN)
(74) DNTN Dịch vụ thương mại và sở hữu công nghiệp Song Ngọc (I.P.T.S.)
(55)

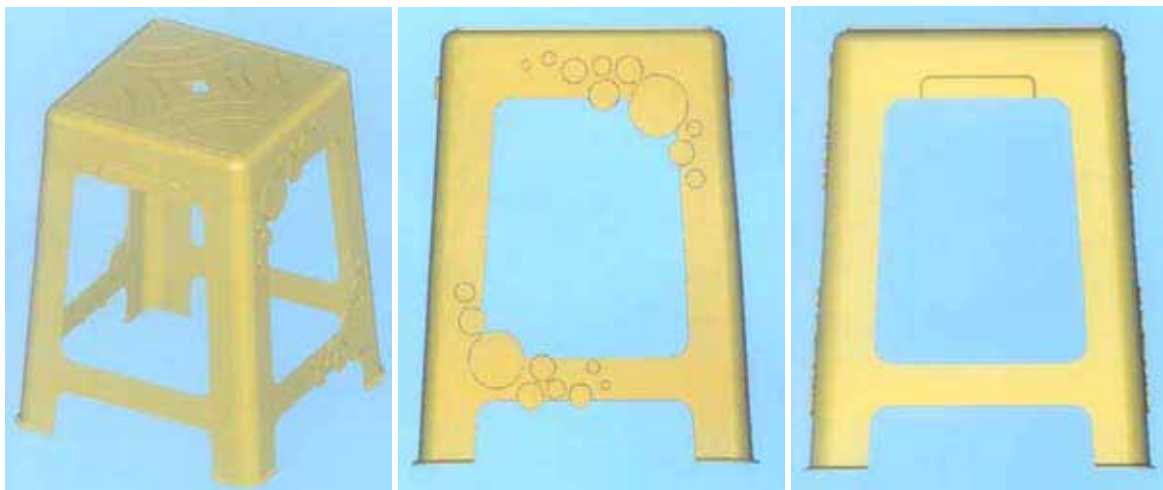

1.1

1.2

1.3

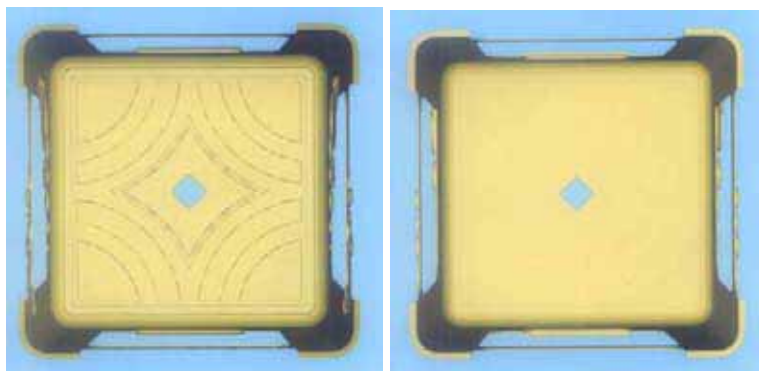

1.4

1.5

- (11) **13115**
(21) 3-2008-00596 (28) 01
(54) **VẬT DỤNG KHỬ MÙI KHÔNG KHÍ** (51) **28-99**
(22) 29.04.2008 (43) 25.06.2008
(30) 000868336-0001 29.01.2008 EM
(71) SARA LEE HOUSEHOLD AND BODY CARE NEDERLAND B.V. (NL)
Vleutensevaart 35, 3532 AD Utrecht, The Netherlands
(72) Bjorn Weggelaar (NL)
(74) Công ty TNHH một thành viên Sở hữu trí tuệ VCCI (VCCI-IP CO.,LTD)
(55)



1.1

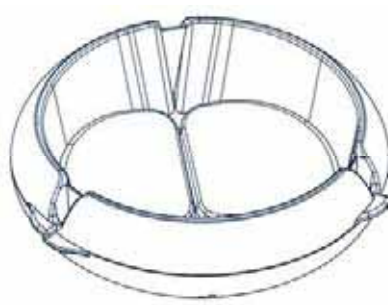

1.2



1.3



1.4

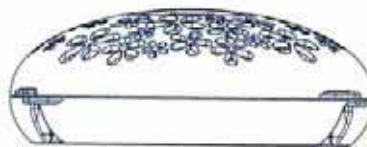

1.5



1.6



1.7



1.8

- (11) **13116**
(21) 3-2008-00601 (28) 01
(54) XE ĐẨY TAY (51) **12-02**
(22) 02.05.2008 (43) 25.06.2008
(71) PHƯƠNG THỊ HỢP (VN)
152 Hà Tôn Quyền, phường 4, quận Tân Bình, TP. Hồ Chí Minh
(72) Phương Thị Hợp (VN)
(74) DNTN Dịch vụ thương mại và sở hữu công nghiệp Song Ngọc (I.P.T.S.)
(55)



1.1



1.2



1.3



1.4



1.5



1.6

- (11) **13117**
(21) 3-2008-00603 (28) 01
(54) XE MÔ TÔ (51) **12-11**
(22) 05.05.2008 (43) 25.06.2008
(71) SANYANG INDUSTRY CO., LTD. (TW)
No. 184, Keng Tzu Kou, Shang Keng Village, Hsin Fong Shiang, Hsinchu, County 304,
Taiwan
(72) Chao-Fu CHOU (TW)
(74) Công ty TNHH Trường Xuân (AGELESS CO.,LTD.)
(55)



1.1



1.2



1.3



1.4



1.5



1.6



1.7



1.8



1.9