

PHẦN III

**ĐƠN YÊU CẦU CẤP BẰNG ĐỘC QUYỀN KIỂU DÁNG CÔNG NGHIỆP**

- |      |   |      |              |
|------|---|------|--------------|
| (11) | <b>13225</b>  |      |              |
| (21) | 3-2007-01688  | (28) | 02           |
| (54) | BỘ QUÂN ÁO THỂ THAO   | (51) | <b>02-02</b> |
| (22) | 04.12.2007  | (43) | 25.08.2008   |
| (71) | CÔNG TY CỔ PHẦN ĐỘNG LỰC (VN)<br>130 Hạ Đình, quận Thanh Xuân, thành phố Hà Nội |      |              |
| (72) | Trần Đình Trung (VN)  |      |              |
| (55) |   |      |              |

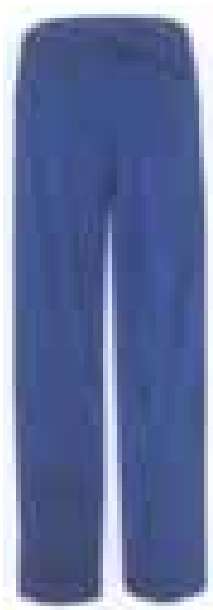



- (11) **13226**  
(21) 3-2007-01896 (28) 01  
(54) BÌNH LỌC NƯỚC (51) **23-01**  
(22) 31.12.2007 (43) 25.08.2008  
(71) CÔNG TY TNHH CÔNG NGHỆ HCTH (VN)  
Km2, đường 196 xã Nhân Hoà, huyện Mỹ Hào, tỉnh Hưng Yên  
(72) TADAS JURGUTIS (LT)  
(74) Công ty cổ phần Tư vấn đầu tư quốc tế G4 Việt Nam (G4 VIETNAM. CORP.)  
(55)

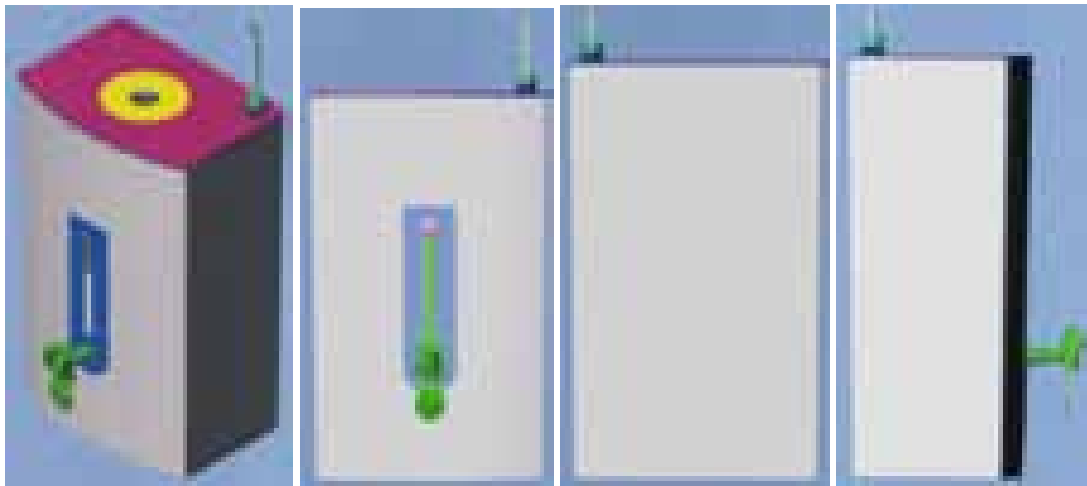

1.1

1.2

1.3

1.4

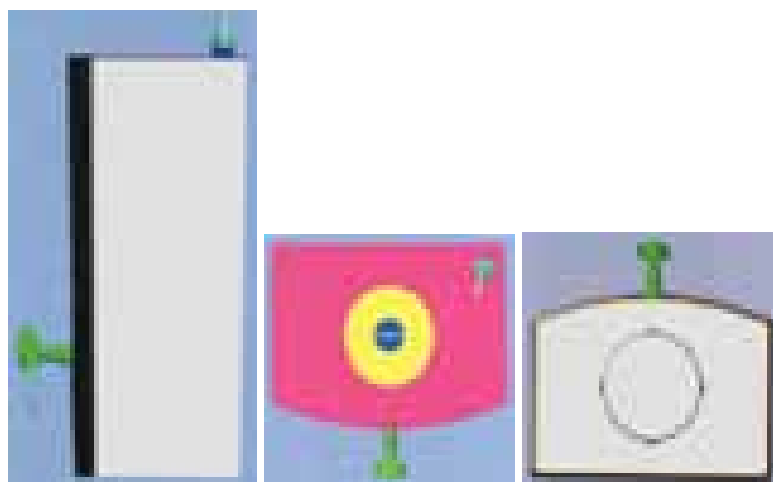

1.5

1.6

1.7

- (11) **13227**  
(21) 3-2007-01897 (28) 01  
(54) BÌNH (51) **10-05**  
(22) 31.12.2007 (43) 25.08.2008  
(71) CÔNG TY TNHH CÔNG NGHỆ HCTH (VN)  
Km2, đường 196 xã Nhân Hoà, huyện Mỹ Hào, tỉnh Hưng Yên  
(72) TADAS JURGUTIS (LT)  
(74) Công ty cổ phần Tư vấn đầu tư quốc tế G4 Việt Nam (G4 VIETNAM. CORP.)  
(55)

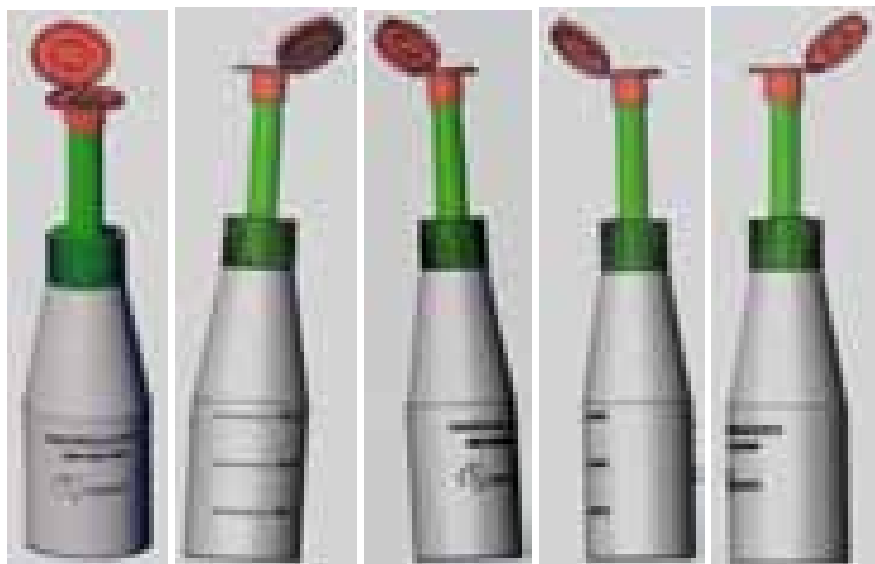

1.1

1.2

1.3

1.4

1.5



1.6

1.7

- (11) **13228**  
(21) 3-2008-00185 (28) 01  
(54) CÔNG TẮC ĐIỆN (51) **13-03**  
(22) 30.01.2008 (43) 25.08.2008  
(30) 316504 30.07.2007 AU  
(71) CLIPSAL AUSTRALIA PTY LTD. (AU)  
12 Park Terrace Bowden 5007, South Australia, Australia  
(72) Eddy Rinna (AU)  
(74) Công ty TNHH một thành viên Sở hữu trí tuệ VCCI (VCCI-IP CO.,LTD)  
(55)

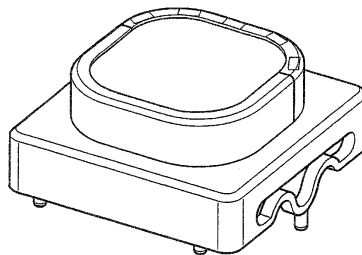

1.1

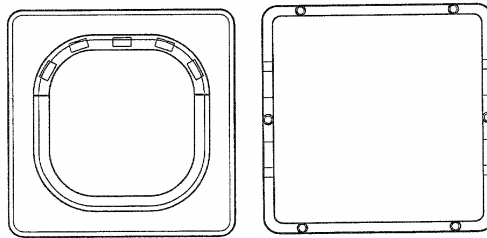

1.2

1.3

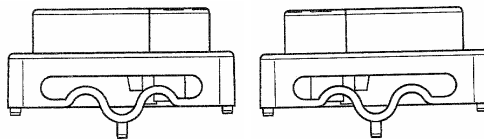

1.4

1.5

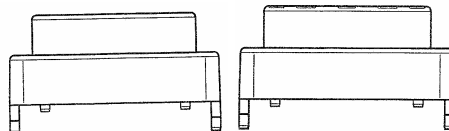

1.6

1.7

- (11) **13229**  
(21) 3-2008-00186 (28) 01  
(54) CÔNG TẮC ĐIỆN (51) **13-03**  
(22) 30.01.2008 (43) 25.08.2008  
(30) 316505 30.07.2007 AU  
(71) CLIPSAL AUSTRALIA PTY LTD. (AU)  
12 Park Terrace Bowden 5007, South Australia, Australia  
(72) Eddy Rinna (AU), Alvin Lam (AU)  
(74) Công ty TNHH một thành viên Sở hữu trí tuệ VCCI (VCCI-IP CO.,LTD)  
(55)

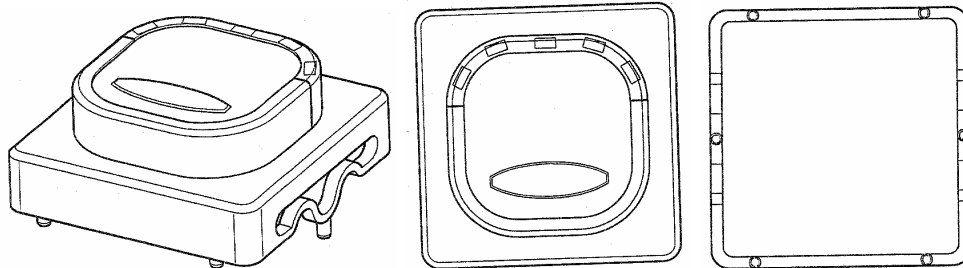

1.1

1.2

1.3

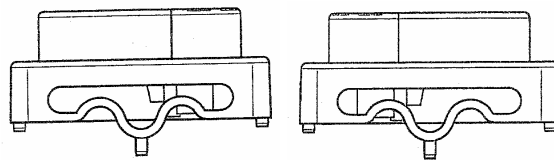

1.4

1.5

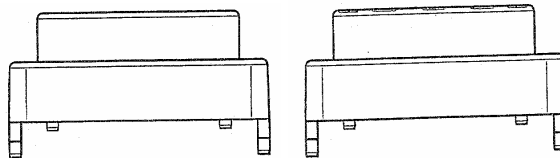

1.6

1.7

- (11) **13230**  
(21) 3-2008-00199 (28) 02  
(54) HỘP ĐUNG MỰC IN (51) **18-02**  
(22) 29.03.2006 (43) 25.08.2008  
(30) 2006-004995 28.02.2006 JP  
2006-004996 28.02.2006 JP  
(71) BROTHER INDUSTRIES, LTD. (JP)  
15-1 Naeshiro-cho, Mizuho-ku, Nagoya-shi, Aichi-ken, Japan  
(72) Shingo Hattori (JP)  
(74) Công ty TNHH Ban Ca (BANCA)  
(55)

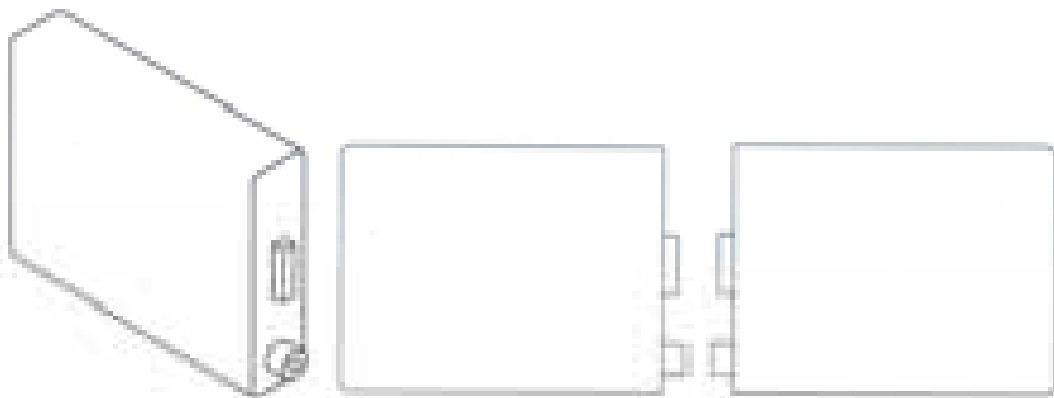

1.1

1.2

1.3



1.4

1.5

1.6

1.7



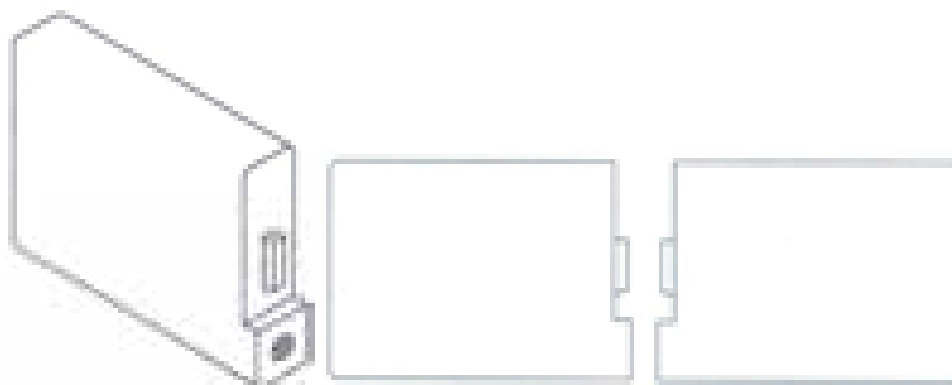

2.1

2.2

2.3



2.4

2.5

2.6

2.7

- (11) **13231**  
(21) 3-2008-00200 (28) 02  
(54) HỘP ĐUNG MỰC IN (51) **18-02**  
(22) 29.03.2006 (43) 25.08.2008  
(30) 2006-004992 28.02.2006 JP  
2006-004993 28.02.2006 JP  
(71) BROTHER INDUSTRIES, LTD. (JP)  
15-1 Naeshiro-cho, Mizuho-ku, Nagoya-shi, Aichi-ken, Japan  
(72) Shingo Hattori (JP)  
(74) Công ty TNHH Ban Ca (BANCA)  
(55)



1.1

1.2

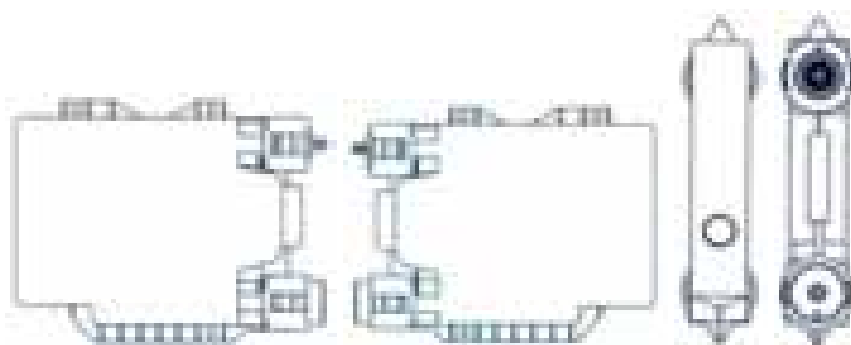

1.3

1.4

1.5

1.6



1.7

1.8

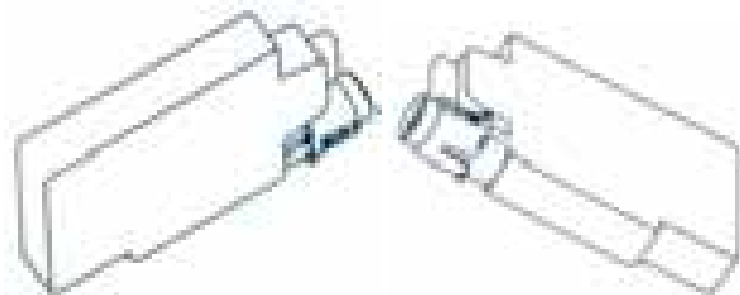

2.1

2.2



2.3

2.4

2.5

2.6



2.7

2.8

- (11) **13232**  
(21) 3-2008-00201 (28) 01  
(54) HỘP ĐUNG MỰC IN (51) **18-02**  
(22) 29.03.2006 (43) 25.08.2008  
(30) 2006-004994 28.02.2006 JP  
(71) BROTHER INDUSTRIES, LTD. (JP)  
15-1 Naeshiro-cho, Mizuho-ku, Nagoya-shi, Aichi-ken, Japan  
(72) Shingo Hattori (JP)  
(74) Công ty TNHH Ban Ca (BANCA)  
(55)

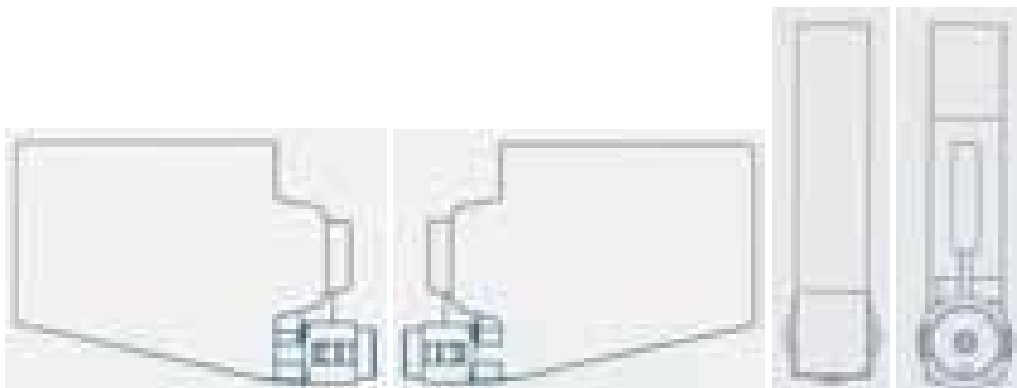
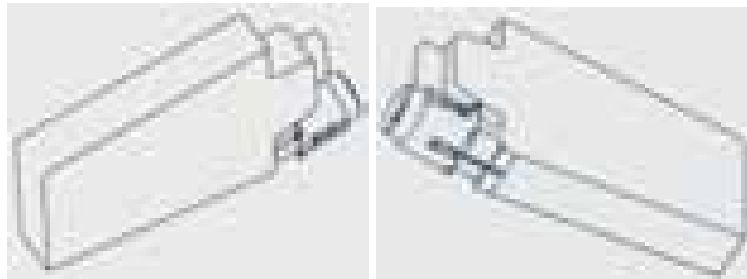

- (11) **13233**  
(21) 3-2008-00290 (28) 01  
(54) DÉP (51) **02-04**  
(22) 26.02.2008 (43) 25.08.2008  
(71) DOANH NGHIỆP TƯ NHÂN GIÀY Á CHÂU (VN)  
567/K 35 J Nguyễn Tri Phương, phường 14, quận 10, TP. Hồ Chí Minh  
(72) Nguyễn Đình Kim (VN)  
(74) Công ty TNHH A.M.B.Y.S (AMBYS CO.LTD.)  
(55)



1.1



1.2



1.3



1.4



1.5



1.6

- (11) **13234**  
(21) 3-2008-00294 (28) 01  
(54) DỤNG CỤ NHA KHOA (51) **24-02**  
(22) 27.02.2008 (43) 25.08.2008  
(30) 19535/2007 28.08.2007 AU  
(71) CHRISTOPHER JOHN FARRELL (AU)  
Suite 27-28, Helensvale Plaza, Sir John Overall Drive, Helensvale Queensland 4212,  
Australia  
(72) Christopher John Farrell (US)  
(74) Công ty TNHH Trần Hữu Nam và Đồng sự (TRAN H.N & ASS.)  
(55)



1.1

1.2

1.3



1.4

1.5

1.6

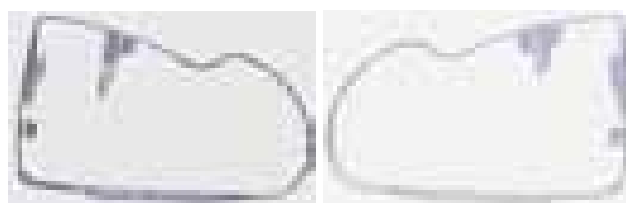

1.7

1.8

- (11) **13235**  
(21) 3-2008-00304 (28) 02  
(54) GHẾ (51) **06-05**  
(22) 28.02.2008 (43) 25.08.2008  
(30) 000779830 28.08.2007 EM  
(71) WONDERLAND NURSERYGOODS CO., LTD. (VG)  
Offshore Incorporations Centre, Road Town, Tortola, British Virgin Islands  
(72) Imre Peter Jacobs (NL), Martijn Hans Van Gelderen (NL), Eric Biermann (NL), Fiona  
Amy Van Petegem (NL)  
(74) Văn phòng luật sư Phạm và Liên danh (PHAM & ASSOCIATES)  
(55)



1.1

1.2

1.3

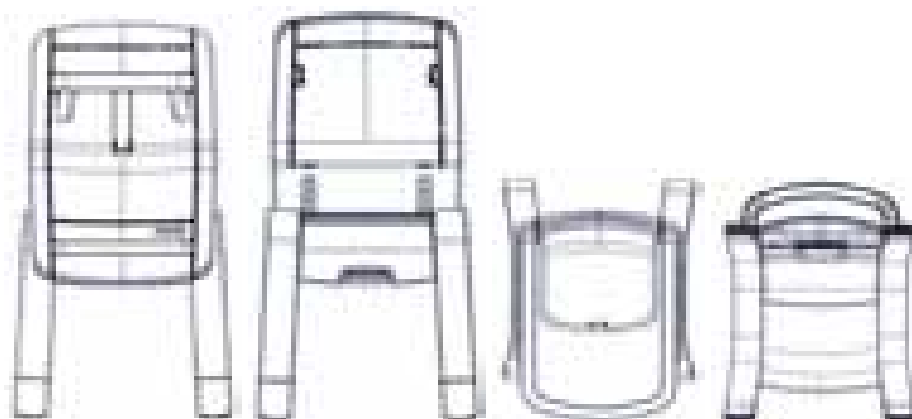

1.4

1.5

1.6

1.7



2.1

2.2

2.3

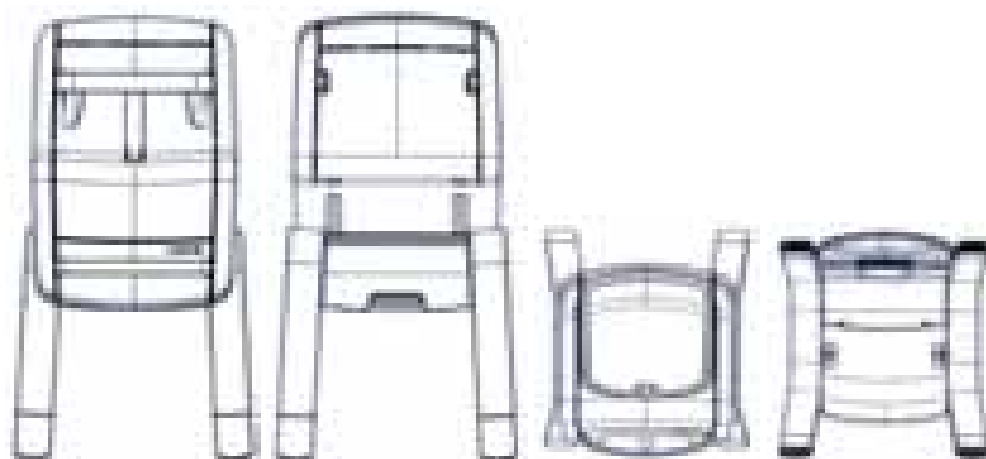

2.4

2.5

2.6

2.7



- (11) **13236**  
(21) 3-2008-00305 (28) 01  
(54) BỘ KHOÁ CÀI (51) **02-07**  
(22) 28.02.2008 (43) 25.08.2008  
(30) 000779848 28.08.2007 EM  
(71) WONDERLAND NURSERYGOODS CO., LTD. (VG)  
Offshore Incorporations Centre, Road Town, Tortola, British Virgin Islands  
(72) Imre Peter Jacobs (NL), Martijn Hans Van Gelderen (NL), Eric Biermann (NL), Fiona  
Amy Van Petegem (NL)  
(74) Văn phòng luật sư Phạm và Liên danh (PHAM & ASSOCIATES)  
(55)

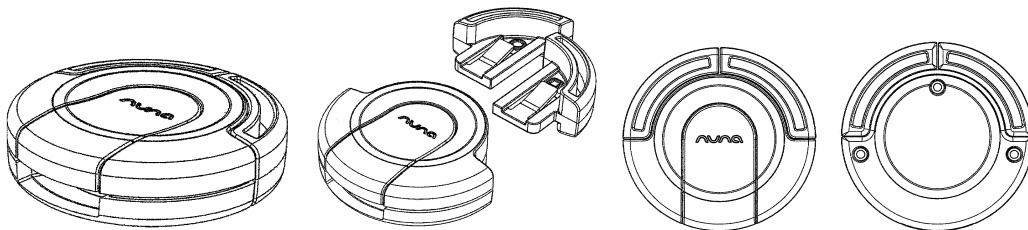

1.1

1.2

1.3

1.4

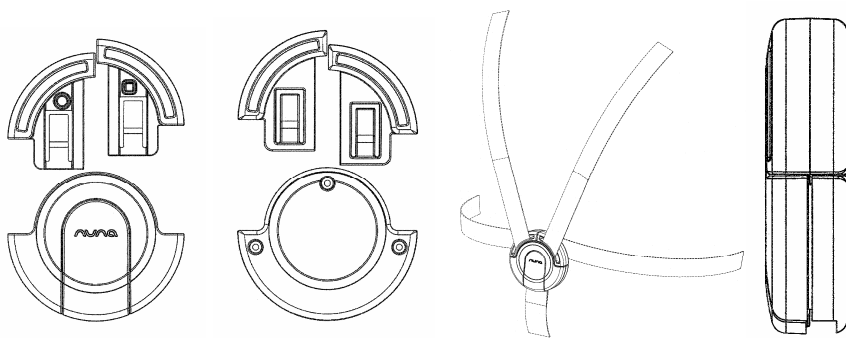

1.5

1.6

1.7

1.8

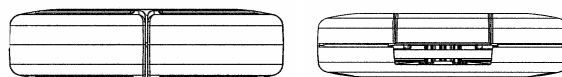

1.9

1.10

- (11) **13237**  
(21) 3-2008-00344 (28) 01  
(54) DỤNG CỤ XÓA PHỦ (51) **19-02**  
(22) 11.03.2008 (43) 25.08.2008  
(30) 2007-025218 18.09.2007 JP  
(71) KOKUYO CO., LTD. (JP)  
1-1, Oimazato-minami 6-chome, Higashinari-ku, Osaka-shi, Osaka, Japan  
(72) Kinya MATSUSHITA (JP), Hideto SHIMA (JP)  
(74) Công ty TNHH Sở hữu trí tuệ Thảo Thọ Quyển (INVENCO)  
(55)



1.1

1.2

1.3



1.4

1.5

1.6



1.7

1.8

1.9



1.10

1.11

1.12

1.13

- (11) **13238**  
 (21) 3-2008-00345 (28) 01  
 (54) DỤNG CỤ XÓA PHỦ (51) **19-02**  
 (22) 11.03.2008 (43) 25.08.2008  
 (30) 2007-025216 18.09.2007 JP  
 (71) KOKUYO CO., LTD. (JP)  
 1-1, Oimazato-minami 6-chome, Higashinari-ku, Osaka-shi, Osaka, Japan  
 (72) Kinya MATSUSHITA (JP), Hideto SHIMA (JP)  
 (74) Công ty TNHH Sở hữu trí tuệ Thảo Thọ Quyển (INVENCO)  
 (55)



1.1

1.2

1.3



1.4

1.5

1.6



1.7

1.8

1.9

1.10

1.11



1.12

1.13

1.14

1.15

- (11) **13239**  
(21) 3-2008-00398 (28) 01  
(54) CHAI (51) **09-01**  
(22) 24.03.2008 (43) 25.08.2008  
(71) CÔNG TY CỔ PHẦN NƯỚC KHOÁNG VĨNH HẢO (VN)  
Số 72, đường 19/4, phường Xuân An, thành phố Phan Thiết, tỉnh Bình Thuận  
(72) Nguyễn Hữu Dũng (VN)  
(55)



1.1

1.2

1.3

1.4

1.5



1.6

1.7

- (11) **13240**  
(21) 3-2008-00424 (28) 01  
(54) HỘP ĐỰNG HAI CHAI RƯỢU BỔ (51) **09-03**  
SÂM QUY  
(22) 27.03.2008 (43) 25.08.2008  
(71) CÔNG TY CỔ PHẦN DƯỢC - VẬT TƯ Y TẾ THÁI BÌNH (VN)  
30A Hai Bà Trưng, phường Lê Hồng Phong, thành phố Thái Bình, tỉnh Thái Bình  
(72) Nguyễn Văn Đường (VN)  
(74) Trung tâm Tư vấn đầu tư và Công nghệ (VIETBID)  
(55)



1.1



1.2

- (11) **13241**  
(21) 3-2008-00432 (28) 02  
(54) VÒI NƯỚC (51) **23-01**  
(22) 27.03.2008 (43) 25.08.2008  
(71) CÔNG TY TNHH KỸ THUẬT NƯỚC VI NA (VN)  
63/18/24 Chu Thiên, phường Hiệp Tân, quận Tân Phú, TP. Hồ Chí Minh  
(72) Lương Thị Phượng (VN)  
(55)



1.1

1.2

1.3

1.4

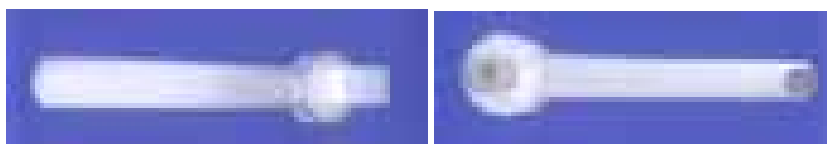

1.5

1.6



2.1

2.2



2.3

2.4

2.5

2.6

- (11) **13242**  
(21) 3-2008-00441 (28) 02  
(54) NHÃN SẢN PHẨM (51) **19-08**  
(22) 28.03.2008 (43) 25.08.2008  
(71) CÔNG TY CỔ PHẦN NƯỚC MẮM PHAN THIẾT (VN)  
Đường Nguyễn Thông, phường Phú Hải, thành phố Phan Thiết  
(72) Lê Trần Phú Đức (VN)  
(74) Văn phòng luật sư Phạm và Liên danh (PHAM & ASSOCIATES)  
(55)



1.1



1.2





2.1

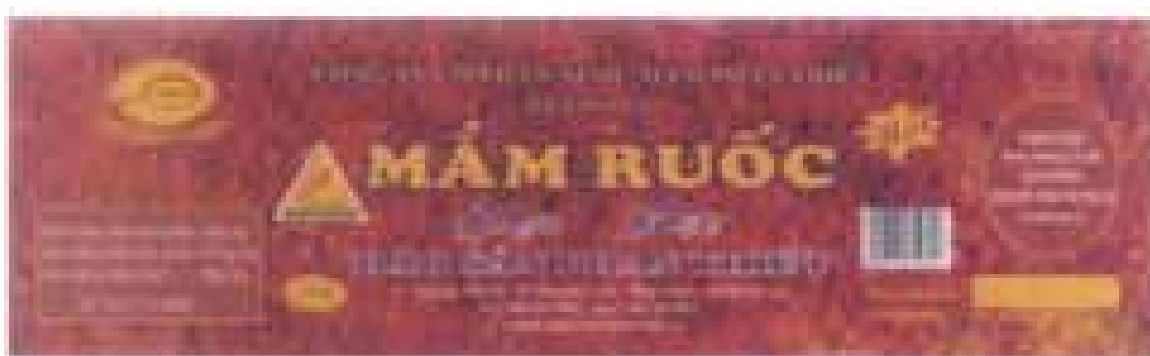

2.2

- (11) **13243**  
(21) 3-2008-00451 (28) 01  
(54) Ô TÔ (51) **12-08**  
(22) 31.03.2008 (43) 25.08.2008  
(30) 2007-031120 09.11.2007 JP  
(71) NISSAN JIDOSHA KABUSHIKI KAISHA (NISSAN MOTOR CO., LTD.) (JP)  
No. 2, Takaracho, Kanagawa-ku, Yokohama-shi, Kanagawa-ken, Japan  
(72) KAZUNORI MURABAYASHI (JP)  
(74) Công ty TNHH Sở hữu trí tuệ Thảo Thọ Quyển (INVENCO)  
(55)



1.1



1.2

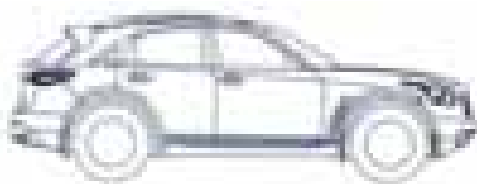

1.3

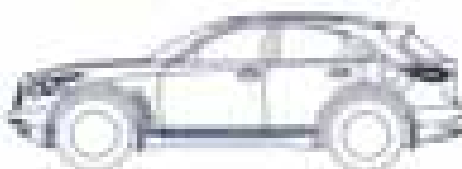

1.4



1.5



1.6



1.7



1.8

- (11) **13244**  
(21) 3-2008-00458 (28) 01  
(54) NHÃN SẢN PHẨM (51) **19-08**  
(22) 31.03.2008 (43) 25.08.2008  
(71) DNTN XÍ NGHIỆP MUỐI VÀ GIA VỊ THỰC PHẨM ĐỒNG LỢI (VN)  
Số 73 Võ Thị Sáu, thành phố Phan Thiết, tỉnh Bình Thuận  
(72) La Thị Mỹ Phượng (VN)  
(55)

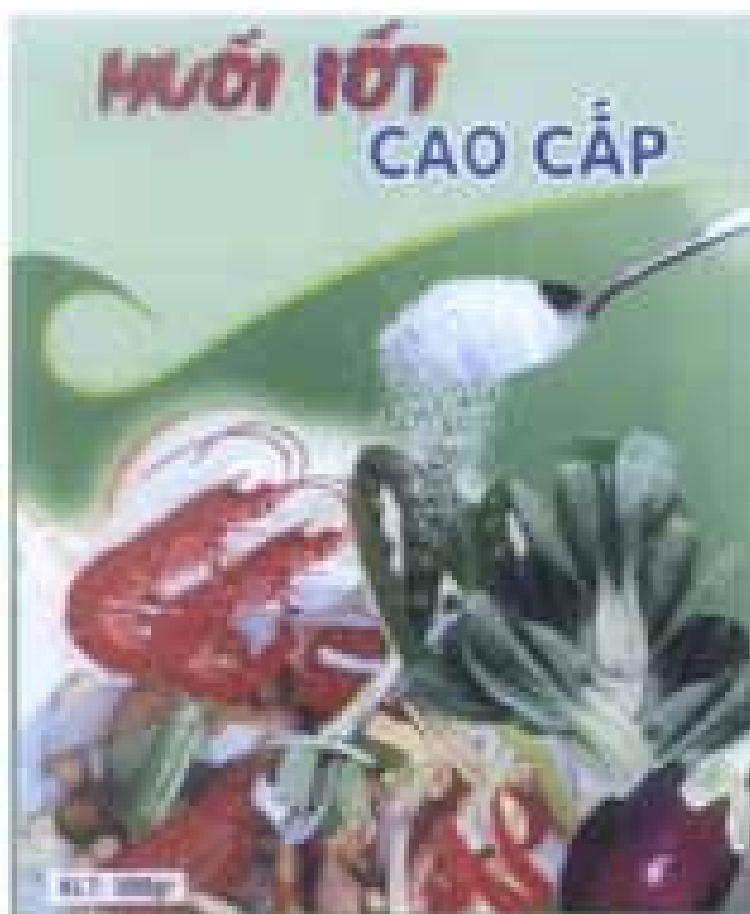

- (11) **13245**  
(21) 3-2008-00465 (28) 04  
(54) BAO GÓI (51) **09-05**  
(22) 01.04.2008 (43) 25.08.2008  
(71) CÔNG TY CỔ PHẦN ACECOOK VIỆT NAM (ACECOOK VIETNAM JSC) (VN)  
Lô II-3 đường số 11, KCN Tân Bình, phường Tây Thạnh, quận Tân Phú, TP. Hồ Chí Minh  
(72) Hoàng Cao Trí (VN)  
(74) Công ty TNHH Tư vấn sở hữu trí tuệ Việt (VIET IP CO.,LTD.)  
(55)



1.1



1.2



2.1



2.2



3.1



3.2



4.1



4.2

- (11) **13246**  
(21) 3-2008-00466 (28) 01  
(54) SÀNG RUNG (51) **15-99**  
(22) 29.05.2007 (43) 25.08.2008  
(71) CÔNG TY CỔ PHẦN CƠ KHÍ MẠO KHÊ (VN)  
Thị trấn Mạo Khê, huyện Đông Triều, tỉnh Quảng Ninh  
(72) Mai Ngọc Luật (VN), Đặng Văn Phối (VN), Phạm Việt Cường (VN)  
(74) Công ty TNHH Sở hữu trí tuệ Gia Việt (GIAVIET CO., LTD.)  
(55)



1.1

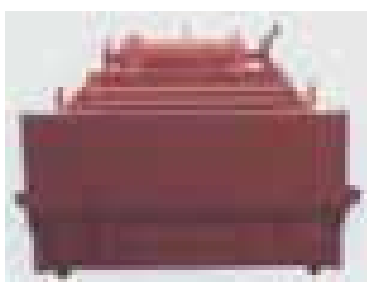

1.2



1.3

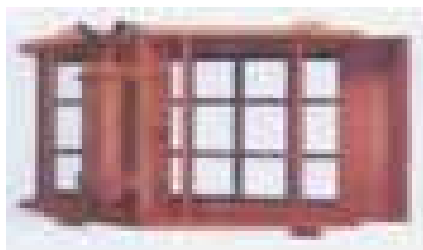

1.4

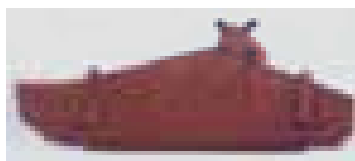

1.5

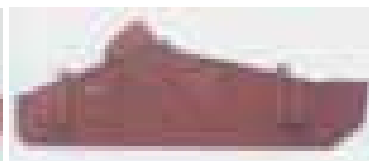

1.6

- (11) **13247**  
(21) 3-2008-00467 (28) 01  
(54) SÀNG RUNG (51) **15-99**  
(22) 29.05.2007 (43) 25.08.2008  
(71) CÔNG TY CỔ PHẦN CƠ KHÍ MẠO KHÊ (VN)  
Thị trấn Mạo Khê, huyện Đông Triều, tỉnh Quảng Ninh  
(72) Mai Ngọc Luật (VN), Đặng Văn Phối (VN), Phạm Việt Cường (VN)  
(74) Công ty TNHH Sở hữu trí tuệ Gia Việt (GIAVIET CO., LTD.)  
(55)



1.1

1.2



1.3

1.4

1.5

- (11) **13248**  
(21) 3-2008-00469 (28) 01  
(54) ÁO MƯA (51) **02-02**  
(22) 01.04.2008 (43) 25.08.2008  
(71) CÔNG TY TNHH XÂY DỰNG - THƯƠNG MẠI - DỊCH VỤ - SẢN XUẤT - XUẤT  
NHẬP KHẨU QUANG VINH (VN)  
2900 Phạm Thế Hiển, phường 7, quận 8, TP. Hồ Chí Minh  
(72) Lê Thị Thu Nga (VN)  
(74) Công ty Cổ phần Sở hữu công nghiệp INVESTIP (INVESTIP)  
(55)



1.1



1.2

1.3



- (11) **13249**  
(21) 3-2008-00471 (28) 01  
(54) LƯỢC (51) **04-01**  
(22) 01.04.2008 (43) 25.08.2008  
(30) 29/292240 03.10.2007 US  
(71) UNILEVER N.V. (NL)  
Weena 455, 3013 AL Rotterdam, Netherlands  
(72) Jeffrey Silver TAGGART (US), Jeffrey M. KALMAN (US), John Richard NOTTINGHAM (US), John Wilford SPIRK (US), Jay TAPPER (US), Rachel Marie NOTTINGHAM (US), Carolyn Marie McNEELEY (US), Richard SKINNER (GB), Brian Douglas WALL (GB), Stephen Lee WIRE (GB)  
(74) Công ty TNHH Trần Hữu Nam và Đồng sự (TRAN H.N & ASS.)  
(55)



1.1

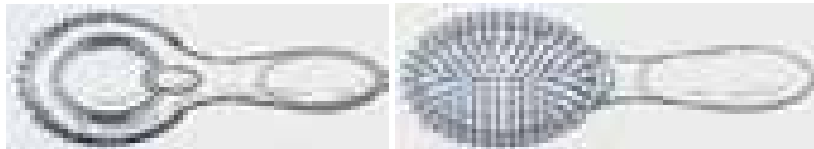

1.2

1.3



1.4

1.5

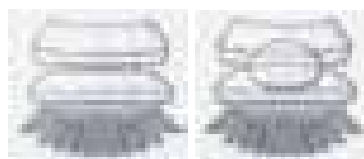

1.6

1.7

(11) **13250**

(21) 3-2008-00473

(54) HỘP ĐỰNG KHOÁ

(22) 02.04.2008

(71) BU DA WEN (CN)

No. 38, Keng Chaotun, Shaoping Village, Xiashi Town, Pingxiang City, Guangxi Province, P.R. China

(72) Bu Da Wen (CN)

(74) Công ty TNHH Sở hữu trí tuệ WINCO (WINCO CO., LTD.)

(55)

(28) 01

(51) **09-03**

(43) 25.08.2008



1.1



1.2

- (11) **13251**  
(21) 3-2008-00497 (28) 01  
(54) NẤP ĐẬY DỤNG CỤ NẤU ĂN (51) **07-02**  
(22) 08.04.2008 (43) 25.08.2008  
(71) PARK MIN GYU (KR)  
143, Ungdal-ri, Jangyou-men, Kimhae-city, Kyungnam, Korea  
(72) Park Min Gyu (KR)  
(74) Công ty Tư vấn đầu tư và chuyển giao công nghệ (INVESTCONSULT)  
(55)



1.1

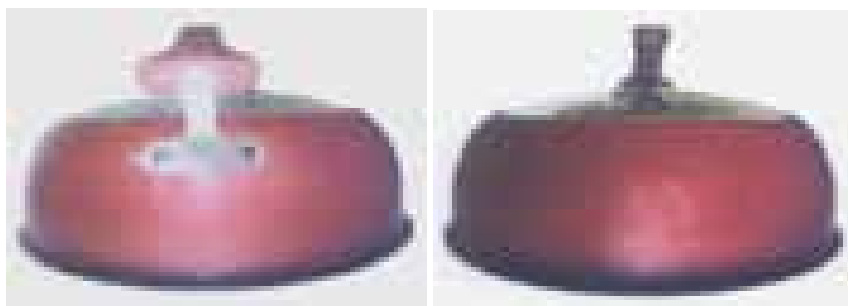

1.2

1.3



1.3

1.5



1.6

1.7

- (11) **13252**  
(21) 3-2008-00514  
(54) LỌ  
(22) 09.04.2008  
(71) XÍ NGHIỆP TƯ NHÂN THANH LONG (VN)  
44/109 Phạm Ngũ Lão, thành phố Hải Dương  
(72) Nguyễn Thành Long (VN)  
(55)
- (28) 01  
(51) **09-01**  
(43) 25.08.2008



1.1

1.2

1.3



1.4

1.5

1.6

- (11) **13253**  
(21) 3-2008-00543 (28) 01  
(54) BÓNG ĐÈN (51) **26-04**  
(22) 17.04.2008 (43) 25.08.2008  
(30) 000812359-0004 19.10.2007 EM  
(71) KONINKLIJKE PHILIPS ELECTRONICS N.V. (NL)  
Groenewoudseweg 1, 5621 BA Eindhoven, The Netherlands  
(72) Ernest Kin Man To (CN), Nan Zhao (CN)  
(74) Công ty Cổ phần Sở hữu công nghiệp INVESTIP (INVESTIP)  
(55)



1.1

1.2

1.3

1.4



1.5

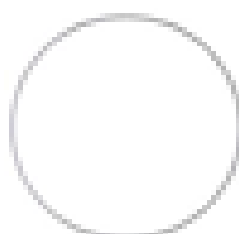

1.6

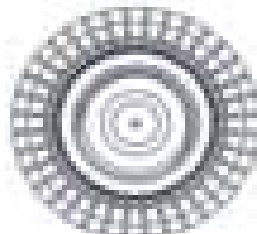

1.7

- (11) **13254**  
(21) 3-2008-00548 (28) 01  
(54) KHUNG XE ĐẨY TAY (51) **12-02**  
(22) 18.04.2008 (43) 25.08.2008  
(71) PRESTAR MANUFACTURING SDN BHD (MY)  
Lot 39, Rawang Industrial Estate, 16 1/2 Miles, Jalan Ipoh, 48000 Rawang, Selangor  
Darul Ehsan, Malaysia  
(72) Toh Yew Seng (MY)  
(74) Công ty TNHH Tầm nhìn và Liên danh (VISION & ASSOCIATES CO.LTD.)  
(55)

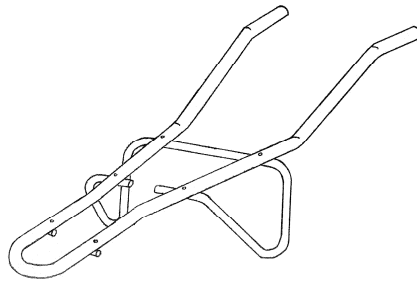

1.1

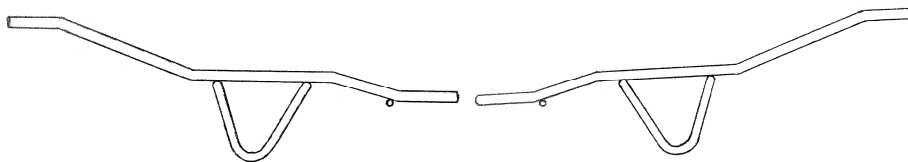

1.2

1.3

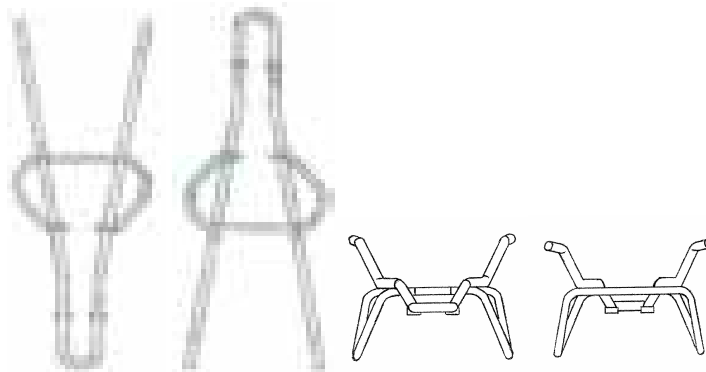

1.4

1.5

1.6

1.7

- (11) **13255**  
(21) 3-2008-00552 (28) 01  
(54) HỘP ĐỰNG THUỐC (51) **09-03**  
(22) 21.04.2008 (43) 25.08.2008  
(71) CÔNG TY CỔ PHẦN DƯỢC TW MEDIPLANTEX (VN)  
358 đường Giải Phóng, phường Phương Liệt, quận Thanh Xuân, thành phố Hà Nội  
(72) Trần Bình Duyên (VN)  
(74) Công ty TNHH Sở hữu trí tuệ PADEMARK (PADEMARK CO.,LTD.)  
(55)



1.1



1.2



- (11) **13256**  
(21) 3-2008-00561 (28) 01  
(54) GẠCH (51) **25-01**  
(22) 22.04.2008 (43) 25.08.2008  
(71) NGUYỄN HUY HOÀNG (VN)  
290/30/3 tổ 23 khu phố 2, phường Hiệp Thành, quận 12, TP. Hồ Chí Minh  
(72) Nguyễn Huy Hoàng (VN)  
(55)



1.1



1.2

1.3

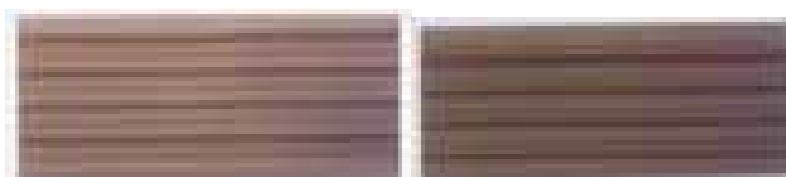

1.4

1.5



1.6

1.7

- (11) **13257**  
(21) 3-2008-00571 (28) 02  
(54) TỦ NHỰA (51) **06-04**  
(22) 23.04.2008 (43) 25.08.2008  
(71) CÔNG TY CỔ PHẦN ĐẠI ĐỒNG TIẾN (VN)  
216 Tân Thành, phường 15, quận 5, TP. Hồ Chí Minh  
(72) Trịnh Đông (VN)  
(74) DNTN Dịch vụ thương mại và sở hữu công nghiệp Song Ngọc (I.P.T.S.)  
(55)

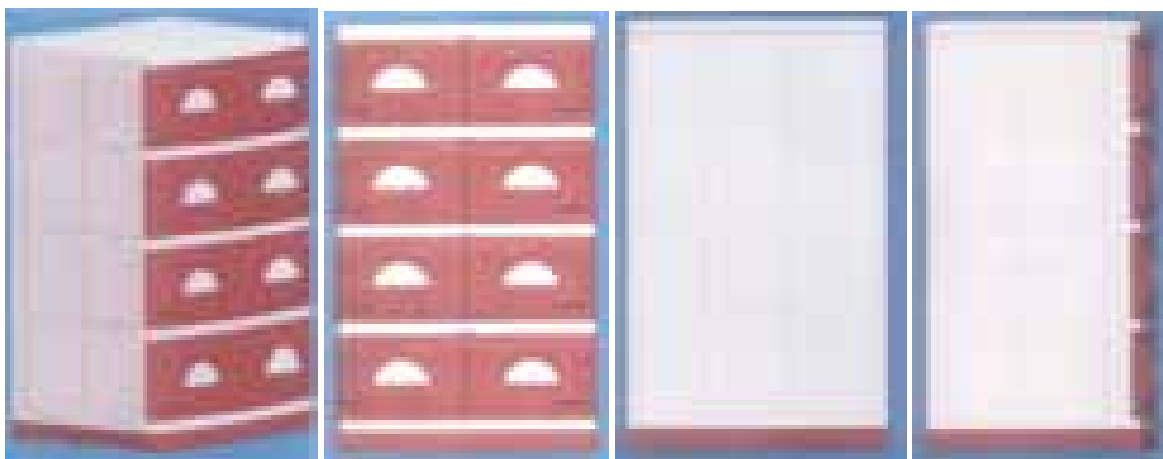

1.1

1.2

1.3

1.4

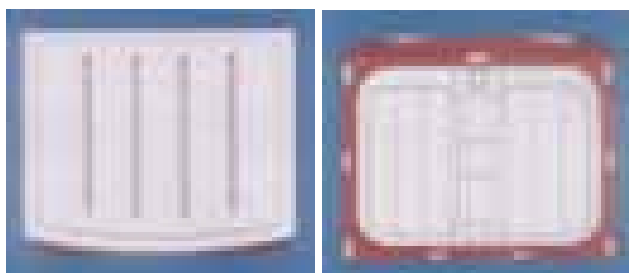

1.5

1.6

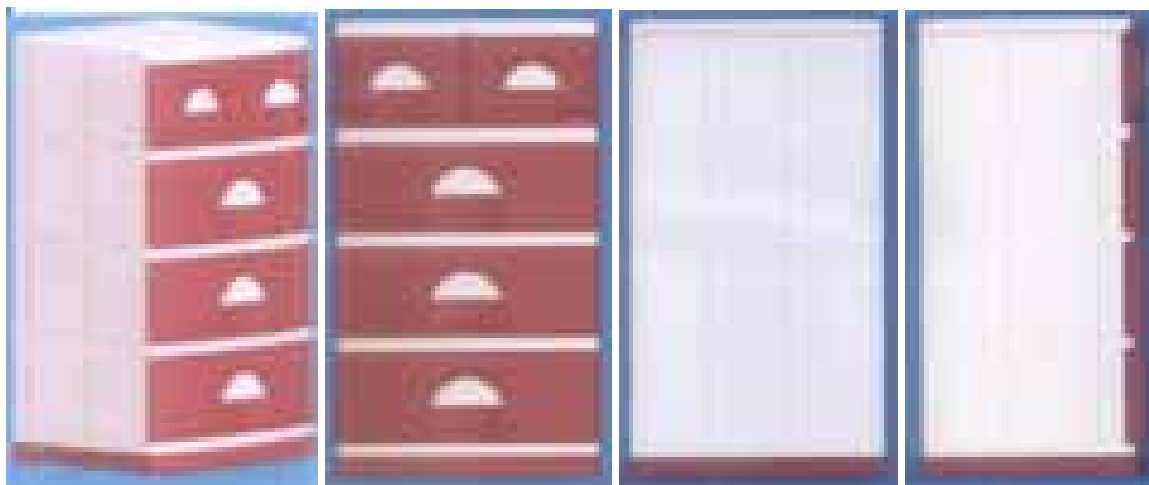

2.1

2.2

2.3

2.4

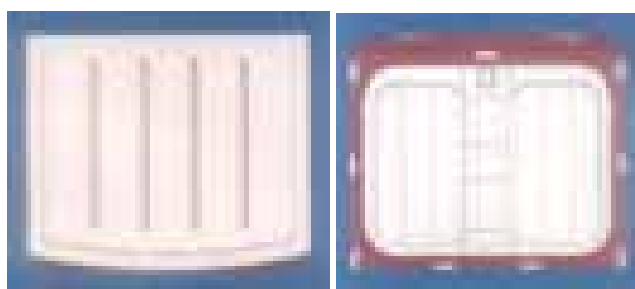

2.5

2.6

- (11) **13258**  
(21) 3-2008-00576 (28) 01  
(54) BAO GÓI (51) **09-05**  
(22) 23.04.2008 (43) 25.08.2008  
(71) CÔNG TY TNHH THUỐC THÚ Y THỦY SẢN AN ĐẠI PHÁT (VN)  
72/11 đường 138, ấp Cây Dầu, phường Tân Phú, quận 9, TP. Hồ Chí Minh  
(72) Đoàn Phổ (VN)  
(74) Công ty Cổ phần Sở hữu công nghiệp INVESTIP (INVESTIP)  
(55)



1.1



1.2

- (11) **13259**  
(21) 3-2008-00586 (28) 01  
(54) THÙNG RÁC (51) **09-09**  
(22) 28.04.2008 (43) 25.08.2008  
(30) 000815972-0001 26.10.2007 EM  
(71) BRABANTIA NEDERLAND B.V. (NL)  
Brabantiaalaan 3, 5583 BP WaaLre, The Netherlands  
(72) Jolijn Marion Schoofs (NL)  
(74) Công ty TNHH Sở hữu trí tuệ Thảo Quyến (INVENCO)  
(55)

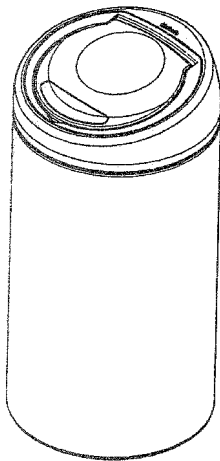

1.1

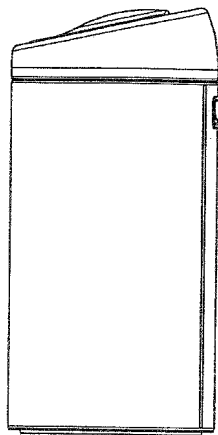

1.2

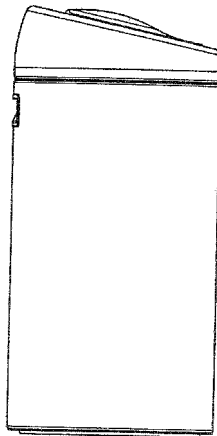

1.3

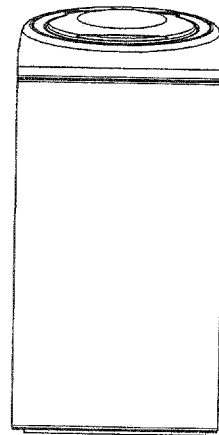

1.4

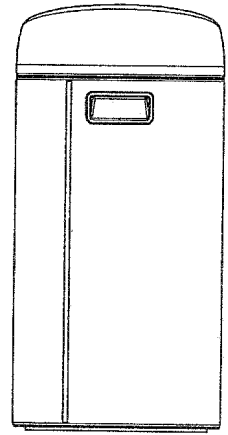

1.5

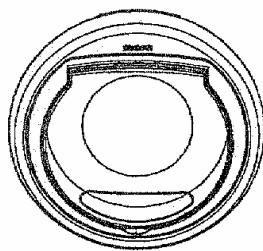

1.6

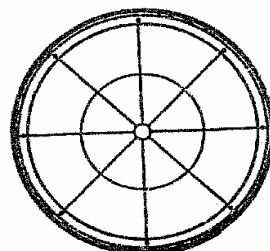

1.7

- (11) **13260**  
(21) 3-2008-00598 (28) 01  
(54) CHAI (51) **09-01**  
(22) 29.04.2008 (43) 25.08.2008  
(30) 200730321446.5 08.11.2007 CN  
(71) SICHUAN WENJUN SPIRITS COMPANY LIMITED (CN)  
No. 33, East Ring Road, Linqiong Town, Qionglai City, Chengdu City, Sichuan  
Province, China  
(72) Neil HIRST (GB), Edward MITCHELL (GB)  
(74) Công ty TNHH Tâm nhìn và Liên danh (VISION & ASSOCIATES CO.LTD.)  
(55)



1.1

1.2

1.3

1.4

1.5



1.6

1.7

- (11) **13261**  
(21) 3-2008-00599 (28) 01  
(54) **VỈ ĐỤNG DỤNG CỤ HÚT MŨI** (51) **09-05**  
**TRẺ EM**  
(22) 29.04.2008 (43) 25.08.2008  
(71) **LÊ KIM ANH (VN)**  
204 A4 Nam Thành Công, Láng Hạ, quận Đống Đa, thành phố Hà Nội  
(72) Lê Kim Anh (VN)  
(74) Công ty TNHH Vĩnh Đạt (LACOM CO., LTD.)  
(55)



1.1

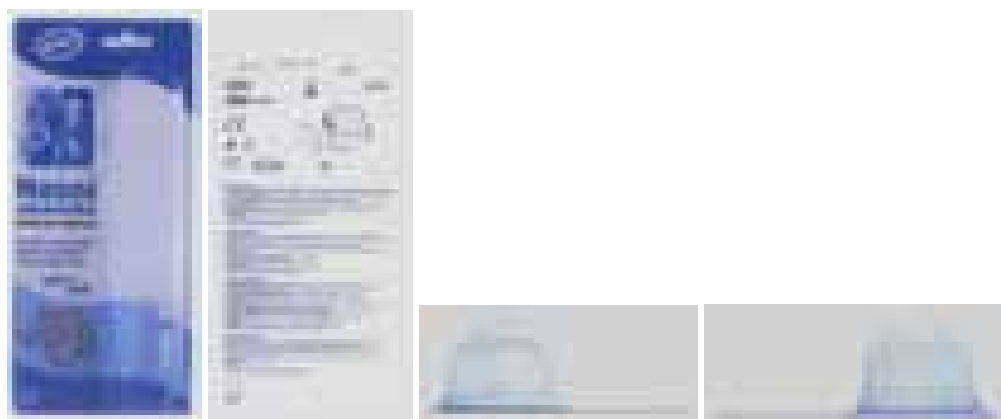

1.2

1.3

1.4

1.5

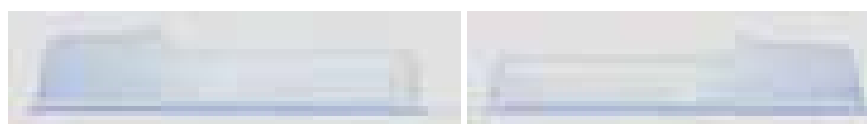

1.6

1.7

- (11) **13262**  
(21) 3-2008-00613 (28) 01  
(54) BÓNG ĐÈN ĐUI VẶN (51) **26-04**  
(22) 07.05.2008 (43) 25.08.2008  
(71) CÔNG TY TRÁCH NHIỆM HỮU HẠN THANH NIÊN (VN)  
Số 16 Văn Cao, thành phố Đà Nẵng  
(72) Nguyễn Đắc Linh (VN)  
(74) Công ty TNHH Sở hữu trí tuệ Thảo Thọ Quyển (INVENCO)  
(55)



1.1

1.2

1.3

1.4

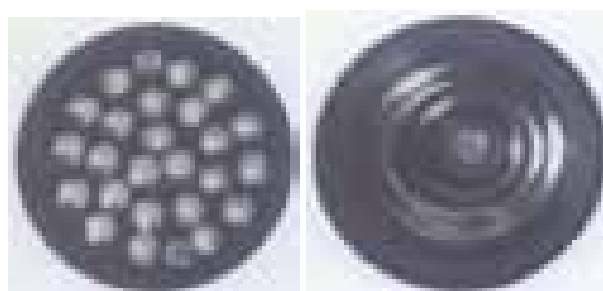

1.5

1.6



- (11) **13263**  
(21) 3-2008-00625 (28) 01  
(54) HỘP (51) **09-03**  
(22) 09.05.2008 (43) 25.08.2008  
(71) CÔNG TY TNHH MỸ PHẨM CHÂU Á (VN)  
490/23 Phạm Văn Chí, phường 8, quận 6, TP. Hồ Chí Minh  
(72) Trang Chí Cường (VN)  
(74) Công ty TNHH Tư vấn sở hữu trí tuệ Việt (VIET IP CO.,LTD.)  
(55)



1.1



1.2

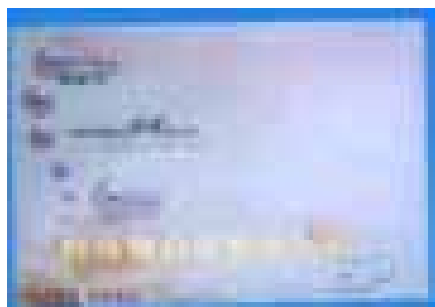

1.3

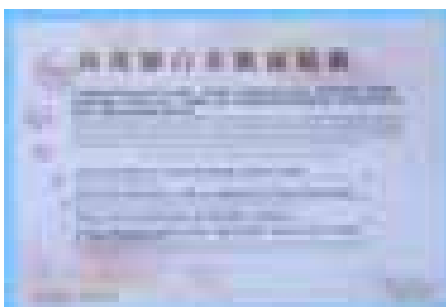

1.4

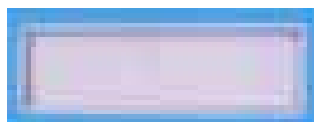

1.5

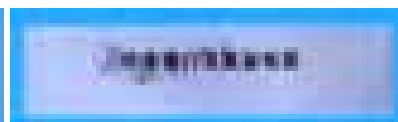

1.6

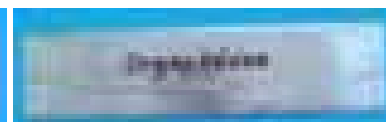

1.7

- (11) **13264**  
(21) 3-2008-00626 (28) 01  
(54) HỘP (51) **09-03**  
(22) 09.05.2008 (43) 25.08.2008  
(71) CÔNG TY TNHH MỸ PHẨM CHÂU Á (VN)  
490/23 Phạm Văn Chí, phường 8, quận 6, TP. Hồ Chí Minh  
(72) Trang Chí Cường (VN)  
(74) Công ty TNHH Tư vấn sở hữu trí tuệ Việt (VIET IP CO.,LTD.)  
(55)



1.1



1.2



1.3



1.4

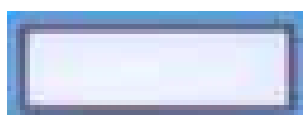

1.5

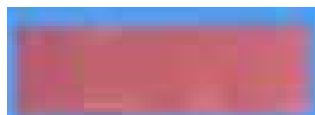

1.6

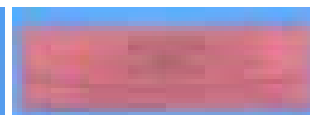

1.7

- (11) **13265**  
(21) 3-2008-00627 (28) 01  
(54) HỘP (51) **09-03**  
(22) 09.05.2008 (43) 25.08.2008  
(71) CÔNG TY TNHH MỸ PHẨM CHÂU Á (VN)  
490/23 Phạm Văn Chí, phường 8, quận 6, TP. Hồ Chí Minh  
(72) Trang Chí Cường (VN)  
(74) Công ty TNHH Tư vấn sở hữu trí tuệ Việt (VIET IP CO.,LTD.)  
(55)



1.1



1.2



1.3

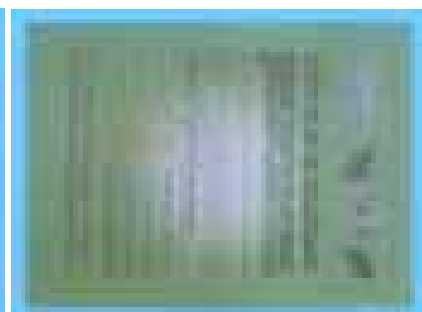

1.4

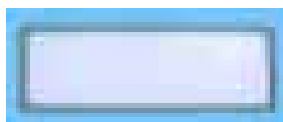

1.5



1.6

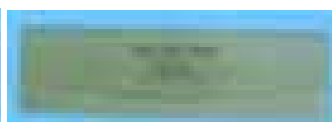

1.7

- (11) **13266**  
(21) 3-2008-00628 (28) 01  
(54) HỘP (51) **09-03**  
(22) 09.05.2008 (43) 25.08.2008  
(71) CÔNG TY TNHH MỸ PHẨM CHÂU Á (VN)  
490/23 Phạm Văn Chí, phường 8, quận 6, TP. Hồ Chí Minh  
(72) Trang Chí Cường (VN)  
(74) Công ty TNHH Tư vấn sở hữu trí tuệ Việt (VIET IP CO.,LTD.)  
(55)



1.1



1.2



1.3

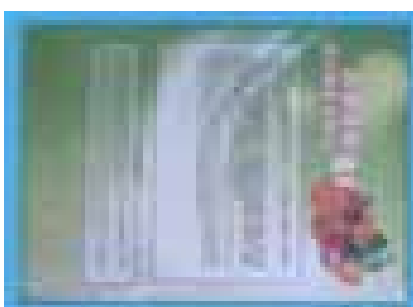

1.4

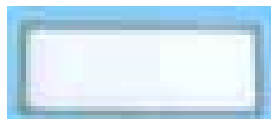

1.5



1.6

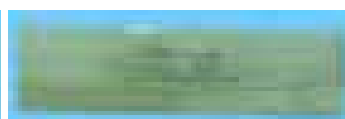

1.7

- (11) **13267**  
(21) 3-2008-00629 (28) 01  
(54) HỘP (51) **09-03**  
(22) 09.05.2008 (43) 25.08.2008  
(71) CÔNG TY TNHH MỸ PHẨM CHÂU Á (VN)  
490/23 Phạm Văn Chí, phường 8, quận 6, TP. Hồ Chí Minh  
(72) Trang Chí Cường (VN)  
(74) Công ty TNHH Tư vấn sở hữu trí tuệ Việt (VIET IP CO.,LTD.)  
(55)



1.1



1.2



1.3



1.4

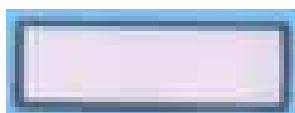

1.5



1.6



1.7

- (11) **13268**  
(21) 3-2008-00631 (28) 01  
(54) MÁY SẤY KHÔ TAY (51) **28-03**  
(22) 12.05.2008 (43) 25.08.2008  
(30) 2007-031354 13.11.2007 JP  
(71) MITSUBISHI ELECTRIC CORPORATION (JP)  
7-3, Marunouchi 2-Chome, Chiyoda-Ku, Tokyo, 100-8310 Japan  
(72) Hiroyuki KATO (JP), Kei KASUGA (JP)  
(74) Công ty Cổ phần Sở hữu công nghiệp INVESTIP (INVESTIP)  
(55)

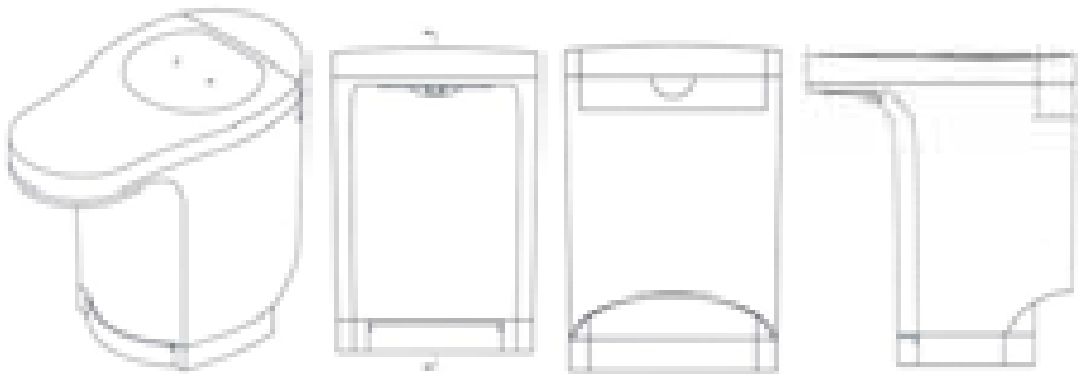

1.1

1.2

1.3

1.4

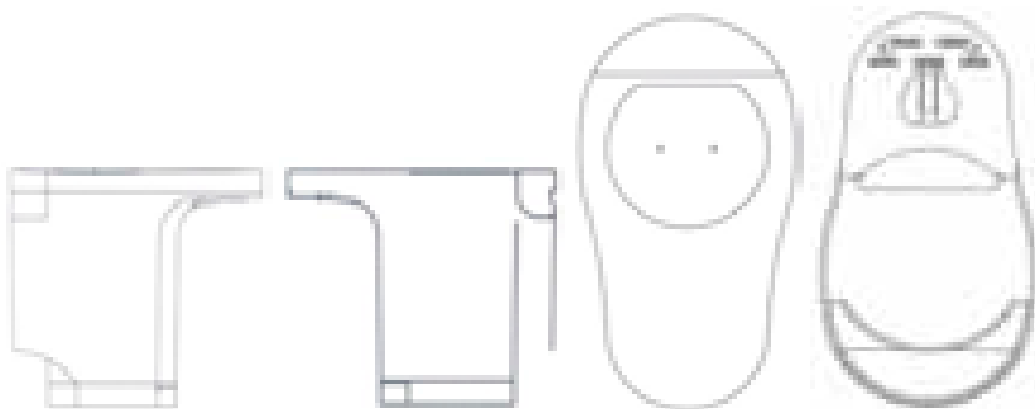

1.5

1.6

1.7

1.8

- (11) **13269**  
(21) 3-2008-00632 (28) 01  
(54) MÁY SẤY KHÔ TAY (51) **28-03**  
(22) 12.05.2008 (43) 25.08.2008  
(30) 2007-031353 13.11.2007 JP  
(71) MITSUBISHI ELECTRIC CORPORATION (JP)  
7-3, Marunouchi 2-Chome, Chiyoda-Ku, Tokyo, 100-8310 Japan  
(72) Hiroyuki KATO (JP), Kei KASUGA (JP)  
(74) Công ty Cổ phần Sở hữu công nghiệp INVESTIP (INVESTIP)  
(55)

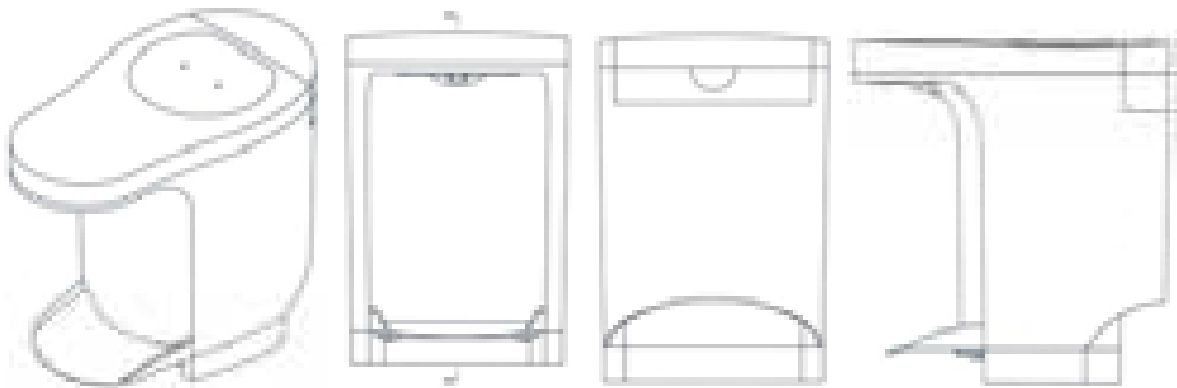

1.1

1.2

1.3

1.4

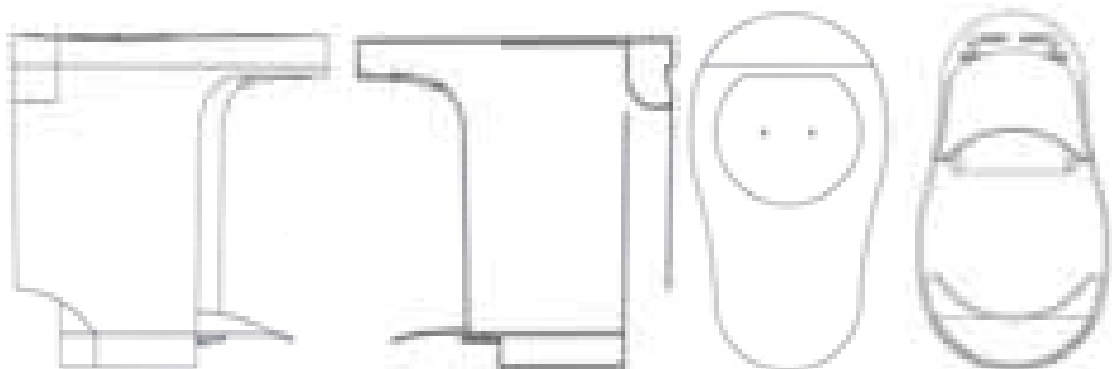

1.5

1.6

1.7

1.8

- (11) **13270**  
(21) 3-2008-00633 (28) 01  
(54) XE MÁY (51) **12-11**  
(22) 12.05.2008 (43) 25.08.2008  
(71) PIAGGIO & C. S.P.A. (IT)  
Viale Rinaldo Piaggio 25, 56025 PONTEDERA (Pisa), Italy  
(72) Marco LAMBRI (IT)  
(74) Công ty Cổ phần Sở hữu công nghiệp INVESTIP (INVESTIP)  
(55)



1.1



1.2



1.3



1.4



1.5





1.6

1.7

1.8



1.9

1.10

- (11) **13271**  
(21) 3-2008-00646 (28) 01  
(54) BAO GÓI KẸO (51) **09-05**  
(22) 13.05.2008 (43) 25.08.2008  
(71) ĐÀO VĂN QUY (VN)  
Số 56 tổ 6B phường Đức Giang, quận Long Biên, thành phố Hà Nội  
(72) Đào Văn Quy (VN)  
(74) Công ty TNHH Sở hữu trí tuệ HA VIP (HAVIP CO., LTD.)  
(55)



1.1



1.2

- (11) **13272**  
(21) 3-2008-00647 (28) 01  
(54) BAO GÓI KẸO (51) **09-05**  
(22) 13.05.2008 (43) 25.08.2008  
(71) ĐÀO VĂN QUY (VN)  
Số 56 tổ 6B phường Đức Giang, quận Long Biên, thành phố Hà Nội  
(72) Đào Văn Quy (VN)  
(74) Công ty TNHH Sở hữu trí tuệ HA VIP (HAVIP CO., LTD.)  
(55)

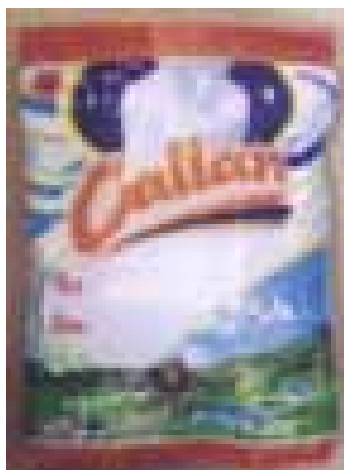

1.1



1.2

- (11) **13273**  
(21) 3-2008-00649 (28) 01  
(54) BẢNG ĐIỆN (51) **13-03**  
(22) 14.05.2008 (43) 25.08.2008  
(71) CƠ SỞ HUNG PHÁT (VN)  
228/62 Hàn Hải Nguyên, phường 9, quận 11, TP. Hồ Chí Minh  
(72) Huỳnh Đệ Đệ (VN)  
(74) DNTN Dịch vụ thương mại và sở hữu công nghiệp Song Ngọc (I.P.T.S.)  
(55)



1.1



1.2

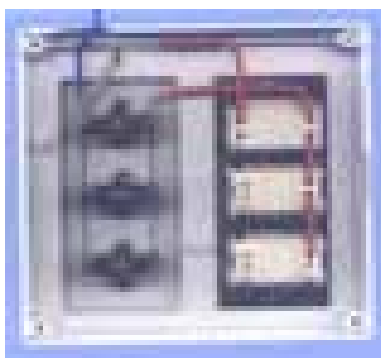

1.3



1.4



1.5



1.6



1.7

- (11) **13274**  
(21) 3-2008-00650 (28) 01  
(54) ĐẦU GẬY CHƠI GÔN (51) **21-02**  
(22) 14.05.2008 (43) 25.08.2008  
(30) 29/299127 19.12.2007 US  
(71) KARSTEN MANUFACTURING CORPORATION (US)  
2201 West Desert Cove, Phoenix, Arizona 85029, United States of America  
(72) Anthony D. Serrano (US), Eric J. Morales (US), Xiaojian Chen (CN)  
(74) Công ty TNHH Sở hữu trí tuệ Vàng (GINTASSET CO., LTD.)  
(55)

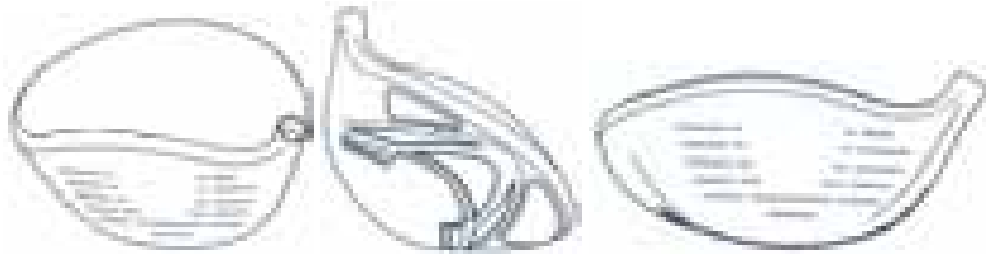

1.1

1.2

1.3



1.4

1.5

1.6



1.7

1.8

1.9

- (11) **13275**  
(21) 3-2008-00652 (28) 01  
(54) MÁY HÀN LỒNG CỐT THÉP ĐIỀU KHIỂN CNC (51) **15-99**  
(22) 15.05.2008 (43) 25.08.2008  
(71) VIỆN MÁY VÀ DỤNG CỤ CÔNG NGHIỆP (VN)  
46 Láng Hạ, quận Đống Đa, thành phố Hà Nội  
(72) Trương Hữu Trí (VN)  
(74) Công ty TNHH Sở hữu trí tuệ WINCO (WINCO CO., LTD.)  
(55)

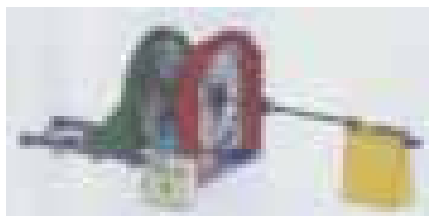

1.1

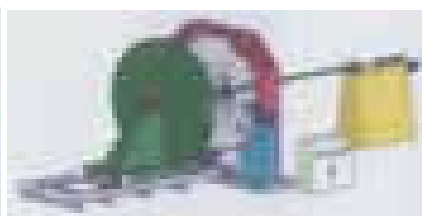

1.2

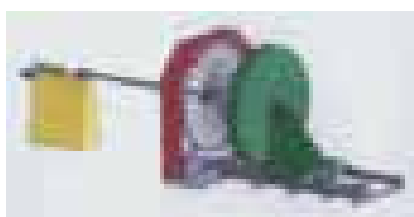

1.3

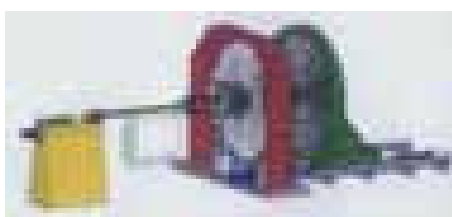

1.4

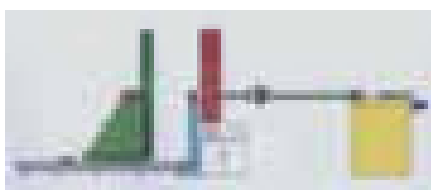

1.5

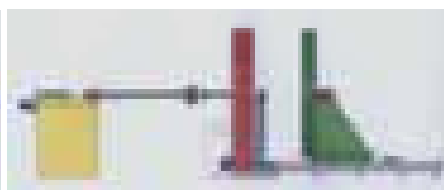

1.6

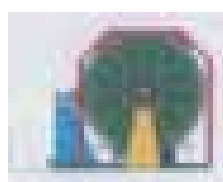

1.7

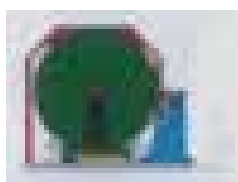

1.8

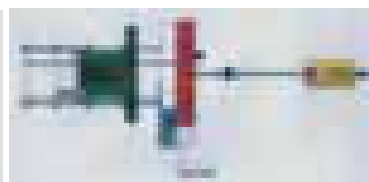

1.9

- (11) **13276**  
(21) 3-2008-00653 (28) 01  
(54) **HỆ THỐNG LỌC VÀ OZON HOÁ MÔI TRƯỜNG** (51) **23-01**  
(22) 15.05.2008 (43) 25.08.2008  
(30) 08-00441-0101 19.03.2008 MY  
(71) **WISPAC INDUSTRY SDN. BHD. (MY)**  
No. 6, Jalan BK 1/13, Kinrara Industrial Park, Bandar Kinrara, 47100 Puchong,  
Selangor, Malaysia  
(72) **Soh Tiam Ee (MY)**  
(74) **Công ty TNHH Quốc tế D & N (D&N INTERNATIONAL CO.,LTD.)**  
(55)

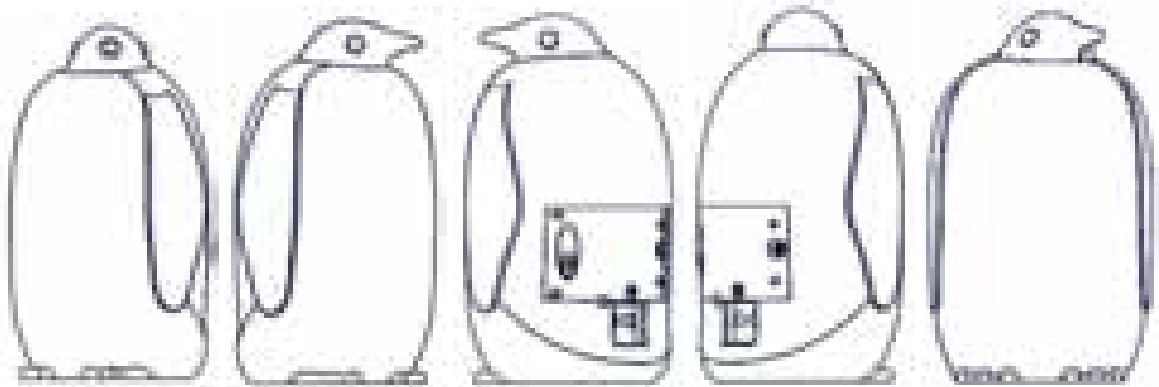

1.1

1.2

1.3

1.4

1.5



1.6

1.7

1.8

1.9

1.10

- (11) **13277**  
(21) 3-2008-00655 (28) 01  
(54) CÔNG TẮC (51) **13-03**  
(22) 16.05.2008 (43) 25.08.2008  
(30) 2007-031823 19.11.2007 JP  
(71) MATSUSHITA ELECTRIC WORKS, LTD. (JP)  
1048, Oaza Kadoma, Kadoma-shi, OSAKA 571-8686, Japan  
(72) KATSUMI KIKUCHI (JP), ICHIRO SHIBAMURA (JP)  
(74) Công ty Luật TNHH AMBYS Hà Nội (AMBYS HANOI)  
(55)

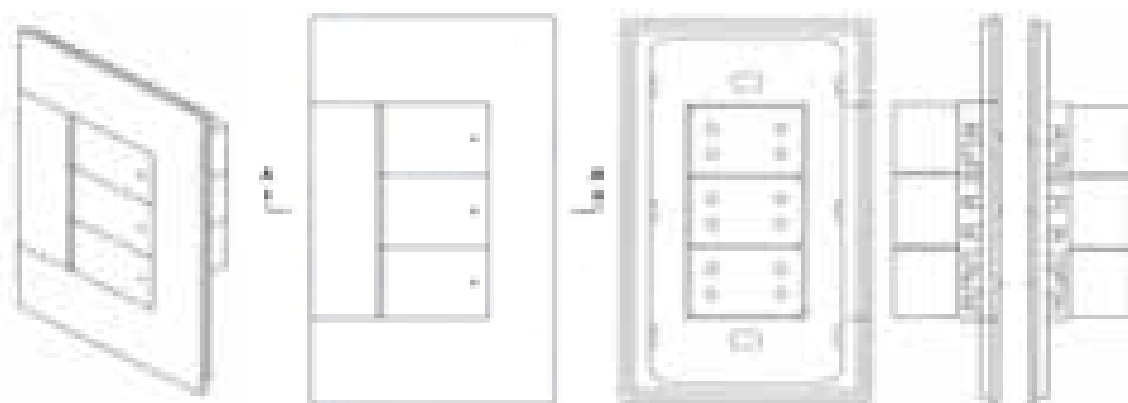

1.1

1.2

1.3

1.4

1.5



1.6

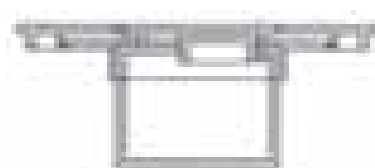

1.7



- (11) **13278**  
(21) 3-2008-00656 (28) 01  
(54) CÔNG TẮC (51) **13-03**  
(22) 16.05.2008 (43) 25.08.2008  
(30) 2007-031821 19.11.2007 JP  
(71) MATSUSHITA ELECTRIC WORKS, LTD. (JP)  
1048, Oaza Kadoma, Kadoma-shi, OSAKA 571-8686, Japan  
(72) KATSUMI KIKUCHI (JP), ICHIRO SHIBAMURA (JP)  
(74) Công ty Luật TNHH AMBYS Hà Nội (AMBYS HANOI)  
(55)

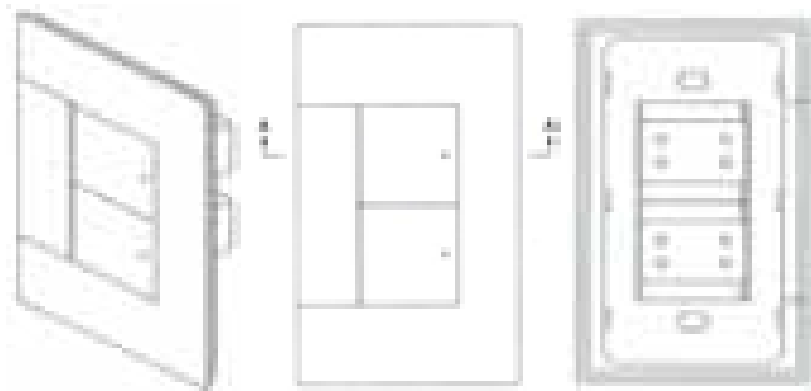

1.1

1.2

1.3



1.4

1.5

1.6

1.7

- (11) **13279**  
(21) 3-2008-00657 (28) 01  
(54) CÔNG TẮC (51) **13-03**  
(22) 16.05.2008 (43) 25.08.2008  
(30) 2007-031824 19.11.2007 JP  
(71) MATSUSHITA ELECTRIC WORKS, LTD. (JP)  
1048, Oaza Kadoma, Kadoma-shi, OSAKA 571-8686, Japan  
(72) KATSUMI KIKUCHI (JP), ICHIRO SHIBAMURA (JP)  
(74) Công ty Luật TNHH AMBYS Hà Nội (AMBYS HANOI)  
(55)

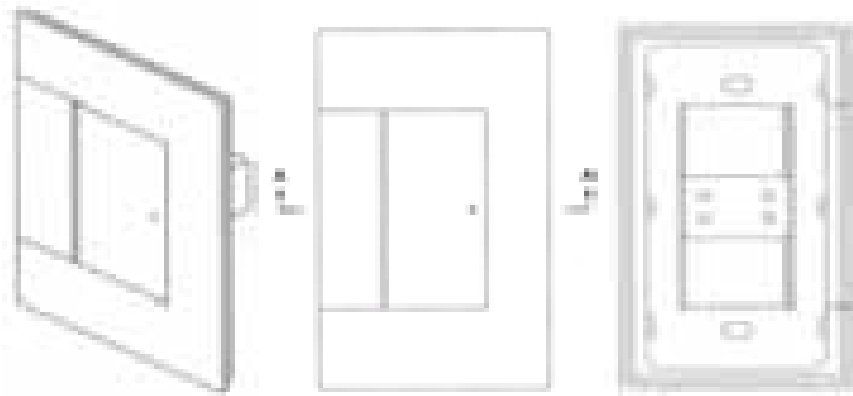

1.1

1.2

1.3



1.4 1.5

1.6

1.7

- (11) **13280**  
(21) 3-2008-00661 (28) 01  
(54) LON ĐỰNG ĐỒ UỐNG (51) **09-03**  
(22) 16.05.2008 (43) 25.08.2008  
(71) CÔNG TY CỔ PHẦN THƯƠNG MẠI TÂN TIẾN PHÁT (VN)  
Đội 7B, xóm Me Táo, xã Dương Liễu, huyện Hoài Đức, tỉnh Hà Tây  
(72) Nguyễn Bá Vinh (VN)  
(74) Công ty TNHH Nghiên cứu và Tư vấn chuyển giao công nghệ và đầu tư (CONCETTI)  
(55)



1.1

1.2

1.3

1.4



1.5

1.6

- (11) **13281**  
(21) 3-2008-00662 (28) 01  
(54) LON ĐỰNG ĐỒ UỐNG (51) **09-03**  
(22) 16.05.2008 (43) 25.08.2008  
(71) CÔNG TY CỔ PHẦN THƯƠNG MẠI TÂN TIẾN PHÁT (VN)  
Đội 7B, xóm Me Táo, xã Dương Liễu, huyện Hoài Đức, tỉnh Hà Tây  
(72) Nguyễn Bá Vinh (VN)  
(74) Công ty TNHH Nghiên cứu và Tư vấn chuyển giao công nghệ và đầu tư (CONCETTI)  
(55)



1.1

1.2

1.3

1.4



1.5

1.6

- (11) **13282**  
(21) 3-2008-00669 (28) 01  
(54) HỘ ĐUNG SẢN PHẨM (51) **09-03**  
(22) 19.05.2008 (43) 25.08.2008  
(71) CƠ SỞ SẢN XUẤT THUỐC THÀNH PHẨM Y HỌC CỔ TRUYỀN CHÁNH ĐẠI (VN)  
295 Nguyễn Trãi, phường 7, quận 5, TP. Hồ Chí Minh  
(72) Lý Tuấn Hùng (VN)  
(74) Công ty TNHH Sở hữu trí tuệ WINCO (WINCO CO., LTD.)  
(55)



1.1



1.2

- (11) **13283**  
(21) 3-2008-00670 (28) 01  
(54) XE BUÝT (51) **12-08**  
(22) 19.05.2008 (43) 25.08.2008  
(71) YOUNG MAN AUTOMOBILE GROUP CO., LTD. (CN)  
No. 501 BaDa Road, JinHua, ZheJiang, P.R.China  
(72) Pang Qing Nian (CN)  
(74) Công ty TNHH Sở hữu trí tuệ WINCO (WINCO CO., LTD.)  
(55)



1.1



1.2



1.3

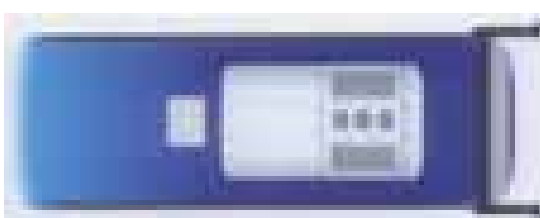

1.4

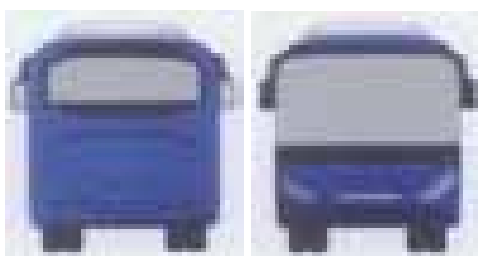

1.5



1.6

- (11) **13284**  
(21) 3-2008-00671 (28) 01  
(54) XE TẢI (51) **12-08**  
(22) 19.05.2008 (43) 25.08.2008  
(30) 200830096451.5 21.04.2008 CN  
(71) YOUNG MAN AUTOMOBILE GROUP CO., LTD. (CN)  
No. 501 BaDa Road, JinHua, ZheJiang, P.R.China  
(72) Pang Qing Nian (CN)  
(74) Công ty TNHH Sở hữu trí tuệ WINCO (WINCO CO., LTD.)  
(55)



1.1

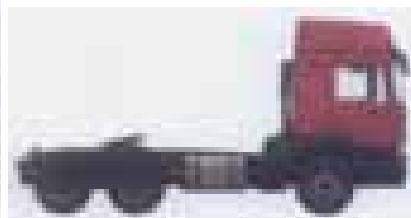

1.2



1.3

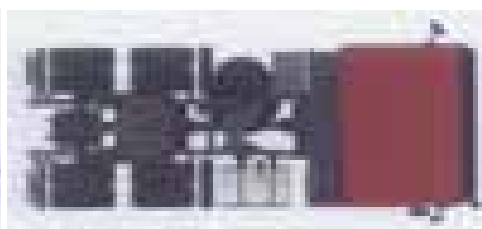

1.4

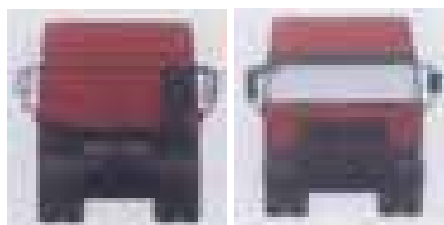

1.5

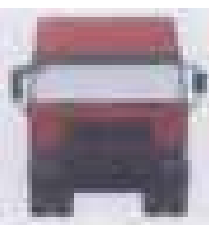

1.6

- (11) **13285**  
(21) 3-2008-00675 (28) 01  
(54) BÓNG ĐÈN (51) **26-04**  
(22) 19.05.2008 (43) 25.08.2008  
(30) 000833512 28.11.2007 EM  
(71) KONINKLIJKE PHILIPS ELECTRONICS N.V. (NL)  
Groenewoudseweg 1, 5621 BA Eindhoven, The Netherlands  
(72) Ernest Kin Man To (CN), Yongsi Bi (CN)  
(74) Công ty Cổ phần Sở hữu công nghiệp INVESTIP (INVESTIP)  
(55)

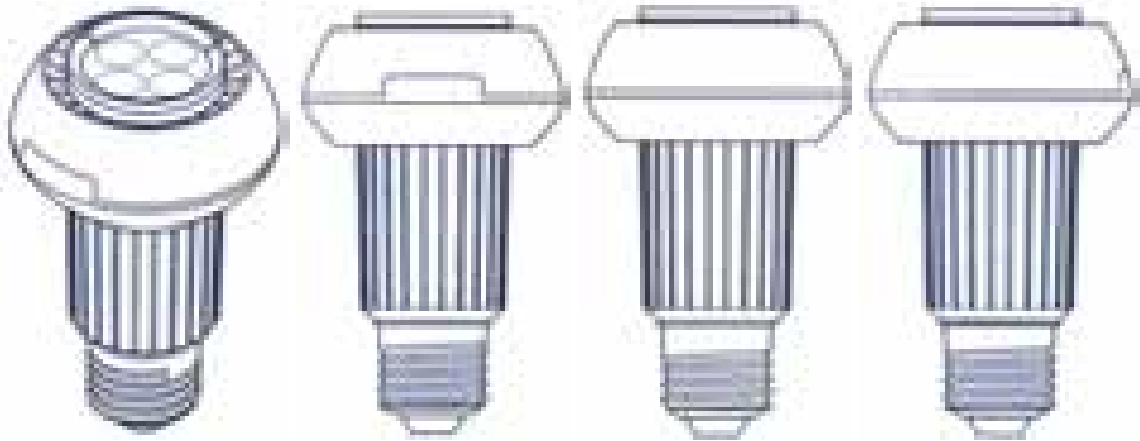

1.1

1.2

1.3

1.4

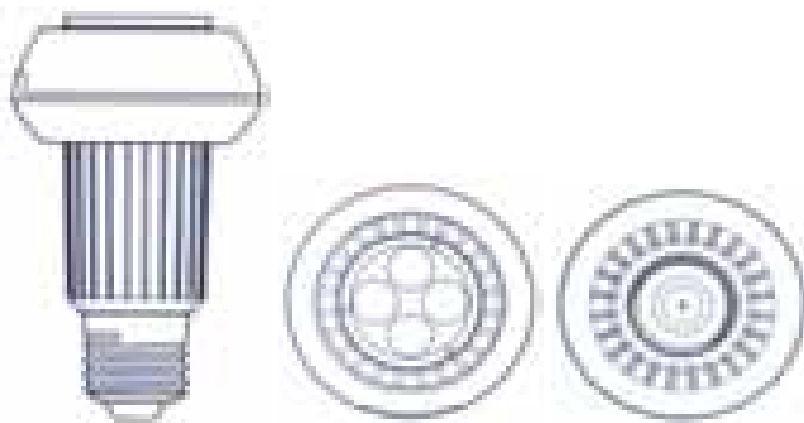

1.5

1.6

1.7



- (11) **13286**  
(21) 3-2008-00683 (28) 01  
(54) HỘP ĐỰNG ĐỒ ĐA NĂNG (51) **12-16**  
(22) 20.05.2008 (43) 25.08.2008  
(71) CÔNG TY TNHH SẢN XUẤT THƯƠNG MẠI GIÀY ĐỨC MINH (VN)  
339 Tân Hòa Đông, phường Bình Trị Đông, quận Bình Tân, TP. Hồ Chí Minh  
(72) Hoàng Đức Vũ (VN)  
(74) Công ty TNHH Sở hữu trí tuệ WINCO (WINCO CO., LTD.)  
(55)



1.1

1.2

1.3



1.4

1.5

1.6



1.7

- (11) **13287**  
(21) 3-2008-00685 (28) 01  
(54) BÓNG ĐÈN (51) **26-04**  
(22) 20.05.2008 (43) 25.08.2008  
(71) CÔNG TY TRÁCH NHIỆM HỮU HẠN THANH NIÊN (VN)  
Số 16 Văn Cao, thành phố Đà Nẵng  
(72) Nguyễn Đắc Linh (VN)  
(74) Công ty TNHH Sở hữu trí tuệ Thảo Thọ Quyến (INVENCO)  
(55)

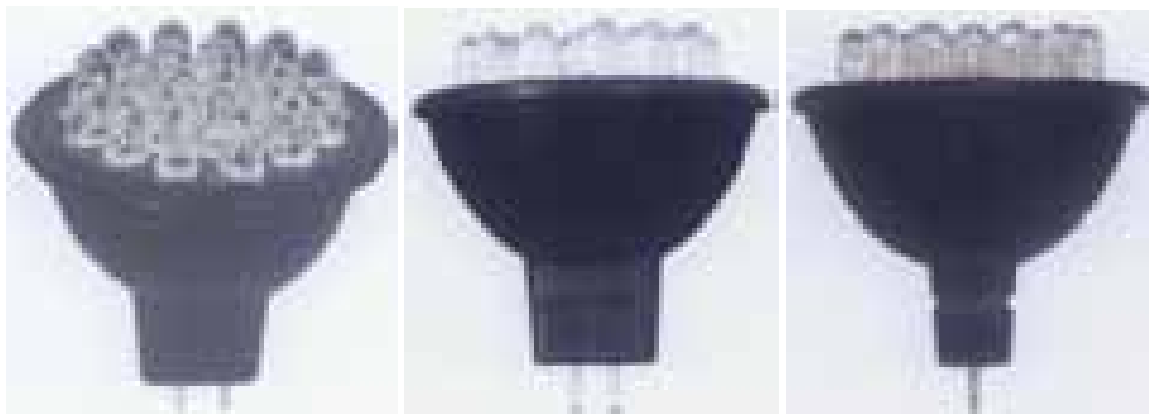

1.1

1.2

1.3

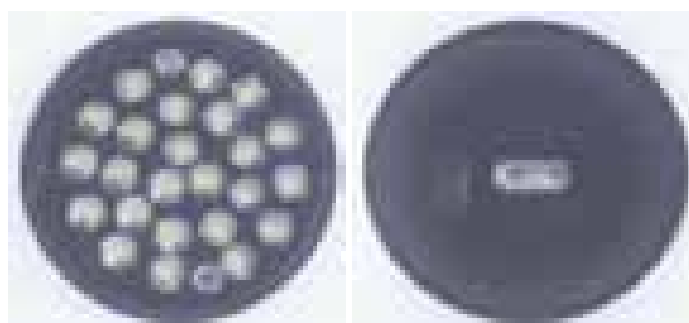

1.4

1.5

- (11) **13288**  
(21) 3-2008-00686 (28) 01  
(54) THIẾT BỊ ĐIỀU KHIỂN MÀN HÌNH (51) **06-10**  
MÀN HÌNH  
(22) 20.05.2008 (43) 25.08.2008  
(30) 000831367-0001 20.11.2007 EM  
(71) HUNTER DOUGLAS INDUSTRIES B.V. (NL)  
Dutch body corporate of Piekstraat 2, NL-3071 EL Rotterdam, The Netherlands  
(72) Stefanus Franciscus Wilhelmus JOOSTEN (NL)  
(74) Công ty TNHH Sở hữu trí tuệ Vàng (GINTASSET CO., LTD.)  
(55)

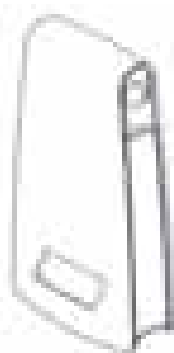

1.1



1.2



1.3

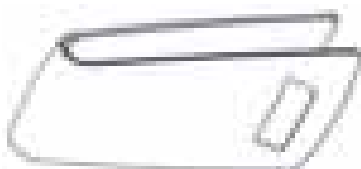

1.4



1.5



1.6

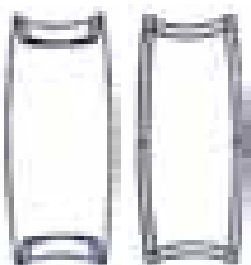

1.7

1.8



1.9



1.10

- (11) **13289**  
(21) 3-2008-00694 (28) 01  
(54) BÚT PHẪU (51) **19-02**  
(22) 21.05.2008 (43) 25.08.2008  
(71) SDI CORPORATION (TW)  
No. 260, Sec. 2, Chang Nan Rd., Chang Hua, Taiwan  
(72) Hsien-Cheng LIN (TW)  
(74) Công ty TNHH Trường Xuân (AGELESS CO.,LTD.)  
(55)



1.1

1.2



1.2

1.4



1.5

1.6



1.7

1.8

- (11) **13290**  
(21) 3-2008-00701 (28) 01  
(54) ĐỒNG HỒ ĐÚNG (51) **10-01**  
(22) 26.05.2008 (43) 25.08.2008  
(71) CÔNG TY TNHH SẢN XUẤT THƯƠNG MẠI ĐẠI HÙNG (VN)  
372/15/11A Cách Mạng Tháng 8, phường 10, quận 3, TP. Hồ Chí Minh  
(72) Nguyễn Thị Minh Hoàng (VN)  
(74) DNTN Dịch vụ thương mại và sở hữu công nghiệp Song Ngọc (I.P.T.S.)  
(55)



1.1

1.2

1.3

1.4



1.5

1.6

- (11) **13291**  
(21) 3-2008-00702 (28) 01  
(54) ĐIỆN THOẠI ĐỂ BÀN (51) **14-03**  
(22) 26.05.2008 (43) 25.08.2008  
(71) CÔNG TY TNHH THƯƠNG MẠI VIỄN THÔNG THẾ KỶ (VN)  
88 Trần Trọng Cung, phường Tân Thuận Đông, quận 7, TP. Hồ Chí Minh  
(72) Nguyễn Thị Bé Mười (VN)  
(74) DNTN Dịch vụ thương mại và sở hữu công nghiệp Song Ngọc (I.P.T.S.)  
(55)



1.1



1.2

1.3

1.4



1.5

1.6



1.7

1.8

- (11) **13292**  
(21) 3-2008-00703  
(54) NHÃN SẢN PHẨM  
(22) 26.05.2008  
(71) ĐỒ DANH TUÂN (VN)  
Đội 4 Đồng Tâm, xã Minh Khai, huyện Hoài Đức, tỉnh Hà Tây  
(72) Đồ Danh Tuân (VN)  
(74) Công ty TNHH Sở hữu trí tuệ Gia Việt (GIAVIET CO., LTD.)  
(55)
- (28) 01  
(51) **19-08**  
(43) 25.08.2008



- (11) **13293**  
(21) 3-2008-00704 (28) 01  
(54) TỦ NHỰA (51) **06-04**  
(22) 26.05.2008 (43) 25.08.2008  
(71) CÔNG TY TRÁCH NHIỆM HỮU HẠN NHỰA DUY TÂN (VN)  
298 Hồ Học Lãm, phường An Lạc, quận Bình Tân, TP. Hồ Chí Minh  
(72) Trần Phước An (VN)  
(74) Công ty TNHH Sở hữu trí tuệ Thảo Thọ Quyến (INVENCO)  
(55)

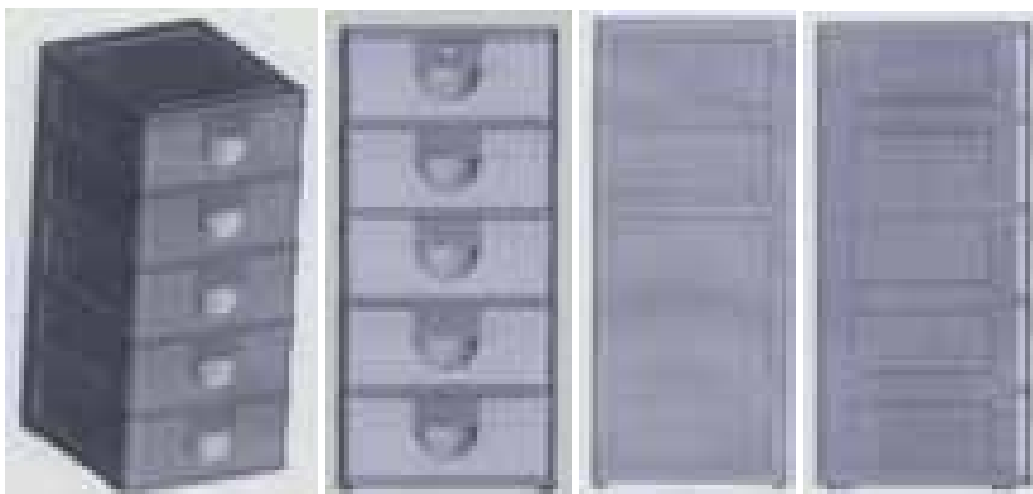

1.1

1.2

1.3

1.4

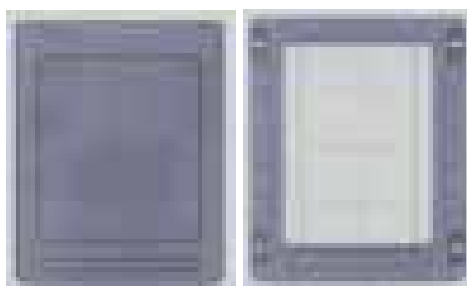

1.5

1.6



- (11) **13294**  
(21) 3-2008-00713  
(54) CHAI  
(22) 27.05.2008  
(71) CÔNG TY CỔ PHẦN SONG HOA (VN)  
10/4 đường số 3, khu phố 4, phường Bình An, quận 2, TP. Hồ Chí Minh  
(72) Nguyễn Thị Đức Hạnh (VN)  
(74) Văn phòng luật sư Phạm và Liên danh (PHAM & ASSOCIATES)  
(55)
- (28) 01  
(51) **09-01**  
(43) 25.08.2008

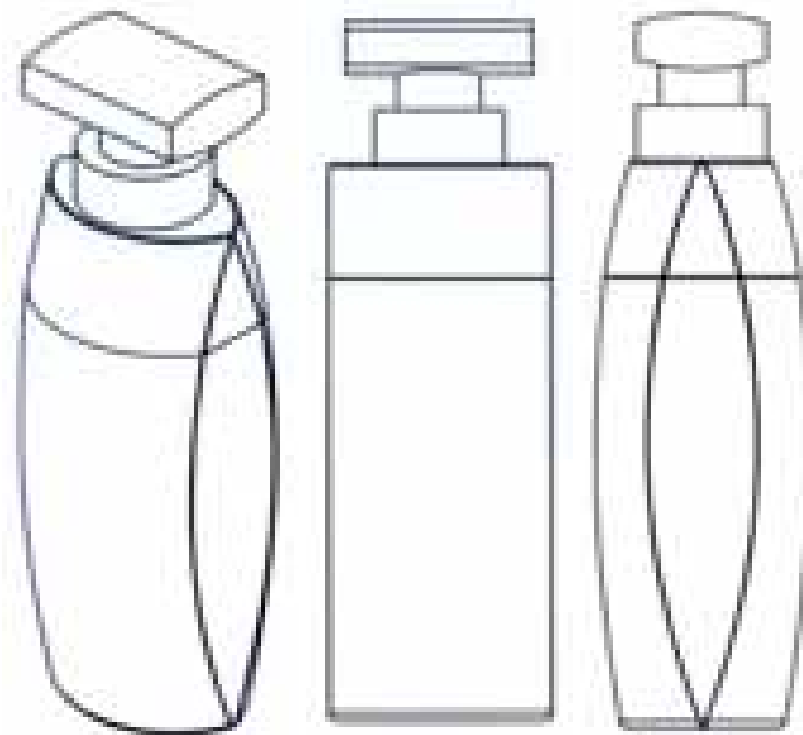

1.1

1.2

1.3

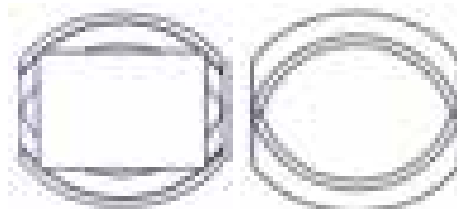

1.4

1.5

- (11) **13295**  
(21) 3-2008-00716 (28) 01  
(54) TÁCH (51) **07-01**  
(22) 28.05.2008 (43) 25.08.2008  
(30) 4005419 28.11.2007 GB  
(71) UNILEVER N.V. (NL)  
Weena 455, 3013 AL Rotterdam, Netherlands  
(72) Neil HIRST (GB), Edward Arthur Charles MITCHELL (GB)  
(74) Công ty TNHH Trần Hữu Nam và Đồng sự (TRAN H.N & ASS.)  
(55)



1.1



1.2



1.3

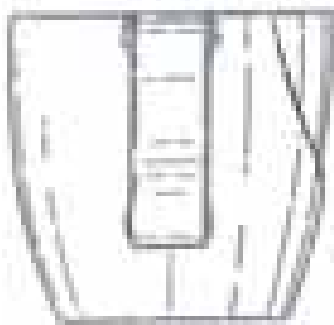

1.4

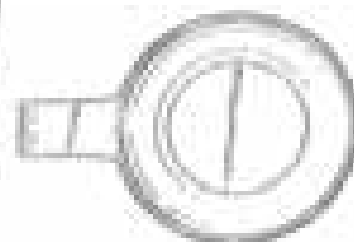

1.5

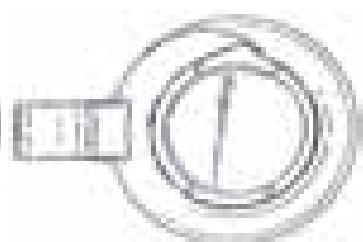

1.6

- (11) **13296**  
(21) 3-2008-00717 (28) 01  
(54) MÁY HÀN KIM LOẠI (51) **15-09**  
(22) 29.05.2008 (43) 25.08.2008  
(71) CÔNG TY TNHH THƯƠNG MẠI NAM HÀN (VN)  
77 Bùi Hữu Nghĩa, phường 5, quận 5, TP. Hồ Chí Minh  
(72) Hồ Kim Thanh (VN)  
(74) Trung tâm tư vấn phát triển Thương hiệu và Chất lượng (NATUSI)  
(55)



1.1

1.2

1.3

1.4

1.5

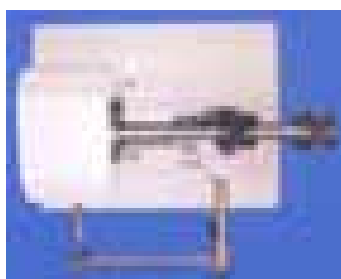

1.6

- (11) **13297**  
(21) 3-2008-00718 (28) 01  
(54) MÁY DỒN DÂY KIM LOẠI (51) **15-99**  
(22) 29.05.2008 (43) 25.08.2008  
(71) CÔNG TY TNHH THƯƠNG MẠI NAM HÀN (VN)  
77 Bùi Hứa Nghĩa, phường 5, quận 5, TP. Hồ Chí Minh  
(72) Hồ Kim Thanh (VN)  
(74) Trung tâm tư vấn phát triển Thương hiệu và Chất lượng (NATUSI)  
(55)



1.1

1.2

1.3

1.4



1.5

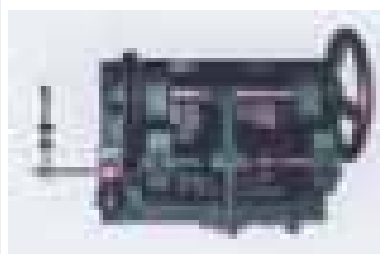

1.6

- (11) **13298**  
(21) 3-2008-00719 (28) 01  
(54) MÁY ĐÁNH BÓNG MẶT KIM (51) **15-09**  
LOẠI  
(22) 29.05.2008 (43) 25.08.2008  
(71) CÔNG TY TNHH THƯƠNG MẠI NAM HÀN (VN)  
77 Bùi Hữu Nghĩa, phường 5, quận 5, TP. Hồ Chí Minh  
(72) Hồ Kim Thanh (VN)  
(74) Trung tâm tư vấn phát triển Thương hiệu và Chất lượng (NATUSI)  
(55)

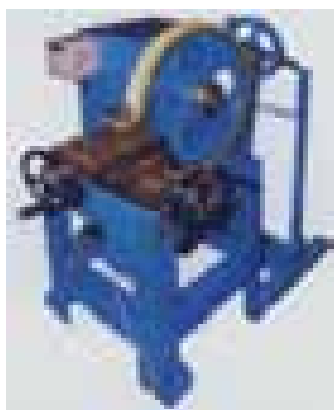

1.1



1.2

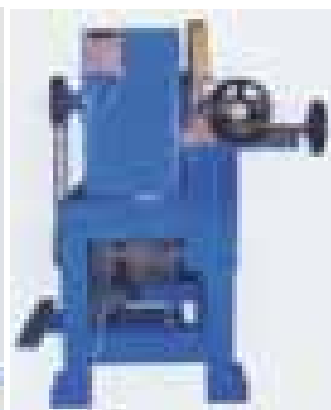

1.3



1.4



1.5



1.6

- (11) **13299**  
(21) 3-2008-00720 (28) 01  
(54) MÁY ĐAN DÂY KIM LOẠI (51) **15-09**  
(22) 29.05.2008 (43) 25.08.2008  
(71) CÔNG TY TNHH THƯƠNG MẠI NAM HÀN (VN)  
77 Bùi Hứa Nghĩa, phường 5, quận 5, TP. Hồ Chí Minh  
(72) Hồ Kim Thanh (VN)  
(74) Trung tâm tư vấn phát triển Thương hiệu và Chất lượng (NATUSI)  
(55)



1.1

1.2

1.3

1.4



1.5

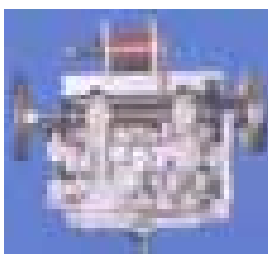

1.6

- (11) **13300**  
(21) 3-2008-00721 (28) 01  
(54) CHAI NHỰA (51) **09-01**  
(22) 29.05.2008 (43) 25.08.2008  
(71) CÔNG TY CỔ PHẦN CÔNG NGHIỆP - THƯƠNG MẠI MA SAN (VN)  
Lô III-12- nhóm công nghiệp III, khu công nghiệp Tân Bình, phường Tây Thạnh, quận Tân Phú, TP. Hồ Chí Minh  
(72) Nguyễn Đăng Quang (VN)  
(74) Công ty TNHH Sở hữu trí tuệ Thảo Thọ Quyến (INVENCO)  
(55)



1.1

1.2

1.3

1.4

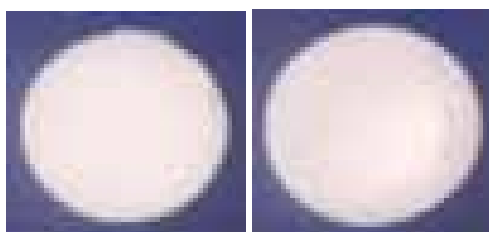

1.5

1.6

- (11) **13301**  
(21) 3-2008-00723 (28) 01  
(54) MÁY TÍNH CÁ NHÂN CÓ KÍCH (51) **14-02**  
THƯỚC CUỐN SỔ GHI CHÉP  
(22) 29.05.2008 (43) 25.08.2008  
(30) 30-2008-0010606 12.03.2008 KR  
(71) TRIGEM COMPUTER, INC. (KR)  
of 1125-1, Singil-dong, Danwon-gu, Ansan-si, Gyeonggi-do, Korea  
(72) Soo-hyun Han (KR)  
(74) Công ty TNHH Tư vấn BIZCONSULT (BIZCONSULT CO., LTD.)  
(55)



1.1

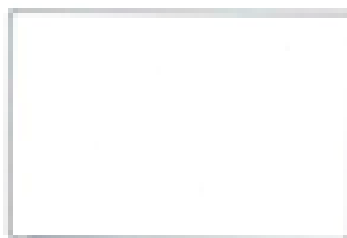

1.2

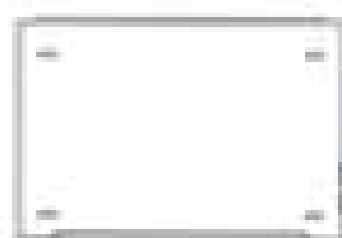

1.3

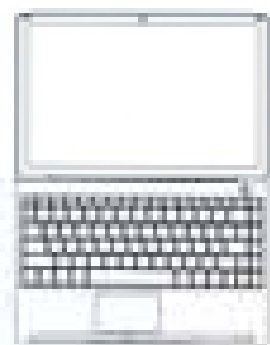

1.4



1.5



1.6



1.7



1.8



- (11) **13302**  
(21) 3-2008-00724 (28) 01  
(54) MÀN HÌNH MÁY TÍNH (51) **14-02**  
(22) 29.05.2008 (43) 25.08.2008  
(30) 30-2008-0010405 11.03.2008 KR  
(71) TRIGEM COMPUTER, INC. (KR)  
of 1125-1, Singil-dong, Danwon-gu, Ansan-si, Gyeonggi-do, Korea  
(72) Hyun-Saeng Ahn (KR)  
(74) Công ty TNHH Tư vấn BIZCONSULT (BIZCONSULT CO., LTD.)  
(55)



1.1

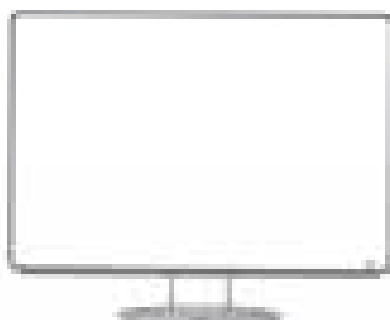

1.2

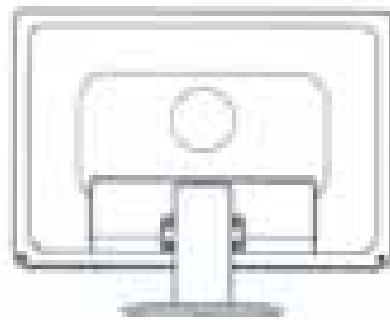

1.3



1.4



1.6

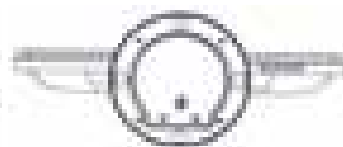

1.7

- (11) **13303**  
(21) 3-2008-00725 (28) 01  
(54) MÀN HÌNH MÁY TÍNH (51) **14-02**  
(22) 29.05.2008 (43) 25.08.2008  
(30) 30-2008-0011709 18.03.2008 KR  
(71) TRIGEM COMPUTER, INC. (KR)  
of 1125-1, Singil-dong, Danwon-gu, Ansan-si, Gyeonggi-do, Korea  
(72) Hyun-Saeng Ahn (KR)  
(74) Công ty TNHH Tư vấn BIZCONSULT (BIZCONSULT CO., LTD.)  
(55)

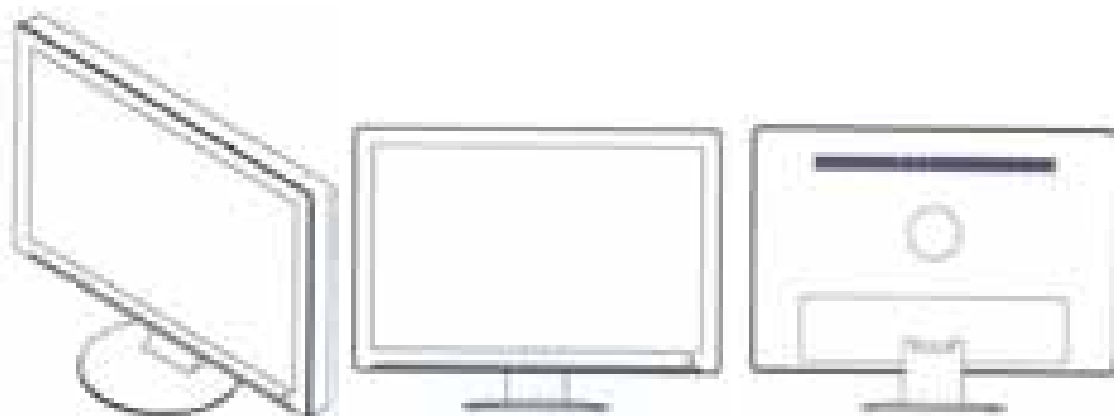

1.1

1.2

1.3



1.4

1.5

1.6

1.7

- (11) **13304**  
(21) 3-2008-00728 (28) 03  
(54) BAO GÓI KẸO (51) **09-05**  
(22) 30.05.2008 (43) 25.08.2008  
(71) TẠ TƯỜNG TRƯỜNG (VN)  
Xóm Đoàn Kết, xã La Phù, huyện Hoài Đức, tỉnh Hà Tây  
(72) Tạ Tường Trường (VN)  
(74) Công ty cổ phần Sở hữu trí tuệ BROSS và Cộng sự (BROSS & PARTNERS., JSC)  
(55)



1.1



1.2



2.1



2.2



3.1



3.2

- (11) **13305**  
(21) 3-2008-00729 (28) 01  
(54) LOA XE Ô TÔ (51) **14-01**  
(22) 30.05.2008 (43) 25.08.2008  
(30) 200830008595.0 06.03.2008 CN  
(71) SONY CORPORATION (JP)  
1-7-1 Konan, Minato-ku, Tokyo, Japan  
(72) Daisuke Kurihara (JP)  
(74) Công ty TNHH một thành viên Sở hữu trí tuệ VCCI (VCCI-IP CO.,LTD)  
(55)



1.1

1.2

1.3



1.4

1.5

1.6

1.7

- (11) **13306**  
(21) 3-2008-00730 (28) 01  
(54) LOA XE Ô TÔ (51) **14-01**  
(22) 30.05.2008 (43) 25.08.2008  
(30) 200830008596.5 06.03.2008 CN  
(71) SONY CORPORATION (JP)  
1-7-1 Konan, Minato-ku, Tokyo, Japan  
(72) Daisuke Kurihara (JP)  
(74) Công ty TNHH một thành viên Sở hữu trí tuệ VCCI (VCCI-IP CO.,LTD)  
(55)



1.1



1.2



1.3

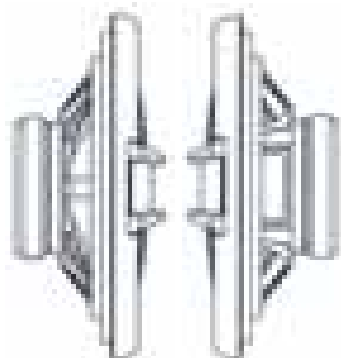

1.4



1.5



1.6



1.7

- (11) **13307**  
(21) 3-2008-00731 (28) 01  
(54) LOA XE Ô TÔ (51) **14-01**  
(22) 30.05.2008 (43) 25.08.2008  
(30) 200830008597.X 06.03.2008 CN  
(71) SONY CORPORATION (JP)  
1-7-1 Konan, Minato-ku, Tokyo, Japan  
(72) Daisuke Kurihara (JP)  
(74) Công ty TNHH một thành viên Sở hữu trí tuệ VCCI (VCCI-IP CO.,LTD)  
(55)

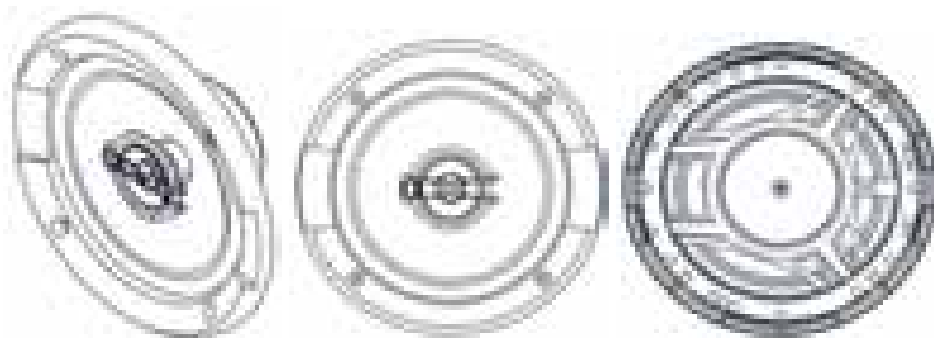

1.1

1.2

1.3



1.4

1.5

1.6

1.7

- (11) **13308**  
(21) 3-2008-00732 (28) 01  
(54) LOA XE Ô TÔ (51) **14-01**  
(22) 30.05.2008 (43) 25.08.2008  
(30) 200830008594.6 06.03.2008 CN  
(71) SONY CORPORATION (JP)  
1-7-1 Konan, Minato-ku, Tokyo, Japan  
(72) Daisuke Kurihara (JP)  
(74) Công ty TNHH một thành viên Sở hữu trí tuệ VCCI (VCCI-IP CO.,LTD)  
(55)



1.1



1.2



1.3

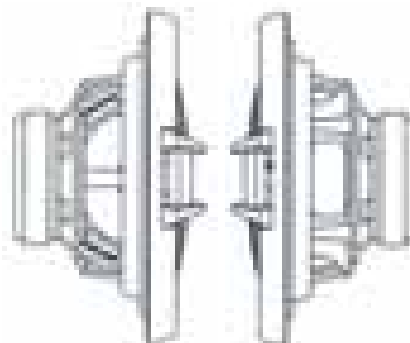

1.4

1.5



1.6



- (11) **13309**  
(21) 3-2008-00733 (28) 01  
(54) HỘP ĐUNG MỰC IN (51) **18-02**  
(22) 30.05.2008 (43) 25.08.2008  
(30) 2007-033060 30.11.2007 JP  
(71) BROTHER INDUSTRIES, LTD. (JP)  
15-1 Naeshiro-cho, Mizuho-ku, Nagoya-shi, Aichi-ken, Japan  
(72) Shingo HATTORI (JP)  
(74) Công ty TNHH Ban Ca (BANCA)  
(55)

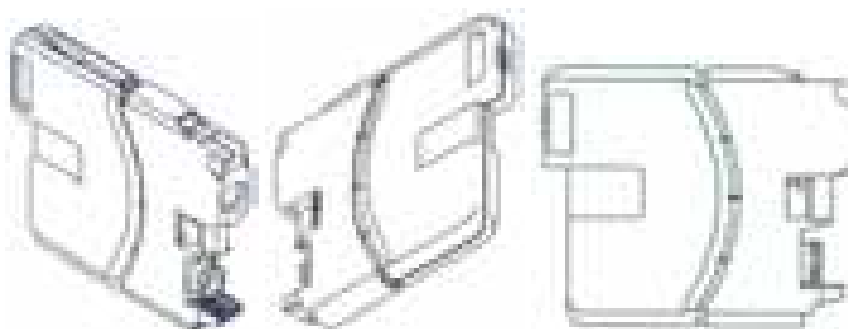

1.1

1.2

1.3

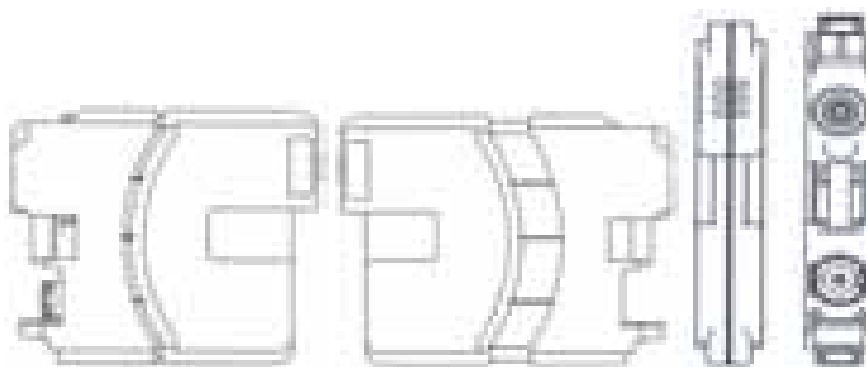

1.4

1.5

1.6

1.7



1.8

1.9

- (11) **13310**  
(21) 3-2008-00737 (28) 01  
(54) BAO GÓI TĨ GIẤY (51) **09-05**  
(22) 30.05.2008 (43) 25.08.2008  
(71) DOANH NGHIỆP TƯ NHÂN HIẾU HUYỀN (VN)  
171 I Minh Khai, thành phố Hà Nội  
(72) Nguyễn Văn Chính (VN)  
(74) Công ty Tư vấn đầu tư và chuyển giao công nghệ (INVESTCONSULT)  
(55)



1.1



1.2

- (11) **13311**  
(21) 3-2008-00738 (28) 01  
(54) GIƯỜNG (51) **06-02**  
(22) 30.05.2008 (43) 25.08.2008  
(71) DOANH NGHIỆP TƯ NHÂN DUY PHƯƠNG (VN)  
105C Hồ Học Lãm, khu phố 1, phường An Lạc, quận Bình Tân, TP. Hồ Chí Minh  
(72) Nguyễn Văn Hương (VN)  
(74) DNTN Dịch vụ thương mại và sở hữu công nghiệp Song Ngọc (I.P.T.S.)  
(55)

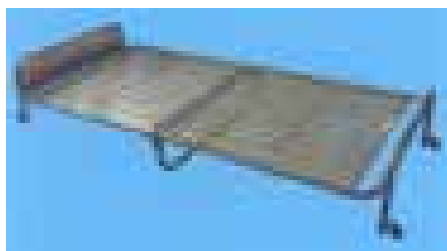

1.1

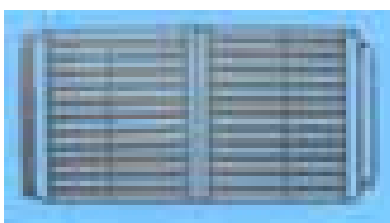

1.2

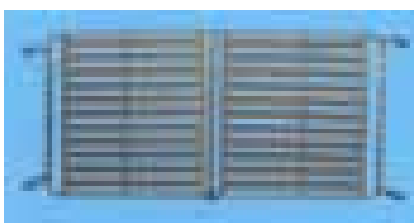

1.3



1.4

1.5

1.6

- (11) **13312**  
(21) 3-2008-00739 (28) 01  
(54) XE Ô TÔ (51) **12-08**  
(22) 02.06.2008 (43) 25.08.2008  
(30) 29/290,596 19.12.2007 US  
(71) HONDA MOTOR CO., LTD. (JP)  
1-1, Minami-Aoyama 2-chome, Minato-ku, Tokyo, Japan  
(72) Damon A. Schell (US)  
(74) Văn phòng luật sư Phạm và Liên danh (PHAM & ASSOCIATES)  
(55)



1.1



1.2

1.3



1.4

1.5

1.6

- (11) **13313**  
(21) 3-2008-00740 (28) 01  
(54) CỤM ĐÈN PHÍA TRƯỚC XE Ô TÔ (51) **26-06**  
(22) 02.06.2008 (43) 25.08.2008  
(30) 29/290598 19.12.2007 US  
(71) HONDA MOTOR CO., LTD. (JP)  
1-1, Minami-Aoyama 2-chome, Minato-ku, Tokyo, Japan  
(72) Randall Smock (US), Gou Koyama (JP)  
(74) Văn phòng luật sư Phạm và Liên danh (PHAM & ASSOCIATES)  
(55)



1.1

1.2

1.3

1.4



1.5

1.6

1.7



1.8

1.9

- (11) **13314**  
(21) 3-2008-00741 (28) 01  
(54) CỤM ĐÈN PHÍA SAU XE Ô TÔ (51) **26-06**  
(22) 02.06.2008 (43) 25.08.2008  
(30) 29/290,593 19.12.2007 US  
(71) HONDA MOTOR CO., LTD. (JP)  
1-1, Minami-Aoyama 2-chome, Minato-ku, Tokyo, Japan  
(72) Randall Smock (US), Gou Koyama (JP)  
(74) Văn phòng luật sư Phạm và Liên danh (PHAM & ASSOCIATES)  
(55)



1.1

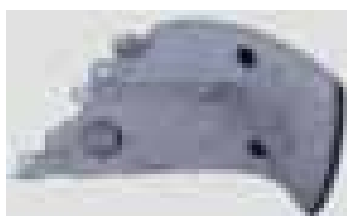

1.2



1.3



1.4

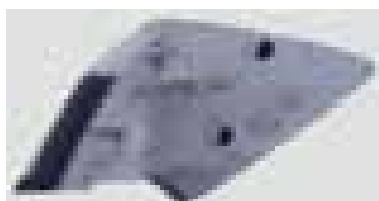

1.5



1.6



1.7



1.8



1.9

- (11) **13315**  
(21) 3-2008-00742 (28) 01  
(54) XE MÔ TÔ (51) **12-11**  
(22) 02.06.2008 (43) 25.08.2008  
(71) SANYANG INDUSTRY CO., LTD. (TW)  
No. 184, Keng Tzu Kou, Shang Keng Village, Hsin Fong Shiang, Hsinchu, County 304,  
Taiwan  
(72) Jun-Sheng CHU (TW)  
(74) Công ty TNHH Trường Xuân (AGELESS CO.,LTD.)  
(55)



1.1

1.2

1.3



1.4

1.5

1.6



1.7

1.8

1.9

- (11) **13316**  
(21) 3-2008-00743 (28) 01  
(54) MÁY TÍNH (51) **14-02**  
(22) 03.06.2008 (43) 25.08.2008  
(30) 30-2008-0010408 11.03.2008 KR  
(71) TRIGEM COMPUTER, INC. (KR)  
of 1125-1, Singil-dong, Danwon-gu, Ansan-si, Gyeonggi-do, Korea  
(72) Jong-Deok Kim (KR)  
(74) Công ty TNHH Tư vấn BIZCONSULT (BIZCONSULT CO., LTD.)  
(55)

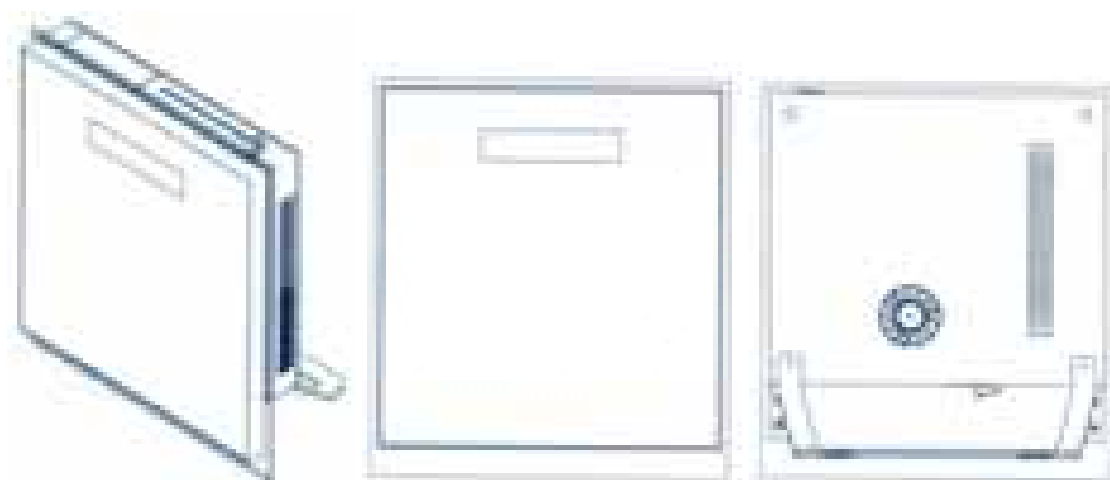

1.1

1.2

1.3

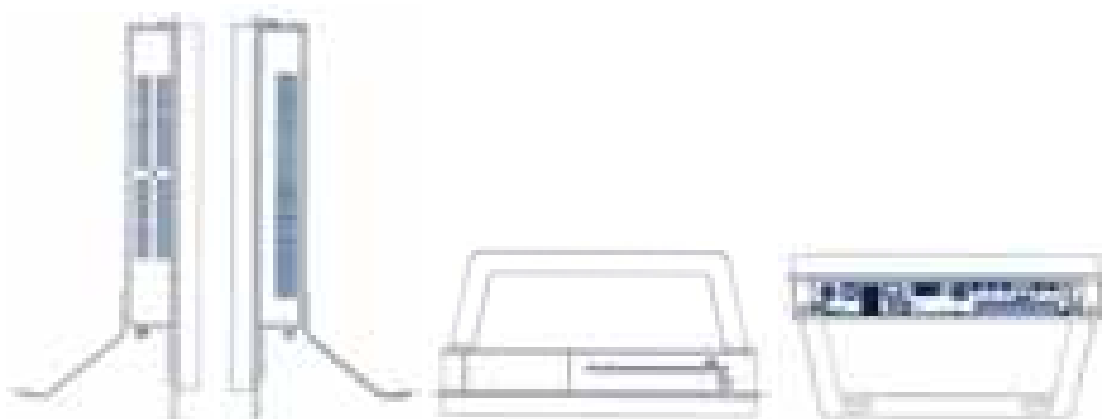

1.4

1.5

1.6

1.7



- (11) **13317**  
(21) 3-2008-00744 (28) 01  
(54) BÃY CHUỘT (51) **22-06**  
(22) 03.06.2008 (43) 25.08.2008  
(71) CÔNG TY TNHH SẢN XUẤT THƯƠNG MẠI GIÀY ĐỨC MINH (VN)  
339 Tân Hòa Đông, phường Bình Trị Đông, quận Bình Tân, TP. Hồ Chí Minh  
(72) Hoàng Đức Vũ (VN)  
(74) Công ty TNHH Sở hữu trí tuệ WINCO (WINCO CO., LTD.)  
(55)



1.1



1.2

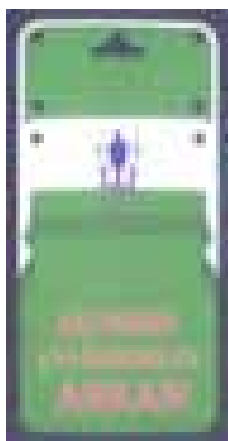

1.3



1.4

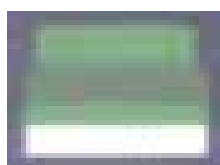

1.5

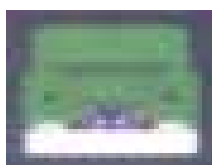

1.6

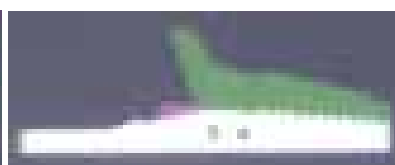

1.7

- (11) **13318**  
(21) 3-2008-00745 (28) 01  
(54) TAY CẦM CỦA NẮP VUNG (51) **07-02**  
(22) 03.06.2008 (43) 25.08.2008  
(30) 30-2007-0049996 03.12.2007 KR  
(71) 1. CHEFEL CO., LTD. (KR)  
Samgye-Dong, Gimhae-Si, Gyeongsangnam-Do 621-070, Republic of Korea  
2. DONGSEO UNIVERSITY - INDUSTRY COLLABORATION FOUNDATION (KR)  
San 69-1, Churye-2Dong, Sasang-Gu, Busan 617-716, Republic of Korea  
(72) LEE, HYUN SAM (KR), KANG, Bum Kyu (KR)  
(74) Công ty TNHH Sở hữu trí tuệ Đại Diện (IPACO.,LTD.)  
(55)



1.1



1.2

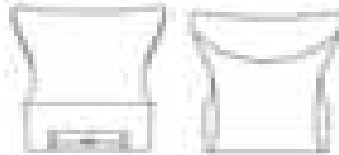

1.3

1.4



1.5



1.6



1.7

- (11) **13319**  
(21) 3-2008-00746 (28) 01  
(54) HỘP CAO DÁN (51) **09-03**  
(22) 04.06.2008 (43) 25.08.2008  
(71) CÔNG TY TNHH DƯỢC PHẨM THIÊN ÂN (VN)  
37 Võ Văn Dũng, quận Đống Đa, thành phố Hà Nội  
(72) Nguyễn Thị Kim Phượng (VN)  
(74) Công ty TNHH Sở hữu trí tuệ WINCO (WINCO CO., LTD.)  
(55)

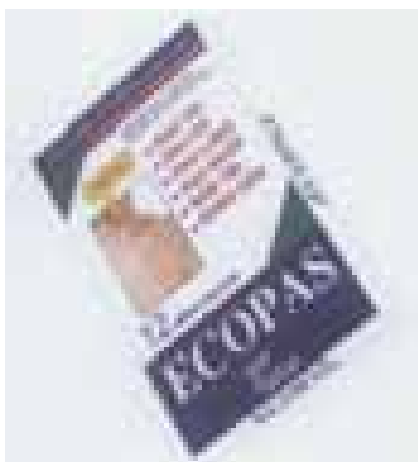

1.1

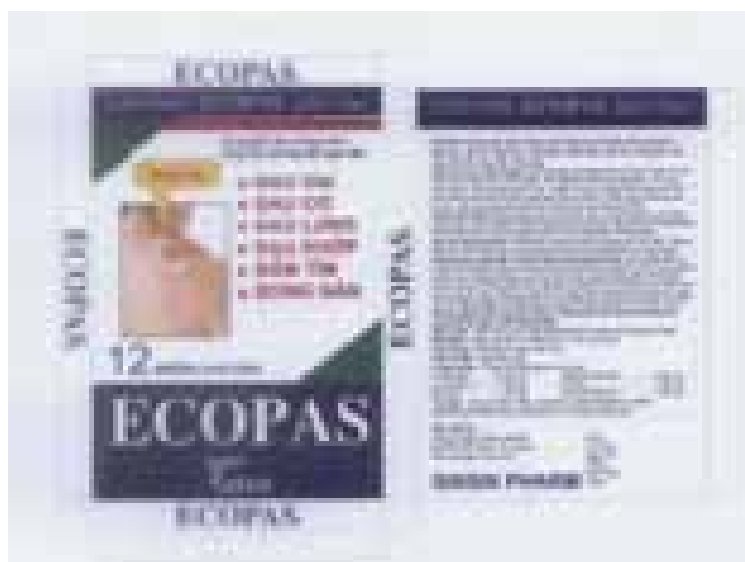

1.2

- (11) **13320**  
(21) 3-2008-00747 (28) 01  
(54) CHAI (51) **09-01**  
(22) 05.06.2008 (43) 25.08.2008  
(71) DOANH NGHIỆP TƯ NHÂN SẢN XUẤT THƯƠNG MẠI TRUNG VỊ (VN)  
A4/2A hương lộ 4, ấp 1, xã Tân Kiên, huyện Bình Chánh, tp. Hồ Chí Minh  
(72) Trần Thiện Hữu (VN)  
(74) Trung tâm tư vấn phát triển Thương hiệu và Chất lượng (NATUSI)  
(55)



1.1

1.2

1.3

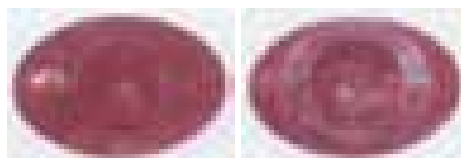

1.4

1.5

- (11) **13321**  
(21) 3-2008-00748 (28) 01  
(54) CHAI (51) **09-01**  
(22) 05.06.2008 (43) 25.08.2008  
(71) CÔNG TY TNHH SẢN XUẤT THƯƠNG MẠI NHÂN LỘC (VN)  
50 Ký Hòa, phường 11, quận 5, TP. Hồ Chí Minh  
(72) Lê Hữu Lộc (VN)  
(74) Trung tâm tư vấn phát triển Thương hiệu và Chất lượng (NATUSI)  
(55)



1.1

1.2

1.3

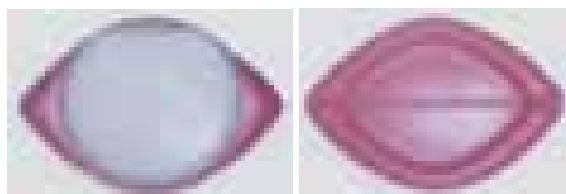

1.4

1.5

- (11) **13322**  
(21) 3-2008-00749 (28) 01  
(54) NHÃN SẢN PHẨM NƯỚC UỐNG (51) **19-08**  
(22) 05.06.2008 (43) 25.08.2008  
(71) CÔNG TY CỔ PHẦN ĐỒ UỐNG HÀ NỘI ADP (VN)  
Phòng 102 B3, tập thể Thanh Xuân Bắc, phường Thanh Xuân Bắc, quận Thanh Xuân,  
thành phố Hà Nội  
(72) Đào Ngọc Anh (VN), Ngô Thị Thanh Hải (VN)  
(55)



- (11) **13323**  
(21) 3-2008-00750 (28) 02  
(54) BAO GÓI (51) **09-05**  
(22) 05.06.2008 (43) 25.08.2008  
(71) CÔNG TY CỔ PHẦN KỸ NGHỆ THỰC PHẨM VIỆT NAM (VN)  
913 Trường Chinh, phường Tây Thạnh, quận Tân Phú, TP. Hồ Chí Minh  
(72) Nguyễn Văn Bên (VN)  
(74) Văn phòng luật sư Phạm và Liên danh (PHAM & ASSOCIATES)  
(55)



1.1



1.2



2.1



2.2



- (11) **13324**  
(21) 3-2008-00753 (28) 01  
(54) BAO GÓI (51) **09-05**  
(22) 05.06.2008 (43) 25.08.2008  
(71) Orion Corporation (KR)  
30-10, Munbae-Dong, Yongsan-Ku, Seoul, Republic of Korea  
(72) Hwa-Kyung LEE (KR)  
(74) Công ty TNHH Sở hữu trí tuệ Thảo Thọ Quyến (INVENCO)  
(55)



1.1

1.2

1.3

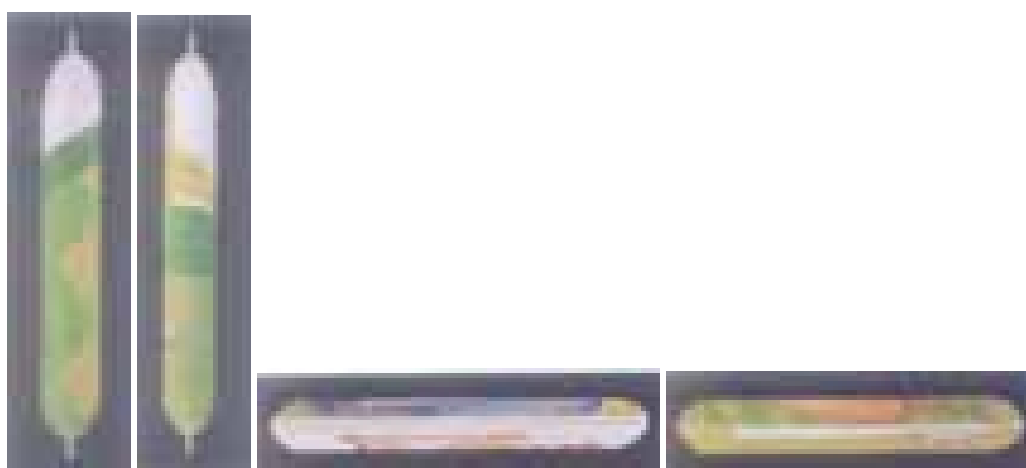

1.4

1.5

1.6

1.7

- (11) **13325**  
(21) 3-2008-00754 (28) 01  
(54) BAO GÓI (51) **09-05**  
(22) 05.06.2008 (43) 25.08.2008  
(71) ORION CORPORATION (KR)  
30-10, Munbae-Dong, Yongsan-Ku, Seoul, Republic of Korea  
(72) Hwa-Kyung LEE (KR)  
(74) Công ty TNHH Sở hữu trí tuệ Thảo Thọ Quyển (INVENCO)  
(55)



1.1

1.2

1.3



1.4

1.5

1.6

1.7

- (11) **13326**  
(21) 3-2008-00755 (28) 01  
(54) BAO GÓI (51) **09-05**  
(22) 05.06.2008 (43) 25.08.2008  
(71) ORION CORPORATION (KR)  
30-10, Munbae-Dong, Yongsan-Ku, Seoul, Republic of Korea  
(72) Hwa-Kyung LEE (KR)  
(74) Công ty TNHH Sở hữu trí tuệ Thảo Thọ Quyến (INVENCO)  
(55)



1.1

1.2

1.3

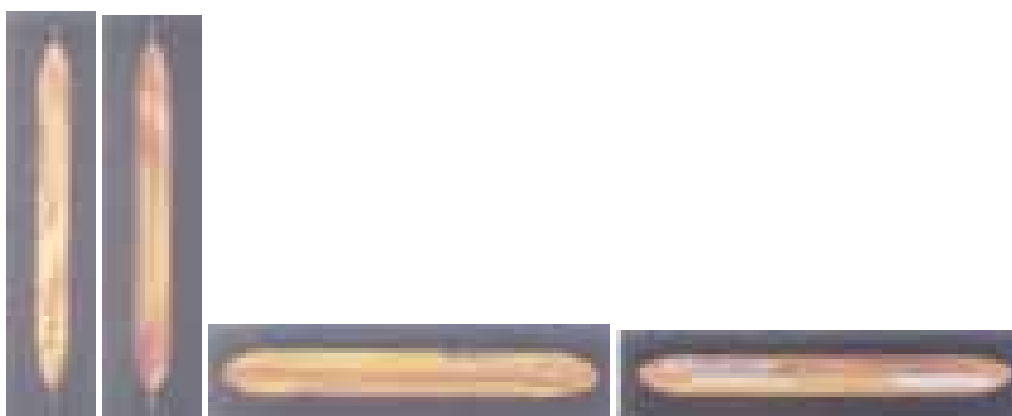

1.4

1.5

1.6

1.7

- (11) **13327**  
(21) 3-2008-00756  
(54) BAO GÓI  
(22) 05.06.2008  
(71) ORION CORPORATION (KR)  
30-10, Munbae-Dong, Yongsan-Ku, Seoul, Republic of Korea  
(72) Hwa-Kyung LEE (KR)  
(74) Công ty TNHH Sở hữu trí tuệ Thảo Thọ Quyến (INVENCO)  
(55)
- (28) 01  
(51) **09-05**  
(43) 25.08.2008



1.1

1.2

1.3

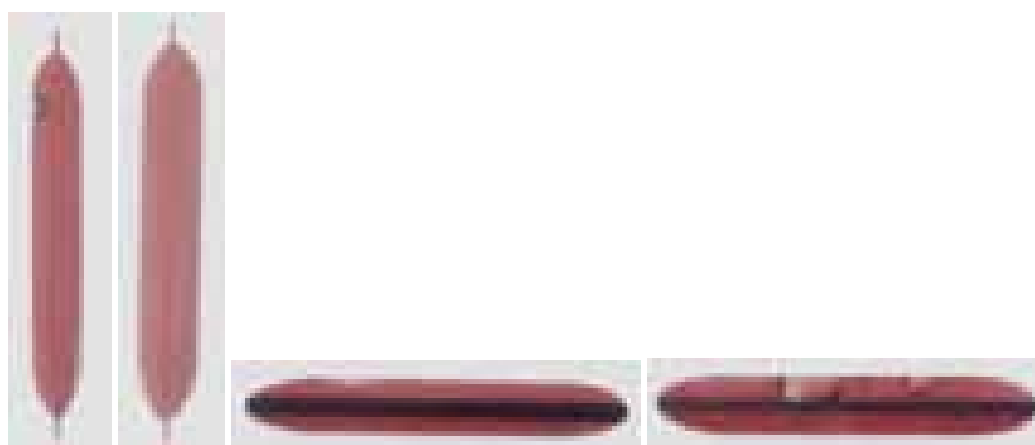

1.4

1.5

1.6

1.7

- (11) **13328**  
(21) 3-2008-00757 (28) 01  
(54) BAO GÓI (51) **09-05**  
(22) 05.06.2008 (43) 25.08.2008  
(71) ORION CORPORATION (KR)  
30-10, Munbae-Dong, Yongsan-Ku, Seoul, Republic of Korea  
(72) Hwa-Kyung LEE (KR)  
(74) Công ty TNHH Sở hữu trí tuệ Thảo Thọ Quyển (INVENCO)  
(55)



1.1

1.2

1.3



1.4

1.5

1.6

1.7

- (11) **13329**  
(21) 3-2008-00758 (28) 01  
(54) BAO GÓI (51) **09-05**  
(22) 05.06.2008 (43) 25.08.2008  
(71) ORION CORPORATION (KR)  
30-10, Munbae-Dong, Yongsan-Ku, Seoul, Republic of Korea  
(72) Hwa-Kyung LEE (KR)  
(74) Công ty TNHH Sở hữu trí tuệ Thảo Thọ Quyển (INVENCO)  
(55)



1.1

1.2

1.3

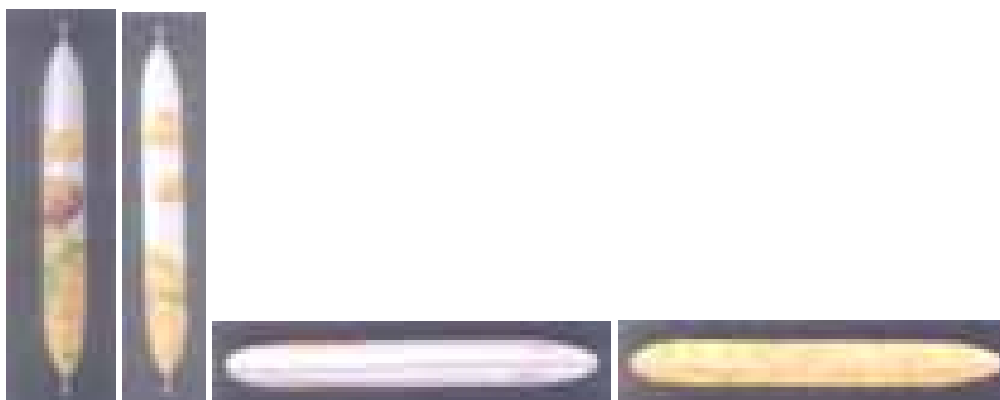

1.4

1.5

1.6

1.7

- (11) **13330**  
(21) 3-2008-00759 (28) 01  
(54) BAO GÓI (51) **09-05**  
(22) 05.06.2008 (43) 25.08.2008  
(71) ORION CORPORATION (KR)  
30-10, Munbae-Dong, Yongsan-Ku, Seoul, Republic of Korea  
(72) Hwa-Kyung LEE (KR)  
(74) Công ty TNHH Sở hữu trí tuệ Thảo Thọ Quyển (INVENCO)  
(55)



1.1

1.2

1.3

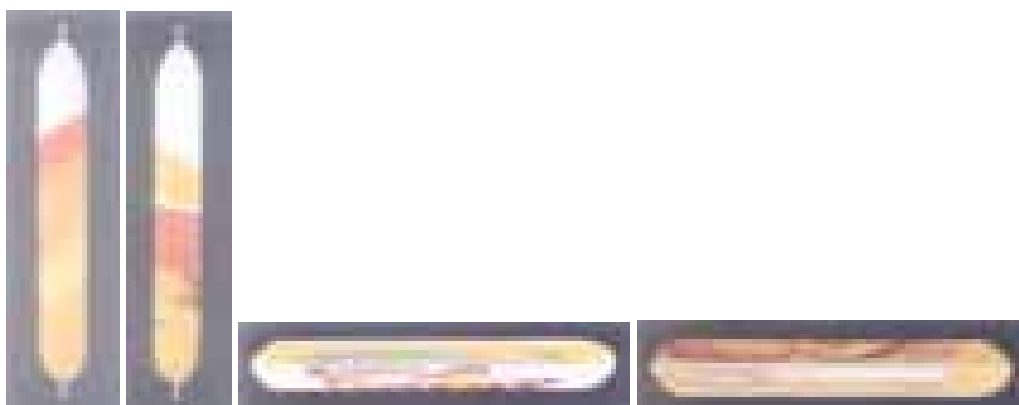

1.4

1.5

1.6

1.7

- (11) **13331**  
(21) 3-2008-00760 (28) 01  
(54) BAO GÓI (51) **09-05**  
(22) 05.06.2008 (43) 25.08.2008  
(71) ORION CORPORATION (KR)  
30-10, Munbae-Dong, Yongsan-Ku, Seoul, Republic of Korea  
(72) Hwa-Kyung LEE (KR)  
(74) Công ty TNHH Sở hữu trí tuệ Thảo Thọ Quyển (INVENCO)  
(55)



1.1

1.2

1.3



1.4

1.5

1.6

1.7



- (11) **13332**  
(21) 3-2008-00761 (28) 01  
(54) BAO BÌ (51) **09-05**  
(22) 06.06.2008 (43) 25.08.2008  
(71) CÔNG TY TRÁCH NHIỆM HỮU HẠN CHẾ BIẾN THỰC PHẨM ĐỒNG QUÊ VIỆT (VN)  
70/4A Lâm Văn Bền, phường Tân Kiểng, quận 7, TP. Hồ Chí Minh  
(72) Lê Văn Chân (VN)  
(74) Công ty TNHH Sở hữu trí tuệ Thảo Thọ Quyến (INVENCO)  
(55)



1.1



1.2

- (11) **13333**  
(21) 3-2008-00762 (28) 01  
(54) **VẬT DỤNG KHỬ MÙI KHÔNG KHÍ** (51) **28-99**  
(22) 06.06.2008 (43) 25.08.2008  
(30) 000896758-0001 12.03.2008 EM  
(71) SARA LEE HOUSEHOLD AND BODY CARE NEDERLAND B.V. (NL)  
Vleutensevaart 35, 3532 AD Utrecht, The Netherlands  
(72) Bjorn Weggelaar (NL)  
(74) Công ty TNHH một thành viên Sở hữu trí tuệ VCCI (VCCI-IP CO.,LTD)  
(55)

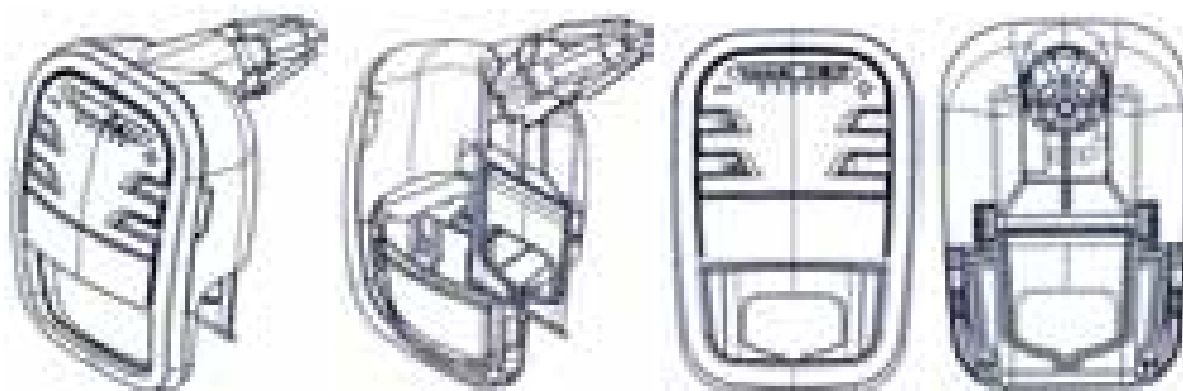

1.1

1.2

1.3

1.4

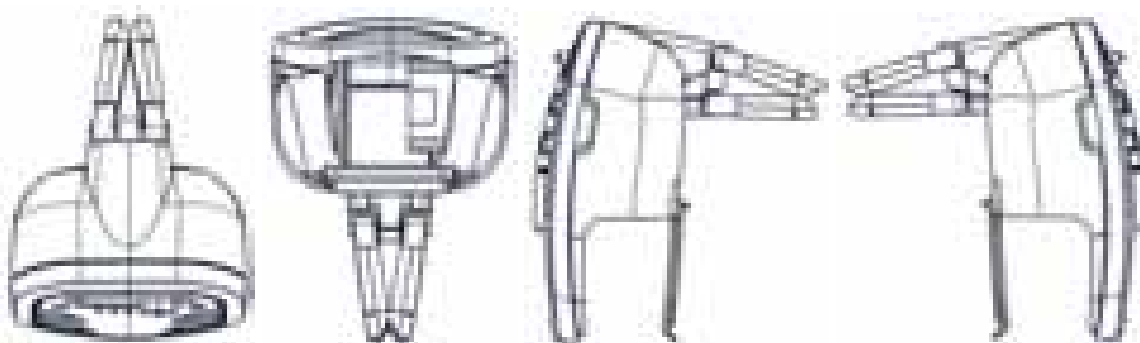

1.5

1.6

1.7

1.8

- (11) **13334**  
(21) 3-2008-00764 (28) 01  
(54) BAO BÌ (51) **09-05**  
(22) 09.06.2008 (43) 25.08.2008  
(71) CÔNG TY CỔ PHẦN MAY THIÊN HÀ (VN)  
424 Phạm Văn Bạch, phường 15, quận Tân Bình, TP. Hồ Chí Minh  
(72) Võ Trọng Lĩnh (VN)  
(55)



1.1

1.2

1.3

1.4

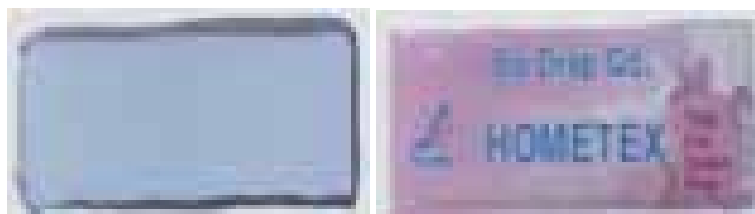

1.5

1.6

- (11) **13335**  
(21) 3-2008-00765 (28) 01  
(54) **VÒI NƯỚC** (51) **23-01**  
(22) 09.06.2008 (43) 25.08.2008  
(71) WATERTEC (MALAYSIA) SDN BHD (MY)  
Lot 6 Jalan Halba 16/16, Section 16, 40200 Shah Alam, Selangor, Malaysia  
(72) Maslinisak Bin Mohd Ramli (MY)  
(74) Công ty TNHH Tư vấn Phạm Anh Nguyên (ANPHAMCO CO.,LTD.)  
(55)



1.1



1.2



1.3



1.4

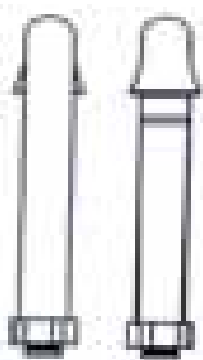

1.5

1.6



1.7



1.8

- (11) **13336**  
(21) 3-2008-00766 (28) 02  
(54) NHÃN SẢN PHẨM (51) **19-08**  
(22) 09.06.2008 (43) 25.08.2008  
(71) CÔNG TY CỔ PHẦN CHẾ BIẾN THỰC PHẨM HỮU NGHỊ (VN)  
Thạch Cầu, phường Long Biên, quận Long Biên, thành phố Hà Nội  
(72) Đỗ Huy Toàn (VN)  
(74) Công ty TNHH Sở hữu trí tuệ Thảo Thọ Quyến (INVENCO)  
(55)



1.1



1.2



2.1



2.2

- (11) **13337**  
(21) 3-2008-00767 (28) 01  
(54) BAO GÓI SẢN PHẨM (51) **19-08**  
(22) 09.06.2008 (43) 25.08.2008  
(71) CÔNG TY CỔ PHẦN THƯƠNG MẠI HÙNG NGỌC (VN)  
Thôn Kim Sơn, xã Lê Thiện, huyện An Dương, thành phố Hải Phòng  
(72) Nguyễn Mạnh Hùng (VN)  
(74) Công ty TNHH Nghiên cứu và Tư vấn chuyển giao công nghệ và đầu tư (CONCETTI)  
(55)



1.1



1.2

- (11) **13338**  
(21) 3-2008-00768 (28) 01  
(54) NHÃN SẢN PHẨM (51) **19-08**  
(22) 10.06.2008 (43) 25.08.2008  
(71) SIU GUAN CHEMICAL INDUSTRIAL CO., LTD. (TW)  
No. 128, Shin Min Road, Hunci Li, Chiayi, Taiwan  
(72) Pei Shi Tsai (TW)  
(74) Công ty TNHH Sở hữu trí tuệ WINCO (WINCO CO., LTD.)  
(55)

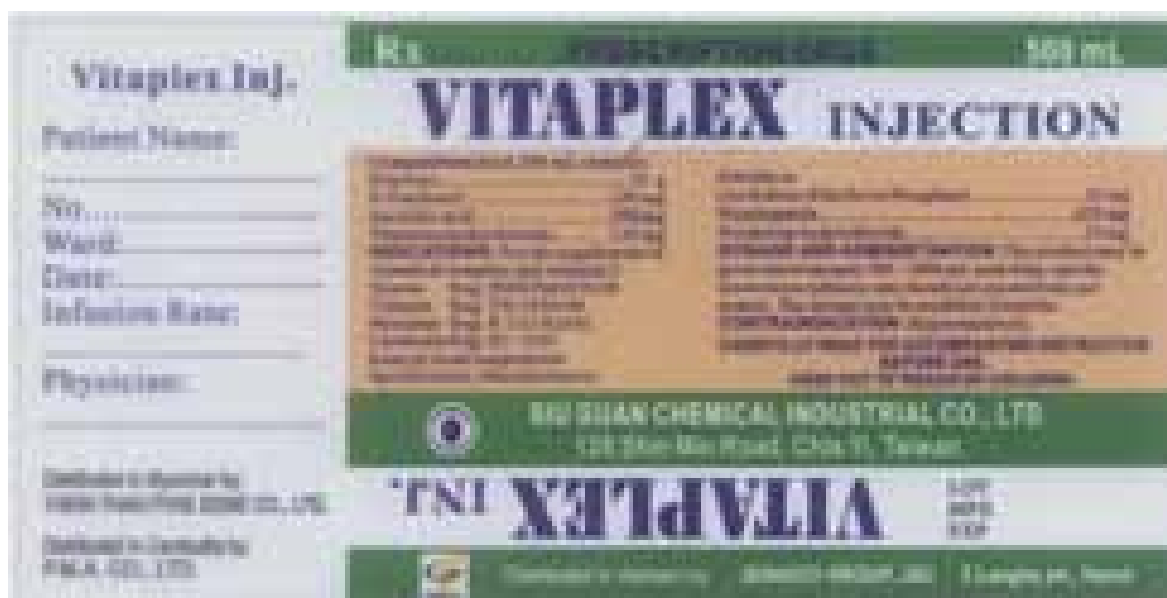

- (11) **13339**  
(21) 3-2008-00770 (28) 01  
(54) GHẾ (51) **06-01**  
(22) 12.06.2008 (43) 25.08.2008  
(71) DEDON GMBH (DE)  
Zeppelinstrasse 22, 21337 Luneburg, Germany  
(72) Massaud, Jean - Marie (FR)  
(74) Văn phòng Luật sư A Hoà (AHOA LAW OFFICE)  
(55)



1.1

1.2

1.3



1.4

1.5

1.6



- (11) **13340**  
(21) 3-2008-00771 (28) 01  
(54) GHẾ (51) **06-01**  
(22) 12.06.2008 (43) 25.08.2008  
(71) DEDON GMBH (DE)  
Zeppelinstrasse 22, 21337 Luneburg, Germany  
(72) Massaud, Jean - Marie (FR)  
(74) Văn phòng Luật sư A Hoà (AHOA LAW OFFICE)  
(55)



1.1

1.2

1.3



1.4

1.5

1.6

- (11) **13341**  
(21) 3-2008-00773  
(54) GHẾ  
(22) 12.06.2008  
(71) DEDON GMBH (DE)  
Zeppelinstrasse 22, 21337 Luneburg, Germany  
(72) Massaud, Jean - Marie (FR)  
(74) Văn phòng Luật sư A Hoà (AHOA LAW OFFICE)  
(55)
- (28) 01  
(51) **06-01**  
(43) 25.08.2008



1.1



1.2



1.3



1.4



1.5



1.6

- (11) **13342**  
(21) 3-2008-00775 (28) 01  
(54) GHẾ (51) **06-01**  
(22) 12.06.2008 (43) 25.08.2008  
(71) DEDON GMBH (DE)  
Zeppelinstrasse 22, 21337 Luneburg, Germany  
(72) Massaud, Jean - Marie (FR)  
(74) Văn phòng Luật sư A Hoà (AHOA LAW OFFICE)  
(55)



1.1

1.2

1.3



1.4

1.5

1.6

- (11) **13343**  
(21) 3-2008-00777 (28) 01  
(54) GHẾ (51) **06-01**  
(22) 12.06.2008 (43) 25.08.2008  
(71) DEDON GMBH (DE)  
Zeppelinstrasse 22, 21337 Luneburg, Germany  
(72) Mag. Art. Bergmann, Martin (AT), Mag. Art. Bohmann, Gernot (AT)  
(74) Văn phòng Luật sư A Hoà (AHOA LAW OFFICE)  
(55)



1.1

1.2

1.3



1.4

1.5

1.6

- (11) **13344**  
(21) 3-2008-00781 (28) 01  
(54) GHẾ (51) **06-01**  
(22) 12.06.2008 (43) 25.08.2008  
(71) DEDON GMBH (DE)  
Zeppelinstrasse 22, 21337 Luneburg, Germany  
(72) Mag. Art. Bergmann, Martin (AT), Mag. Art. Bohmann, Gernot (AT)  
(74) Văn phòng Luật sư A Hoà (AHOA LAW OFFICE)  
(55)



1.1

1.2

1.3



1.4

1.5

1.6

- (11) **13345**  
(21) 3-2008-00784 (28) 01  
(54) BAO GÓI KẸO (51) **09-05**  
(22) 13.06.2008 (43) 25.08.2008  
(71) CÔNG TY TNHH THƯƠNG MẠI VÀ SẢN XUẤT HÀ THÀNH (VN)  
77 Trường Lâm, quận Long Biên, thành phố Hà Nội  
(72) Phi Thị Thu Hà (VN)  
(55)



1.1



1.2

- (11) **13346**  
(21) 3-2008-00803 (28) 01  
(54) NẮP BÌNH (51) **09-07**  
(22) 16.06.2008 (43) 25.08.2008  
(71) CÔNG TY TRÁCH NHIỆM HỮU HẠN NHỰA CƠ KHÍ VÀ THƯƠNG MẠI CHẤN  
THỤẬN THÀNH (VN)  
93A Lý Chiêu Hoàng, phường 10, quận 6, TP. Hồ Chí Minh  
(72) Trần Em (VN)  
(74) Công ty TNHH Sở hữu trí tuệ Thảo Thọ Quyến (INVENCO)  
(55)

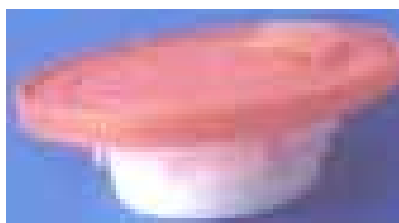

1.1

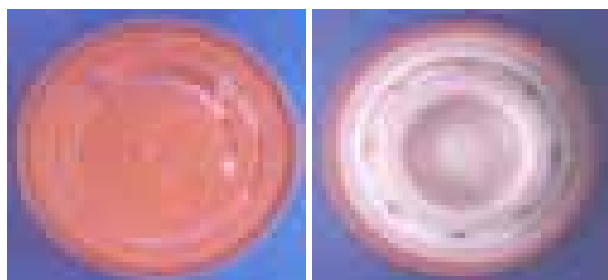

1.2

1.3

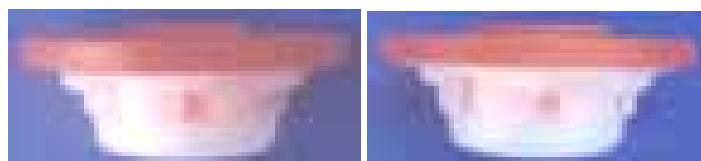

1.4

1.5



1.6

- (11) **13347**  
(21) 3-2008-00817 (28) 01  
(54) NHÃN SẢN PHẨM (51) **19-08**  
(22) 19.06.2008 (43) 25.08.2008  
(71) NGÂN HÀNG THƯƠNG MẠI CỔ PHẦN QUỐC TẾ VIỆT NAM (VIB BANK) (VN)  
64-68 Lý Thường Kiệt, quận Hoàn Kiếm, thành phố Hà Nội  
(72) Nguyễn Văn Tùng (VN)  
(74) Văn phòng luật sư Phạm và Liên danh (PHAM & ASSOCIATES)  
(55)





- (11) **13348**  
(21) 3-2008-00818 (28) 01  
(54) NHÃN SẢN PHẨM (51) **19-08**  
(22) 19.06.2008 (43) 25.08.2008  
(71) NGÂN HÀNG THƯƠNG MẠI CỔ PHẦN QUỐC TẾ VIỆT NAM (VIB BANK) (VN)  
64-68 Lý Thường Kiệt, quận Hoàn Kiếm, thành phố Hà Nội  
(72) Nguyễn Văn Tùng (VN)  
(74) Văn phòng luật sư Phạm và Liên danh (PHAM & ASSOCIATES)  
(55)



- (11) **13349**  
(21) 3-2008-00819 (28) 01  
(54) NHÃN SẢN PHẨM (51) **19-08**  
(22) 19.06.2008 (43) 25.08.2008  
(71) NGÂN HÀNG THƯƠNG MẠI CỔ PHẦN QUỐC TẾ VIỆT NAM (VIB BANK) (VN)  
64-68 Lý Thường Kiệt, quận Hoàn Kiếm, thành phố Hà Nội  
(72) Nguyễn Văn Tùng (VN)  
(74) Văn phòng luật sư Phạm và Liên danh (PHAM & ASSOCIATES)  
(55)



- (11) **13350**  
(21) 3-2008-00821 (28) 01  
(54) NHÃN SẢN PHẨM (51) **19-08**  
(22) 19.06.2008 (43) 25.08.2008  
(71) CÔNG TY TNHH TRUNG THU (VN)  
Số 46E khu 8, Thị Cầu, thành phố Bắc Ninh, tỉnh Bắc Ninh  
(72) Nguyễn Trung Kiên (VN)  
(74) Công ty TNHH Sở hữu trí tuệ Gia Việt (GIAVIET CO., LTD.)  
(55)

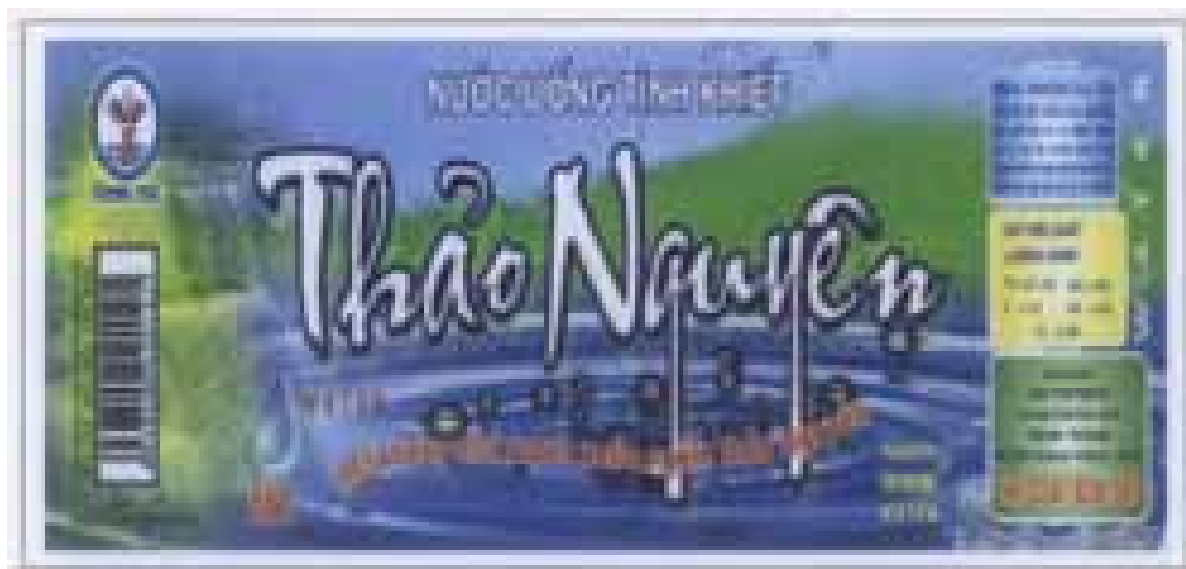

- (11) **13351**  
(21) 3-2008-00822 (28) 02  
(54) GHẾ (51) **06-01**  
(22) 19.06.2008 (43) 25.08.2008  
(71) CÔNG TY CỔ PHẦN CAO SU SÀI GÒN - KYMDAN (VN)  
28 Bình Thới, phường 14, quận 11, TP. Hồ Chí Minh  
(72) Nguyễn Hữu Trí (VN)  
(74) Công ty TNHH Sở hữu trí tuệ Thảo Thọ Quyển (INVENCO)  
(55)



1.1



1.2



1.3



1.4

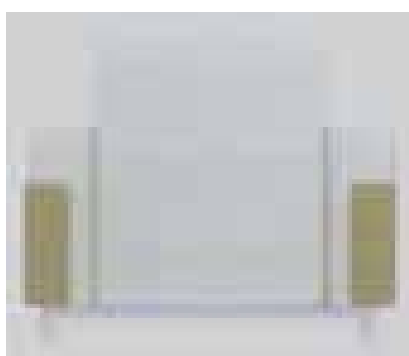

1.5

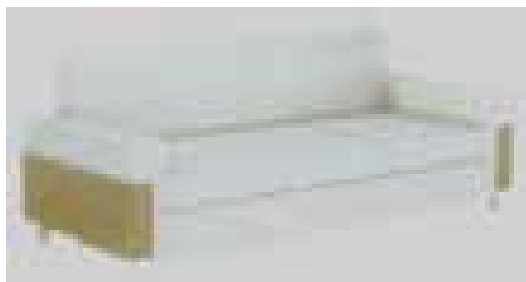

2.1

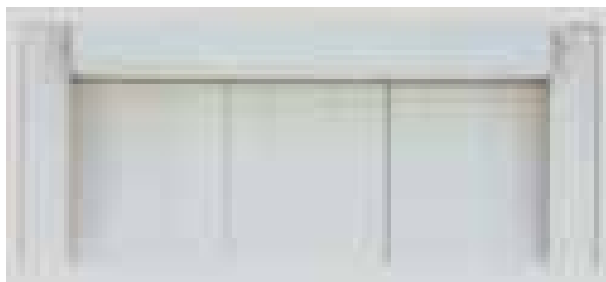

2.2

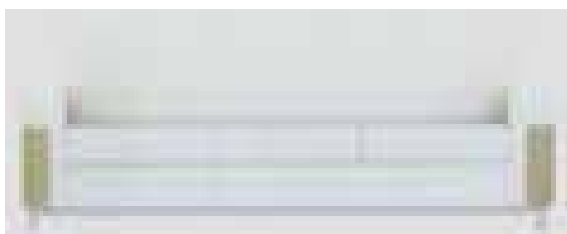

2.3



2.4



2.5

- (11) **13352**  
(21) 3-2008-00823 (28) 01  
(54) TỦ (51) **06-04**  
(22) 19.06.2008 (43) 25.08.2008  
(71) CÔNG TY CỔ PHẦN CAO SU SÀI GÒN - KYMDAN (VN)  
28 Bình Thới, phường 14, quận 11, TP. Hồ Chí Minh  
(72) Nguyễn Hữu Trí (VN)  
(74) Công ty TNHH Sở hữu trí tuệ Thảo Thọ Quyến (INVENCO)  
(55)



1.1

1.2

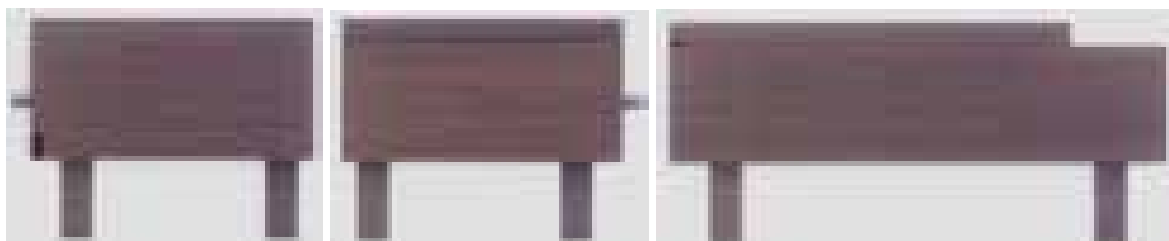

1.3

1.4

1.5

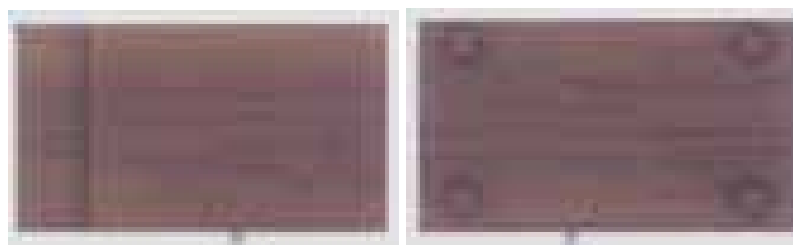

1.6

1.7

- (11) **13353**  
(21) 3-2008-00824 (28) 01  
(54) GIƯỜNG NGỦ (51) **06-02**  
(22) 19.06.2008 (43) 25.08.2008  
(71) CÔNG TY CỔ PHẦN CAO SU SÀI GÒN - KYMDAN (VN)  
28 Bình Thới, phường 14, quận 11, TP. Hồ Chí Minh  
(72) Nguyễn Hữu Trí (VN)  
(74) Công ty TNHH Sở hữu trí tuệ Thảo Thọ Quyến (INVENCO)  
(55)



1.1



1.2



1.3

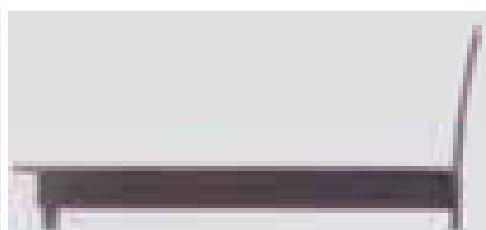

1.4

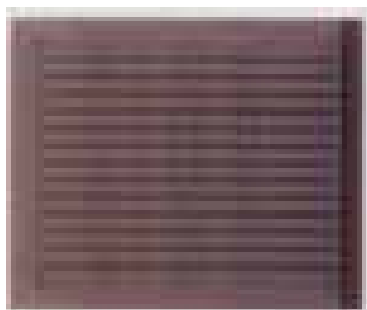

1.5

- (11) **13354**  
(21) 3-2008-00829 (28) 01  
(54) KHUNG MẮC VÕNG (51) **06-02**  
(22) 19.06.2008 (43) 25.08.2008  
(71) CÔNG TY CỔ PHẦN DUY HUYỀN (VN)  
1007A Thoại Ngọc Hầu, phường Hoà Thạnh, quận Tân Phú, TP. Hồ Chí Minh  
(72) Huỳnh Quang Đạo (VN)  
(74) DNTN Dịch vụ thương mại và sở hữu công nghiệp Song Ngọc (I.P.T.S.)  
(55)



1.1

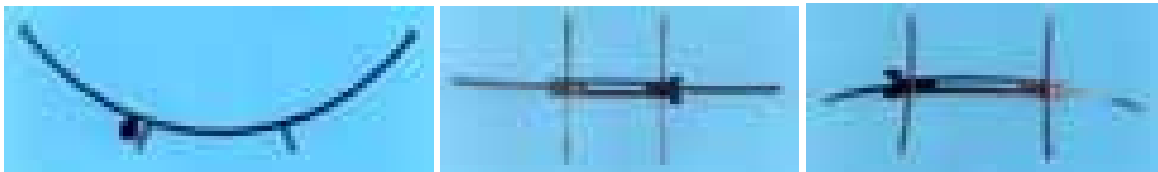

1.2

1.3

1.4

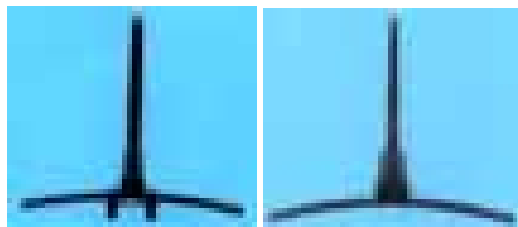

1.5

1.6



- (11) **13355**  
(21) 3-2008-00830 (28) 01  
(54) **ĐẾ VÁN LÁT SÀN** (51) **25-01**  
(22) 19.06.2008 (43) 25.08.2008  
(71) **CÔNG TY CỔ PHẦN DUY HUYỀN (VN)**  
1007A Thoại Ngọc Hầu, phường Hoà Thạnh, quận Tân Phú, TP. Hồ Chí Minh  
(72) Huỳnh Quang Đạo (VN)  
(74) DNTN Dịch vụ thương mại và sở hữu công nghiệp Song Ngọc (I.P.T.S.)  
(55)



1.1

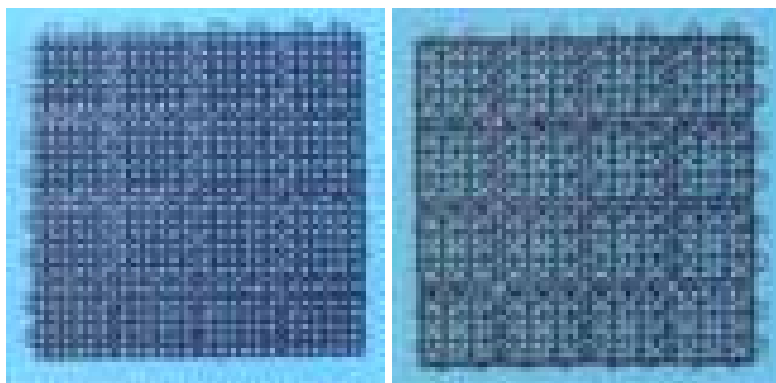

1.2

1.3



1.4

1.5

- (11) **13356**  
(21) 3-2008-00831 (28) 01  
(54) KHUNG MẮC VÕNG (51) **06-02**  
(22) 19.06.2008 (43) 25.08.2008  
(71) CÔNG TY CỔ PHẦN DUY HUYỀN (VN)  
1007A Thoại Ngọc Hầu, phường Hoà Thạnh, quận Tân Phú, TP. Hồ Chí Minh  
(72) Huỳnh Quang Đạo (VN)  
(74) DNTN Dịch vụ thương mại và sở hữu công nghiệp Song Ngọc (I.P.T.S.)  
(55)



1.1

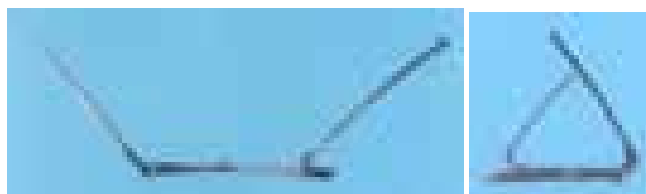

1.2

1.3



1.4

1.5

- (11) **13357**  
(21) 3-2008-00834 (28) 01  
(54) HỘ ĐUNG THUỐC (51) **09-03**  
(22) 20.06.2008 (43) 25.08.2008  
(71) CÔNG TY CỔ PHẦN THƯƠNG MẠI VÀ DƯỢC PHẨM NGỌC THIÊN (VN)  
Số 10, ngõ 3, đường Lý Bôn, thành phố Vinh Yên, tỉnh Vĩnh Phúc  
(72) Nguyễn Thế Quyền (VN)  
(74) Công ty TNHH Vĩnh Đạt (LACOM CO., LTD.)  
(55)



1.1



1.2

- (11) **13358**  
(21) 3-2008-00842 (28) 03  
(54) BAO ĐỰNG PHÂN BÓN (51) **09-05**  
(22) 24.06.2008 (43) 25.08.2008  
(71) CÔNG TY TNHH SITTO VIỆT NAM (VN)  
Số 4, đường 3A, khu công nghiệp Biên Hoà II, tỉnh Đồng Nai  
(72) Theerapong Ritmak (TH)  
(74) Công ty Cổ phần Sở hữu công nghiệp INVESTIP (INVESTIP)  
(55)



1.1



1.2



2.1



2.2



3.1



3.2

- (11) **13359**  
(21) 3-2008-00845  
(54) NHÃN SẢN PHẨM  
(22) 25.06.2008  
(71) LÊ CƯỜNG (VN)  
378/11 Xô Viết Nghệ Tĩnh, phường 25, quận Bình Thạnh, TP. Hồ Chí Minh  
(72) Lê Cường (VN)  
(55)  
(28) 01  
(51) **19-08**  
(43) 25.08.2008



- (11) **13360**  
(21) 3-2008-00847 (28) 01  
(54) NHÃN SẢN PHẨM (51) **19-08**  
(22) 25.06.2008 (43) 25.08.2008  
(71) CÔNG TY VACXIN VÀ SINH PHẨM SỐ 2 (VN)  
26 Hàn Thuyên, thành phố Nha Trang, tỉnh Khánh Hòa  
(72) Cao Quang Minh (VN)  
(74) Công ty TNHH Sở hữu trí tuệ WINCO (WINCO CO., LTD.)  
(55)



- (11) **13361**  
(21) 3-2008-00850 (28) 01  
(54) HỘP (51) **09-03**  
(22) 26.06.2008 (43) 25.08.2008  
(71) DOANH NGHIỆP TƯ NHÂN ĐỨC VĨNH (VN)  
61/42 Mã Lò, khu phố 1, phường Bình Trị Đông A, quận Bình Tân, TP. Hồ Chí Minh  
(72) Lục Quế Đức (VN)  
(74) Văn phòng luật sư Phạm và Liên danh (PHAM & ASSOCIATES)  
(55)



1.1



1.2



- (11) **13362**  
(21) 3-2008-00853 (28) 01  
(54) BAO GÓI ĐỰNG GIẤY (51) **09-05**  
(22) 30.06.2008 (43) 25.08.2008  
(71) CÔNG TY TNHH ĐÔNG HIỆP (VN)  
Lô CN7, cụm công nghiệp tập trung vừa và nhỏ Từ Liêm, xã Minh Khai, huyện Từ  
Liêm, thành phố Hà Nội  
(72) Nguyễn Thị Thủy Lệ (VN)  
(55)



1.1



1.2



1.3



1.4

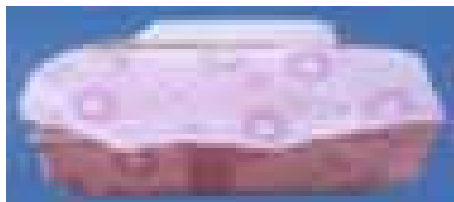

1.5

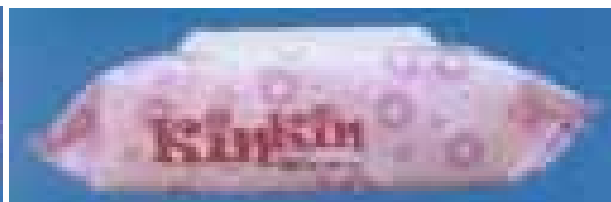

1.6

- (11) **13363**  
(21) 3-2008-00857 (28) 01  
(54) NHÃN SẢN PHẨM (51) **19-08**  
(22) 30.06.2008 (43) 25.08.2008  
(71) BỒ VĂN CƯỜNG (VN)  
295/14/6 Kinh Dương Vương, phường An Lạc, quận Bình Tân, TP. Hồ Chí Minh  
(72) Bồ Văn Cường (VN)  
(74) Công ty TNHH Sở hữu trí tuệ Thảo Thọ Quyến (INVENCO)  
(55)



1.1



1.2

- (11) **13364**  
(21) 3-2008-00858 (28) 01  
(54) NHÃN SẢN PHẨM (51) **19-08**  
(22) 30.06.2008 (43) 25.08.2008  
(71) BỒ VĂN CƯỜNG (VN)  
295/14/6 Kinh Dương Vương, phường An Lạc, quận Bình Tân, TP. Hồ Chí Minh  
(72) Bồ Văn Cường (VN)  
(74) Công ty TNHH Sở hữu trí tuệ Thảo Thọ Quyến (INVENCO)  
(55)

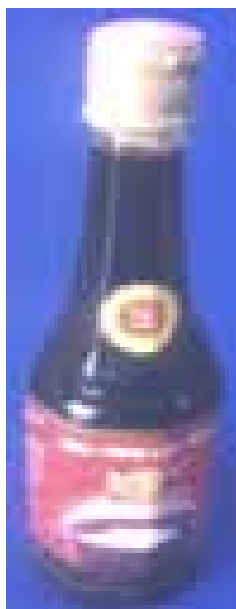

1.1

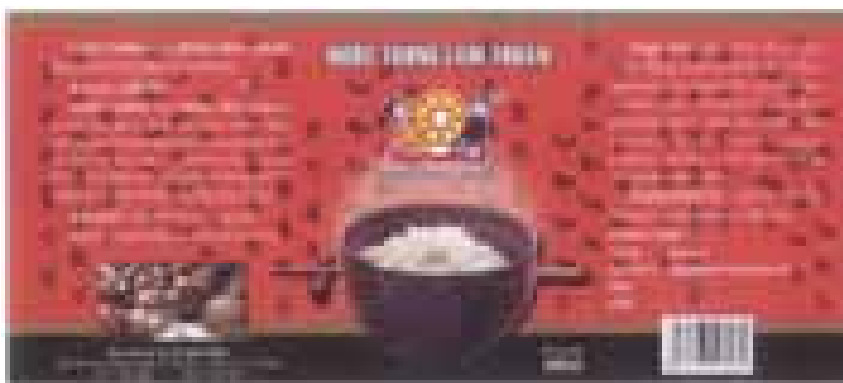

1.2